

# JUNG STAY



Hospitality Solutions EN



Ernst Paris

Company founder  
Albrecht Jung

# Progress as tradition.

JUNG stands for pure design and future-oriented solutions worldwide. Innovation, passion and precision have been guiding our product developments for more than 100 years. Light, shading, air conditioning, energy, security, door communication and multimedia – our systems provide the appropriate solution for every requirement.

We are present on 5 continents in around 70 countries with 19 subsidiaries and 1,300 employees and independent sales and partner organisations. Whether private, commercial or hotel construction: Architects and planners worldwide place their trust in the innovative solutions from JUNG. Our building technology can be found in the Reichstag in Berlin as well as in the Hermitage in St. Petersburg or the Shangri-La Hotel in Singapore.

We consciously combine this internationality with close ties to the headquarters of our family business in Schalksmühle. We develop and manufacture components for classic electrical installations as well as intelligent systems for building technology there and in Lünen. Flow production, small series or manufacture: Our modern production methods meet the highest requirements.

## WE ARE JUNG:

1912

Medium-sized third generation family company



"Made in Germany" for more than 100 years



Around 1300 employees



19 subsidiaries and over 70 agencies worldwide



# Foreword

For more than 100 years, the name JUNG has stood for components and systems that are impressive due to modern technology, sophisticated design and wide functional diversity. With the JUNG Hospitality Solutions, there are many possibilities to increase the efficiency for the owner, to increase the comfort for the guest and to optimise the work processes for the personnel. A comprehensive range of products that can be individually combined according to a modular system enables hotels to be built to the latest standards or historic buildings to be modernised with the latest technical possibilities.

JUNG manufactures its products in Germany. The company manufactures high-quality products that worldwide customers rely on at the Schalksmühle and Lünen sites.

<b>FOREWORD</b>	<b>4</b>	3.1.1 Button assignment possibilities in KNX F 10	74
<b>1. KEY CHARACTERISTICS AND ADVANTAGES</b>	<b>10</b>	3.1.2 Button assignment possibilities in KNX F 40	75
1.1 Customer benefits from JUNG	12	3.1.3 Button assignment possibilities in KNX F 50	76
1.1.1 Simple and flexible installation	13	3.2 Visu Pro Hotel software	77
1.1.2 Clear advantages	14	3.2.1 Reception	78
1.2 Design	15	3.2.2 Housekeeping	79
1.2.1 Colours and materials	15	3.3 Interfaces and network	81
1.2.2 Individualism	19	3.3.1 KNX	81
1.2.3 Sustainability	20	3.3.2 WLAN	82
1.3 Internationality	21	<b>4. INTERNATIONAL SOCKETS</b>	<b>84</b>
1.3.1 G + I socket	22	4.1 Fused Cable Unit	87
1.3.2 Installation of electric shaver socket outlet	23	4.2 Overview of international sockets	88
1.3.3 Surface-mounted installations	24	<b>5. CARD READER</b>	<b>96</b>
1.4 Comfort for the guest	25	5.1 Covers	98
1.4.1 Intuitive operation	25	5.2 Installation	99
1.4.2 All-round carefree comfort	26	<b>6. HOUSEKEEPING</b>	<b>100</b>
1.4.3 Full power – sockets with USB port	27	6.1 Overview of corridor units	103
1.5 Usefulness for the owner	28	6.2 Corridor Units	104
1.5.1 Efficient operations	28	6.2.1 Inserts	104
1.5.2 Smart solutions for the hotel	29	6.2.2 Lighting	106
<b>2. APPLICATION EXAMPLES</b>	<b>30</b>	6.2.3 Attachments	107
2.1 Hotel room	32	6.3 Overview of room units	111
2.1.1 Economy	34	6.4 Room Units	112
2.1.2 Mid-scale	42	6.4.1 Inserts	112
2.1.3 Luxury A	50	6.4.2 Colour change	113
2.1.4 Luxury B	60	6.4.3 Triple-tone door signal	114
<b>3. OPERATION</b>	<b>70</b>	6.4.4 Attachments	115
3.1 Operating philosophy for switching, sensing, dimming	72	6.4.5 Connection	117
		6.5 Visualisation via KNX	119

<b>7. KEY CARD HOLDER</b>	<b>120</b>	8.6 LED pilot light with traffic light function	151
7.1 Equipment Overview	123	8.6.1 Inserts	151
7.2 Mechanical key card holder	124	8.6.2 Attachments	151
7.2.1 Inserts	124	8.6.3 Connection	152
7.2.2 Lighting	126	8.7 LED reading light	153
7.2.3 Attachments	127	8.7.1 Inserts	153
7.2.4 Connection	128	8.7.2 Attachments	153
7.3 Electronic RFID key card holder	129	8.7.3 Connection	153
7.3.1 Inserts	130	8.8 LED pilot light RGB, blue, white	155
7.3.2 Attachments	131	8.8.1 Inserts	155
7.3.3 Accessories	133	8.8.2 Attachments	155
7.3.4 Key cards	133	8.8.3 Connection	155
7.3.5 Connection	134	8.9 Plug & Light as pilot lights	157
7.3.6 Key Card Configurator	135	8.10 LED glass cover	158
7.3.7 RFID key card holder with ASSA ABLOY	135	8.10.1 Insert	159
<b>8. ORIENTATION AND INFORMATION LIGHTING</b>	<b>136</b>	8.10.2 Attachments	160
8.1 SCHUKO® and glass cover overview	139	8.10.3 Connection	161
8.2 Overview of LED pilot lights	141	<b>9. AUTOMATIC LIGHT</b>	<b>162</b>
8.3 SCHUKO® socket with LED floor pilot light	142	9.1 Device Overview	165
8.3.1 Inserts	142	9.2 Operating modes and functions	166
8.3.2 Connection	143	9.3 Inserts	168
8.4 LED pilot light with integrated brightness sensor	144	9.3.1 Switch inserts	168
8.4.1 Inserts	144	9.3.2 Installation and electrical connection	170
8.4.2 Connection	146	9.3.3 Dimming inserts	172
8.5 LED info sign	147	9.3.4 Installation and electrical connection	173
8.5.1 Inserts	147	9.3.5 Expansion inserts	174
8.5.2 Attachments	148	9.3.6 Installation and electrical connection	176
8.5.3 Connection	149		

9.4	Attachments	179	9.7.9	Installation and electrical connection of KNX automatic switch 2.2 m	208
9.4.1	Standard automatic switch 1.1 m	179	9.7.10	KNX ceiling observer / presence detector	209
9.4.2	Standard automatic switch 2.2 m	180	9.7.11	Installation and electrical connection of KNX presence detector mini and KNX brightness controller mini	211
9.4.3	Installation and electrical connection of the Standard automatic switches 1.1 m and 2.2 m	181	9.7.12	Installation and electrical connection of KNX presence detector / ceiling observer	213
9.4.4	Universal automatic switch 1.1 m	182	9.8	Motion detector Mini Basic	214
9.4.5	Universal automatic switch 2.2 m	183	9.8.1	Use Case I – Guest room	214
9.4.6	Installation and electrical connection of the Universal automatic switches 1.1 m and 2.2 m	184	9.8.2	Use Case 2 – Presence monitoring with motion detector – Luxury hotel room	216
9.4.7	Mini Basic ceiling observer / presence detector / motion detector	186	<b>10. HEATING AND COOLING</b>	<b>218</b>	
9.4.8	Installation and electrical connection of ceiling observer / presence detector	187	10.1	Equipment Overview	221
9.5	Setting up detection fields	192	10.1.1	Connection and functions	222
9.5.1	Adjustment of the parameters for automatic switches / ceiling observers / presence detectors	196	10.2	2-pipe and 4-pipe systems	224
9.6	Accessories	197	10.2.1	Connecting 2-pipe fan coil unit	224
9.7	KNX automatic switches and presence detectors	198	10.2.2	Connecting 4-pipe fan coil unit	225
9.7.1	Device Overview	199	10.3	Operating modes and profiles	226
9.7.2	KNX bus coupling unit insert	200	10.4	KNX	228
9.7.3	Installation and electrical connection of KNX bus coupling unit 3	201	<b>11. INNOVATION: PLUG + GO</b>	<b>230</b>	
9.7.4	KNX automatic switch 1.1 m Standard	202	11.1	plug + go: the ready to plug-in electrical installation	232
9.7.5	KNX automatic switch 1.1 m Universal	203	11.1.1	Individual configurations	233
9.7.6	Installation and electrical connection of KNX automatic switch 1.1 m	204	11.1.2	The potential savings	235
9.7.7	KNX automatic switch 2.2 m Standard	206	11.1.3	Use in the hotel sector	237
9.7.8	KNX automatic switch 2.2 m Universal	207	<b>12. INNOVATION: PLUG &amp; LIGHT</b>	<b>238</b>	
			12.1	Plug & Light: the functionally reliable lighting design	240
			12.1.1	Rethinking light	241
			12.1.2	Advantages of Plug & Light	241



12.1.3 Plug-in lighting moods	242	<b>14. KNX SCENARIOS</b>	<b>272</b>
12.1.4 The light socket	244	14.1 Smart building technology with KNX	276
12.1.5 The LED spotlights	246	14.2 Core KNX components	278
12.1.6 The LED floodlights	248	14.3 The KNX-controlled hotel room	280
12.1.7 The range of frames	250	14.4 KNX Secure	281
<b>13. DOOR COMMUNICATION AND ACCESS CONTROL</b>	<b>254</b>	14.5 Application: New construction of a family-run hotel	282
13.1 Device Overview	257	14.5.1 Objective of the project	283
13.2 Door communication	258	14.5.2 Steps in the Engineering Tool software	283
13.2.1 Diversity of design in door communication	259	14.5.3 Additional note	283
13.2.2 Video indoor stations	259	14.6 Application: New construction of a smart hotel	284
13.2.3 Audio indoor station	262	14.6.1 Objective of the project	285
13.2.4 Connection of video and audio indoor unit	264	14.6.2 Steps in the Engineering Tool software	285
13.2.5 Standard audio indoor station and standard design	265	14.6.3 Additional notes	285
13.2.6 Connection of standard and universal audio indoor unit	267	14.7 JUNG Visu Pro – the link	286
13.3 Door communication and KNX	268	14.8 JUNG Visu Pro – The System Overview	288
13.4 Oversize rocker	269	14.9 JUNG Visu Pro – Applications	290
13.4.1 Installation special features	270	14.9.1 ECONOMY	290
13.4.2 Installation	270	14.9.2 MID-SCALE	293
		14.9.3 LUXURY	296





## 1. KEY CHARACTERISTICS AND ADVANTAGES

### 1.1 CUSTOMER BENEFITS FROM JUNG 12

1.1.1 Simple and flexible installation 13

1.1.2 Clear advantages 14

### 1.2 DESIGN 15

1.2.1 Colours and materials 15

1.2.2 Individualism 19

1.2.3 Sustainability 20

### 1.3 INTERNATIONALITY 21

1.3.1 G + I socket 22

1.3.2 Installation of electric shaver  
socket outlet 23

1.3.3 Surface-mounted installations 24

### 1.4 COMFORT FOR THE GUEST 25

1.4.1 Intuitive operation 25

1.4.2 All-round carefree comfort 26

1.4.3 Full power – sockets with USB port 27

### 1.5 USEFULNESS FOR THE OWNER 28

1.5.1 Efficient operations 28

1.5.2 Smart solutions for the hotel 29

# 1. Key characteristics and advantages

Modern technical equipment is indispensable for a comfortable hotel. It enables the reconciliation of emotional, economic and ecological aspects.

The design language of the JUNG components tastefully blends into the architectural design of the hotel for this. Whether in new buildings or in the modernisation of existing buildings.

## 1.1 Customer benefits from JUNG

Simple and quick installation of the individual components not only saves time, but also money. For this reason, JUNG places particular emphasis on the easy installation of its components. The low installation depth of the inserts provides more space for the wiring. Support plates made of galvanised steel provide sufficient stability. Enclosed mounting claws allow quick installation and provide a secure hold in flush-mounted and cavity boxes. Almost all technical requirements can also be realised as stylish surface-mounted variants - a great advantage when modernising historic existing buildings, where chisel work is not always possible or desirable.

### 1.1.1 Simple and flexible installation

Planners and developers of international hotel projects have to react to different structural conditions. Therefore, for example, the JUNG sockets can also be integrated into the installation components for British sockets.

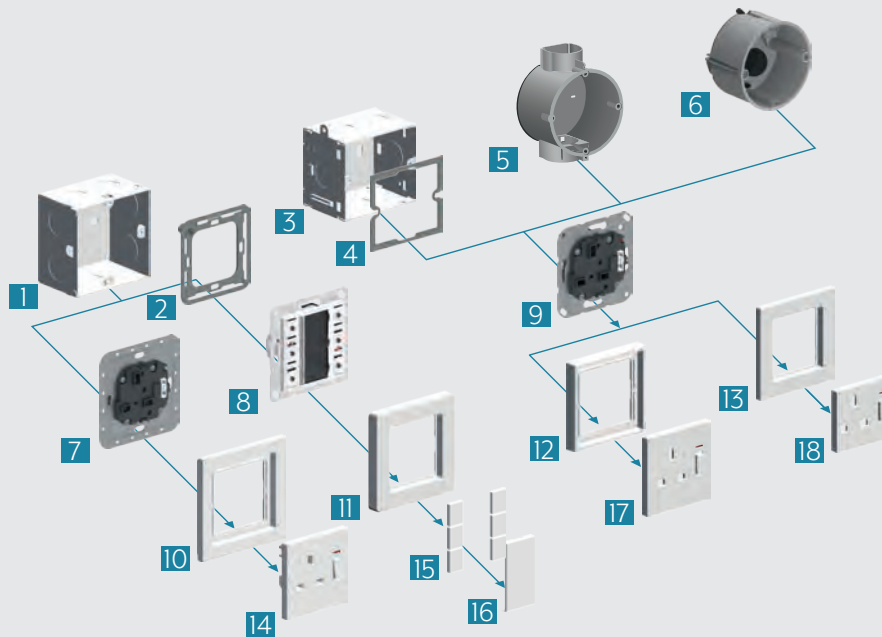

- 1 Wall box according to standard BS 4662
- 2 Adapter frame BS1980APM
- 3 Wall box BS 6042 M
- 4 Plaster levelling frame PCF6042
- 5 Wall box for masonry according to DIN 49073
- 6 Wall box for cavity wall installation according to DIN 49073
- 7 Insert with supporting ring 82 mm (e.g. BS 2171 KO EINS)
- 8 KNX push-button module Standard, 3-gang, A5073TSM
- 9 Insert with supporting ring 71x71 mm (e.g. BS 3171 KO EINS)
- 10 Frame BS 2181 WW (for all devices with supporting ring 82x82, such as insert BS 2171 KO EINS)
- 11 Frame A FLOW or A550, e.g. B. A FLOW (AF 581 BF WW)
- 12 Frames in the LS range (for all devices with JUNG standard supporting ring 71x71 mm, e.g. 3171 KO EINS)
- 13 Frames in the A range (for all devices with JUNG standard supporting ring 71x71 mm, e.g. 3171 KO EINS)
- 14 Centre plate BS 2171 KO WW PL (suitable for insert BS 2171 KO EINS)
- 15 F50 cover kit, 3-gang, A503TSAWW
- 16 Labelling field
- 17 Centre plate BS 2171 KO WW PL (suitable for insert 3171 KO EINS and frames LS, LS-DESIGN, LS PLUS etc.)
- 18 Centre plate A 3171 KO WW PL (suitable for insert 3171 KO EINS and frames in the A range)

### 1.1.2 Clear advantages

With their well thought-out components, the JUNG Hospitality Solutions enable a coherent technology concept for the modern hotel.

#### **PLANNER/OWNER**

---

Simple and economical installations due to shortened installation times

---

Worldwide applications due to internationally approved products

---

Can be used for new buildings as well as for renovations with surface-mounted and flush-mounted solutions

---

Colour and material of the attachments can be selected from the extensive JUNG range

---

All inserts can be freely combined with the JUNG attachments in the A, CD and LS design ranges

---

#### **GUEST**

---

Simple and intuitive operation for all age groups

---

Well thought-out connection options

---

Use of an all-round carefree package using programmed scenes

---

#### **OWNER**

---

JUNG Visu Pro software as centre for coordination of the housekeeping

---

Room conditions are displayed on centrally mounted panels

---

Housekeeping tasks are displayed on smart phones and can be checked off that way

---

Sustainable hotel solutions, thereby reducing consumption costs

---

## 1.2 Design

### 1.2.1 Colours and materials

Free combination options with the frames and attachments from the JUNG A and LS design ranges always provide a stylish and tasteful appearance.



A 550 in white



A 550 in aluminium look



A CREATION in champagne



A FLOW in anthracite (matt)

#### Plastic\*

white	
black	
aluminium	
champagne	
mocha	
matt anthracite	
matt snow white	
matt graphite black	

#### Glass\*\*

black		champagne	
red		mocha	
blue-grey			
matt white			
white			
silver			

\* In addition to the listed colours, the frames and attachments are also available in many other colours. Further information can be found at [www.jung.de/en/](http://www.jung.de/en/)

\*\* Glass frame only available for A Creation

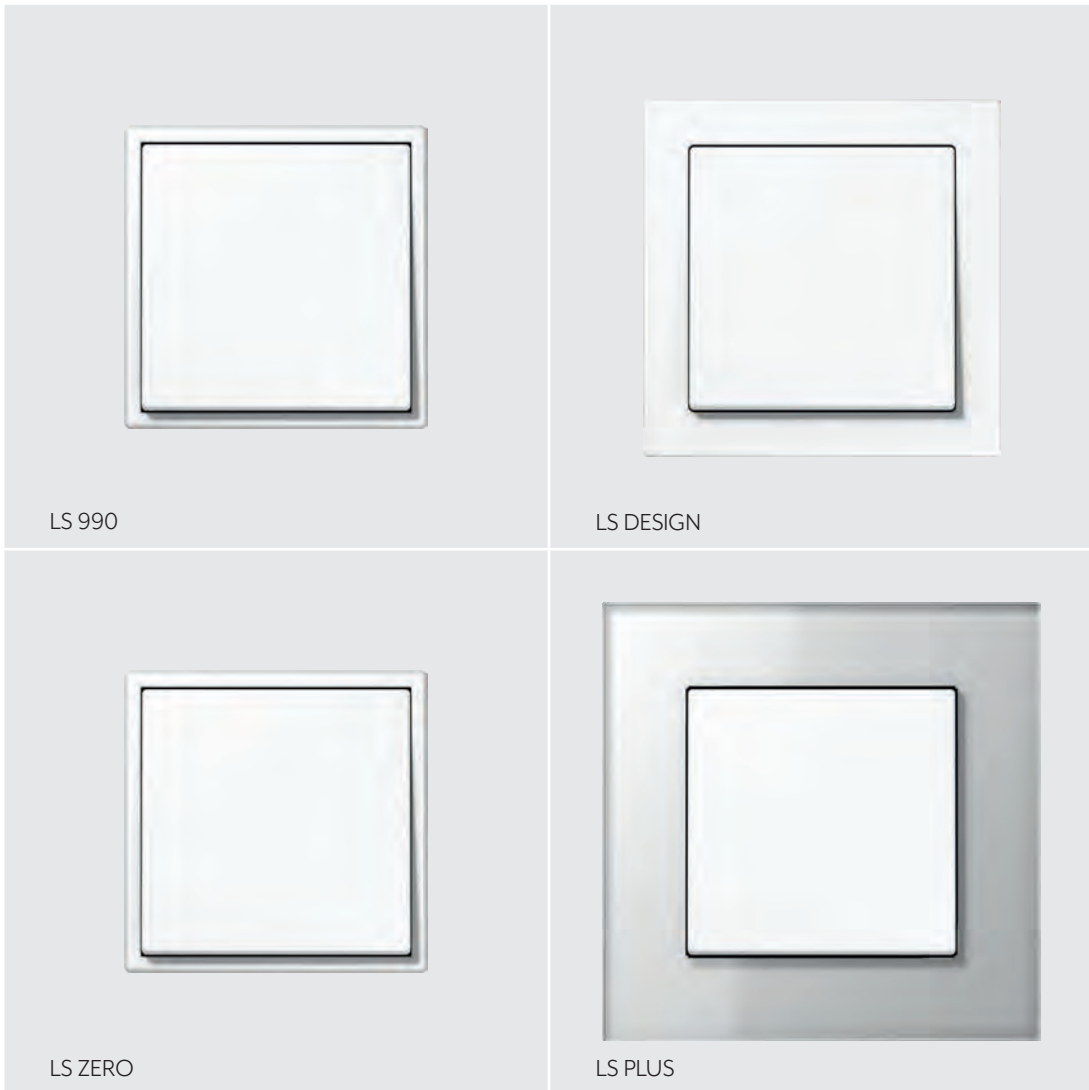

**Metal**

Aluminium		dark*		gold-plated	
Stainless steel		Chrome		Classic brass	
anthracite*		golden		Antique brass	

\* lacquered aluminium

**Plastic**

ivory		light grey	
white		black	
matt snow white		matt graphite black	

**Glass**

matt white	
white	
black	



## LS ZERO

In modern, purist interior design, flowing, even transitions between surfaces and building elements are becoming more and more prevalent. With the development of the LS ZERO design range, based on the LS 990 switch range, JUNG achieves the claim that the frame and switch literally immerse themselves in the wall.

JUNG developed a plastering adapter to ensure a flush transition from the frame to the wall. The material combination of ceramic and plastic provides all the connection characteristics for frames and device covers to integrate almost completely into the wall. Installation is possible in masonry, in dry wall construction and in furniture installation.



### Masonry mounting steps

1. Clearance for wall box, e.g. using drill bit. In doing so, take into account that the wall box should be plastered flush with the wall (otherwise plaster layer must be applied thicker by the amount of the protrusion).
2. Centre wall box on the wall.
3. Align plastering aid centrally using markings over the wall box and tack on the wall.
4. Apply plaster in the usual way and depending on requirements. The plastering aid specifies the plaster thickness.
5. After drying, remove the plastering aid and clean the space.
6. Now coat the plastering adapter on the rear side with plaster and bring into the space produced. Ensure that the recesses and screw holes of the plastering aid match those of the wall box. Now align the plastering adapter and make it flush with the finished plastered wall.
7. After drying, the remaining intermediate space is filled with plaster and excess plaster is removed. The plastering adapter is now flush in the wall.
8. After grinding the surface, the plastering adapter is embedded seamlessly in the plaster layer and is visually part of the wall. The inner edges of the plastering adapter form the finished termination for the LS ZERO design frame.
9. The electrical installation and the installation of the design covers are performed as usual.

### Dry wall mounting steps

1. Position and process the dry wall board in the usual way. A double board layer is required.
2. Clearance for wall box, e.g. using drill bit.
3. Centre wall box on the wall.
4. Align plastering aid centrally over the wall box using markings and mark all round to mark the size of the clearance.
5. Now cut around the marked area with a cutter and a bar and remove the first board layer.
6. Fasten wall box on the board layer below as usual.
7. Align plastering adapter in the clearance and fasten to the box using the box screws.
8. Now fill the remaining intermediate space with filler and remove excess filler.  
The plastering adapter is flush in the wall.
9. After grinding the surface, the plastering adapter is seamlessly embedded in the dry wall board. The inner edges of the plastering adapter form the finished termination for the LS ZERO design frame.
10. The electrical installation and the installation of the design covers are performed as usual.

### Furniture installation

For the furniture installation, the contour of the plastering adapter is applied in the respective part using a milling machine. The use of the plastering adapter is not necessary in this case. All required drawing data are available for download at [jung.de/lzero](http://jung.de/lzero). The mounting afterwards is performed as standard; in doing so, the LS ZERO design frame is directly in the clearance and forms a flush-mounted transition to the furniture.

**As an alternative to flush mounting (0 mm installation height), LS ZERO is also available in a version with 3 mm installation height. The design frame minimally overlaps the wallpaper edge on walls with wallpaper. This version is also suitable for plaster or plasterboard with a thickness of 12.5 mm.**

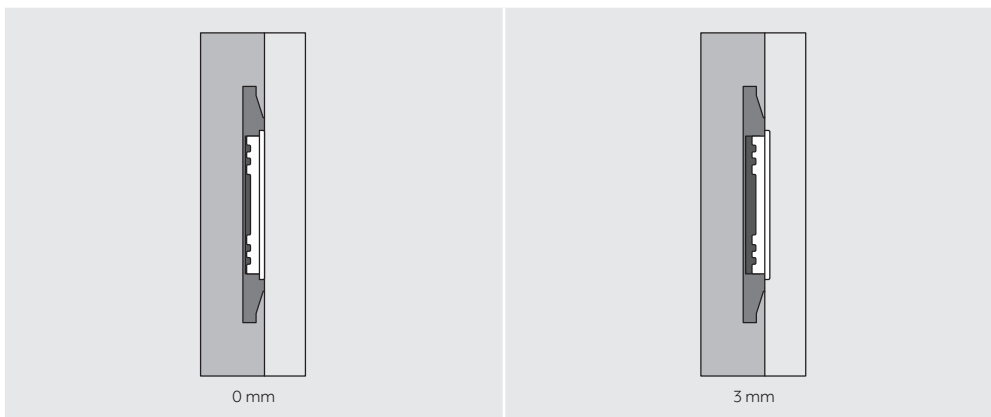

## 1.2.2 Individualism

### Individual design

The JUNG components can optionally also be labelled with the CI-compliant typography of the customer / hotel in addition to the common fonts (Arial, Times New Roman and JUNG Single Regular).

The customer transfers his desired typography in the form of jpg, png, bmp or svg files to the JUNG Graphic Tool (<https://www.jung.de/en/2292/service/graphic-tool/>).

### Laser engraving

Precise erosion of the surface for a particularly valued appearance: the finest contours of logos and texts can also be realised using laser engraving.

A striking form of product refinement, particularly for the metal versions.



### Laser engraving on glass

The high-quality **glass** hotel displays can also be inscribed using laser engraving. The coloured lighting of the displays completes the extraordinary appearance.

Labelling on the products: **L**



### Colour printing

Easily integrate the design of the electrical installation in the own corporate design – using abrasion-resistant colour printing. Symbols, individual texts and patterns also give the elements an unmistakable look.

Labelling on the products: **P**



### Labelling

Many Jung products have an integrated labelling field. These can be printed with text or symbols using the labelling in the pad printing process. The functions of switches, push-buttons and sockets are clearly identified.

Graphic Tool online: [jung.de/gt](http://jung.de/gt)



### 1.2.3 Sustainability

In the context of sustainability, the economical use of resources is essential. The focus here is on energy efficiency and protection of the property. Networked building technology creates the best prerequisites for this. The intelligent standard for the modern building is the KNX technology. The smart bus system is the only worldwide uniform standard for future-proof building technology. It enables both central and individual linking and control of the individual modules. The JUNG KNX components provide future-proof solutions for the control, visualisation and organisation of building system technology.



#### Façade protection

Weather-dependent automatic shading control protects the façade against unwanted heating from sunlight.

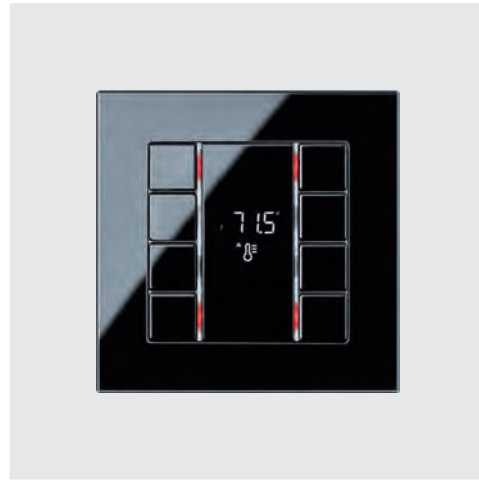

#### Control according to need

Preset comfort scenes and central On/Off push-buttons reduce the energy consumption in the rooms.



#### Protection against water damage

Whether it is a shower that overflows or a burst water pipe: the small aids prevent major damage.



#### Energy Management

Special interfaces record the consumption of gas, water and electricity and energy saving potentials can be recognised and utilised.

### 1.3 Internationality

Thanks to various adapter frames, you are also ideally equipped in an international environment. The inserts and attachments can be combined with a wide variety of flush-mounted and cavity wall boxes. Of course, JUNG also provides international socket systems according to country-specific standards.



British Standard 13 A

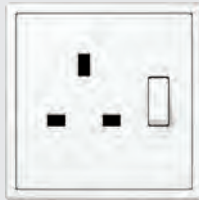

British Standard 13 A, switchable



British Standard 13 A, switchable with indicator lamp



British Standard 5 A



British Standard 15 A



Chinese Standard



G + I socket



Indian Standard



NEMA Standard



NFC Standard



SCHUKO® Standard



SCHUKO® with USB



Swiss System



Electric shaver socket outlet

### 1.3.1 G + I socket

With the G + I socket, JUNG specifically meets the needs of international guests. It combines the British G-plug with the I-plug, which is widely used in Australia, China and Argentina, among other countries. In this way, it covers the connection options of over a third of all countries worldwide. In addition, the G + I socket has been tested: Germany's largest testing company DEKRA attests to the optimum safety of the JUNG G + I socket. The following standards have been tested: IEC60884-1: 2002 + A1: 2006 + A2: 2013 and BSI363-2: 1995 + A4: 2012. Guests and travellers from numerous countries can connect their devices with the combination of G + I socket and SCHUKO® in a two-gang frame. The use of SCHUKO® sockets with USB ports enables even greater flexibility - in the version with JUNG Quick Charge with a particularly high charging capacity.

#### G + I socket and SCHUKO® socket with USB A JUNG Quick Charge®

in a dual frame  
LS 990 in ivory

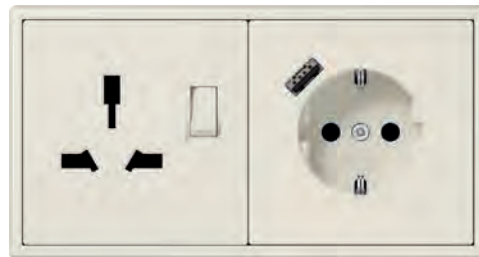

#### G + I socket and SCHUKO® socket with USB-C JUNG Quick Charge®

in a dual frame  
LS 990 in white

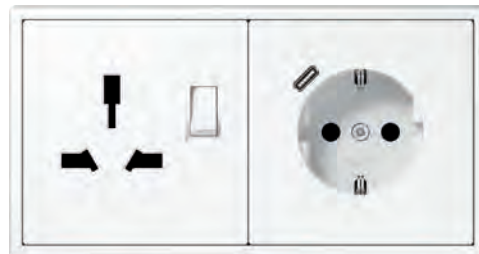

#### G + I socket and SCHUKO® socket with USB A+C

in a dual frame  
LS 990 in black



### 1.3.2 Installation of electric shaver socket outlet

The JUNG electric shaver socket outlets are mounted in double device junction boxes for safe hotel use – both for stone as well as for cavity walls.

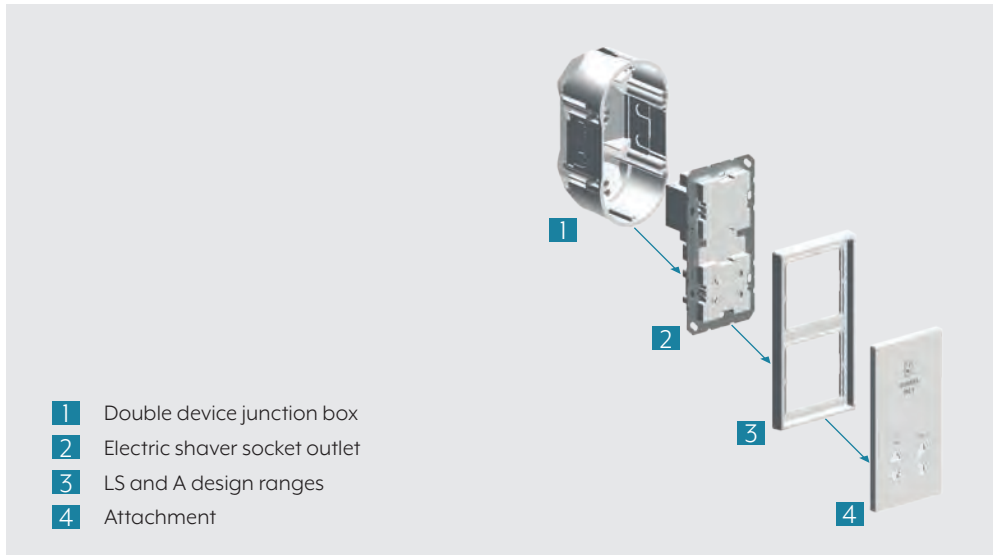

### 1.3.3 Surface-mounted installations

Surface-mounted installations are suitable for structural situations in which no chiselling work can or should be carried out due to particular circumstances.

The particular technical requirements in the hotel can also be stylishly retrofitted for the future.



Surface mounted variant of the LS 990 design classic. The optimal solution if there is no possibility of flush mounting.



The spray water protected surface-mounted solution WG 800. The switches are weather-proof and largely UV-resistant and are suitable for installations in utility rooms, laundries, underground garages or similar.



## 1.4 Comfort for the guest

### 1.4.1 Intuitive operation

A cosy ambience is a basic prerequisite for guests to feel comfortable in the hotel. Intuitive light and room air control, connection options for electrical and multimedia devices as well as stable WLAN reception support the feel-good atmosphere. The elements of the JUNG Hospitality Solutions combine clarity and comprehensibility in the operation and function of the switches with exclusive design.

#### CENTRAL SWITCHING



Practical: switch the lighting in the entire hotel room at the touch of a button.

#### ATMOSPHERIC DIMMING



Create atmosphere: dim the lighting to the desired brightness.

#### CONVENIENCE FUNCTIONS



Combined: control multiple functions or scenes using one device.  
Identified by self-explanatory symbols.







Whether with small or large buttons. Always matching the overall concept. And always intuitively understandable for the guest.

The operating options of the various switches, sensors and dimmers are described in chapter "3.1 Operating philosophy for switching, sensing, dimming" on page 72.

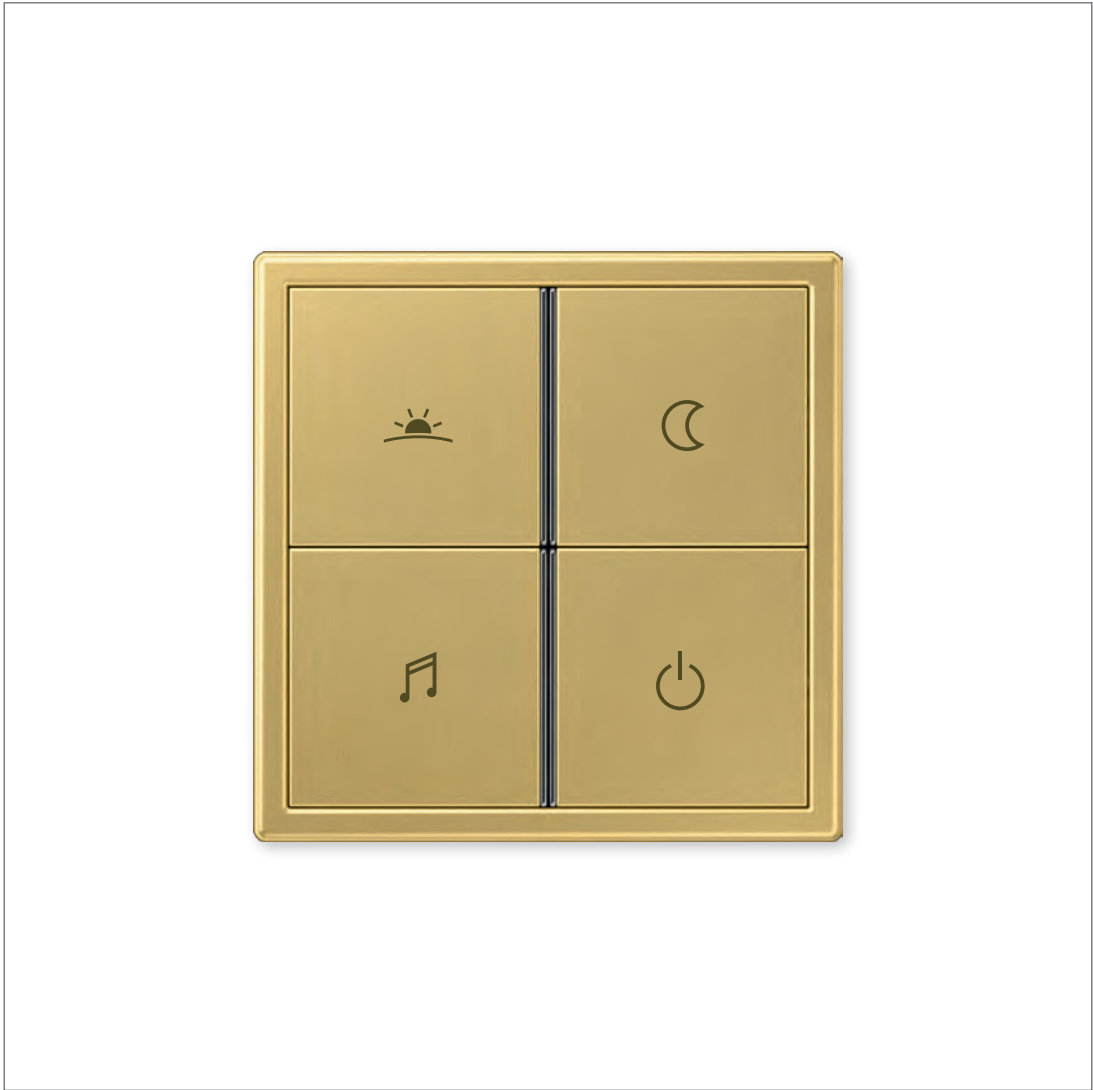
**1.4.2 All-round carefree comfort**

This is smart convenience for the guest: call up different functions together with a single press of a button. Appropriately labelled with understandable symbols as an all-round carefree package.



SYMBOL	SCENE	EXAMPLE FUNCTION
	<b>GOOD MORNING</b>	Open curtains Switch on bedside light Increase ventilation
	<b>NIGHT PEACE</b>	Switch off lighting Close curtains Switch off TV set
	<b>FAVOURITE MUSIC</b>	Operate TV or music system Select suitable lighting
	<b>CENTRAL ON/OFF</b>	Switch all consumers centrally Optimal energy efficiency

### 1.4.3 Full power – sockets with USB port

The new JUNG SCHUKO® sockets with USB ports recharge every battery quickly.

The new inserts are "Made in Germany" and certified by VDE.

New energy without having to occupy the socket with an additional charger. The SCHUKO® sockets with integrated USB ports enable space-saving electrical installation and provide various options for charging different devices. Of course, the new SCHUKO® sockets with USB also have the proven integrated increased contact protection.



#### VDE-certified

JUNG SCHUKO® sockets with USB port are certified by the German VDE (Verband der Elektrotechnik Elektronik Informationstechnik e. V.). The VDE certification mark certifies state-of-the-art product quality and safe use in accordance with the VDE's increased test criteria.

#### USB port & JUNG Quick Charge®

Ideal for cafés, hairdressing salons, hotels or, of course, in your own four walls and in the office – wherever you need new energy for your smart phone or tablet quickly: The version with JUNG Quick Charge® has either a single USB-A or USB-C port and provides an electrical output of 18 watts. Depending on the connected mobile device, JUNG Quick Charge® increases the voltage level to up to 9 volts.

## 1.5 Usefulness for the owner

### 1.5.1 Efficient operations

The JUNG Hospitality Solutions enable the owner to combine modern hotel and control software with stylish controls. The interface of the JUNG Visu Pro software supports efficient processing in the daily hotel routine. JUNG provides the Hotel Display to simplify the direct communication between guest and housekeeping.

"Do not disturb" or "Make up room": The corresponding lit LED indicates the guest's wish in the corridor. The integration of card readers in the JUNG system can also be realised.

#### LINK WITH POWERFUL HOTEL SOFTWARE



The front office works with well-known user interfaces; however hotel and control software behind this are connected with each other. Preset profiles are activated directly with the check-in. Wishes of the guest reach the personnel via notification on the monitor.

#### SMART INTERFACE

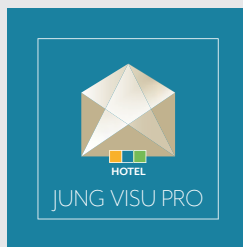

The core is the JUNG Visu Pro software with integrated interfaces to Protel and Micros Fidelio (Oracle). Hotel and control software are intelligently linked.

#### ECOLOGY AND ECONOMY



More energy efficiency and thus economy: automated temperature profiles also prevent the heating and cooling of unused rooms.

## 1.5.2 Smart solutions for the hotel

Structured work processes and well-coordinated internal coordination are also extremely important for the personnel. Smart JUNG building technology supports the efficient processing here in the everyday hotel routine.

### CENTRAL SOFTWARE

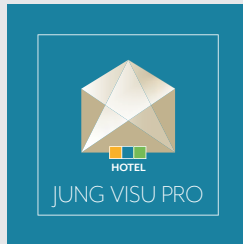

The basis is the JUNG Visu Pro software. It structures, organises and visualises the processes for the personnel.

### CENTRAL DISPLAY



The room states are clearly displayed on centrally positioned panels.

### MOBILE CONTROL



Tasks are shown on a smart phone, the personal can tick off completed work directly.

### SMART INTERFACE



The function islands of the JUNG building technology are reliably linked with each other via the separate IP backbone.





## 2. APPLICATION EXAMPLES

<b>2.1 HOTEL ROOM</b>	<b>32</b>
2.1.1 Economy	34
2.1.2 Mid-scale	42
2.1.3 Luxury A	50
2.1.4 Luxury B	60

## 2. Application examples

### 2.1 Hotel room

The hotel room is the focus of the stay. Every guest wants to feel comfortable according to their needs and possibilities. Whether it is a short business trip, an extended weekend in an exciting city or a luxurious wellness holiday: the hotel room is at the centre of the stay.

Every owner has different requirements for his hotel. Whether it is an Economy, a Mid-scale or a Luxury room, one thing always remains the same: the guest wants to feel comfortable from the moment he enters the room until the moment he leaves. JUNG provides the appropriate components for all variants in order to enable the greatest possible comfort for the guest, clarity for the personnel and efficiency for the owner in every price class. With the international usability, JUNG also guarantees the equipment for globally operating hotel chains with recognition guarantee.

The application examples shown here, including circuit and wiring diagrams, are available for download online at [jung-group.com/hotel-usecases](http://jung-group.com/hotel-usecases)







### 2.1.1 Economy

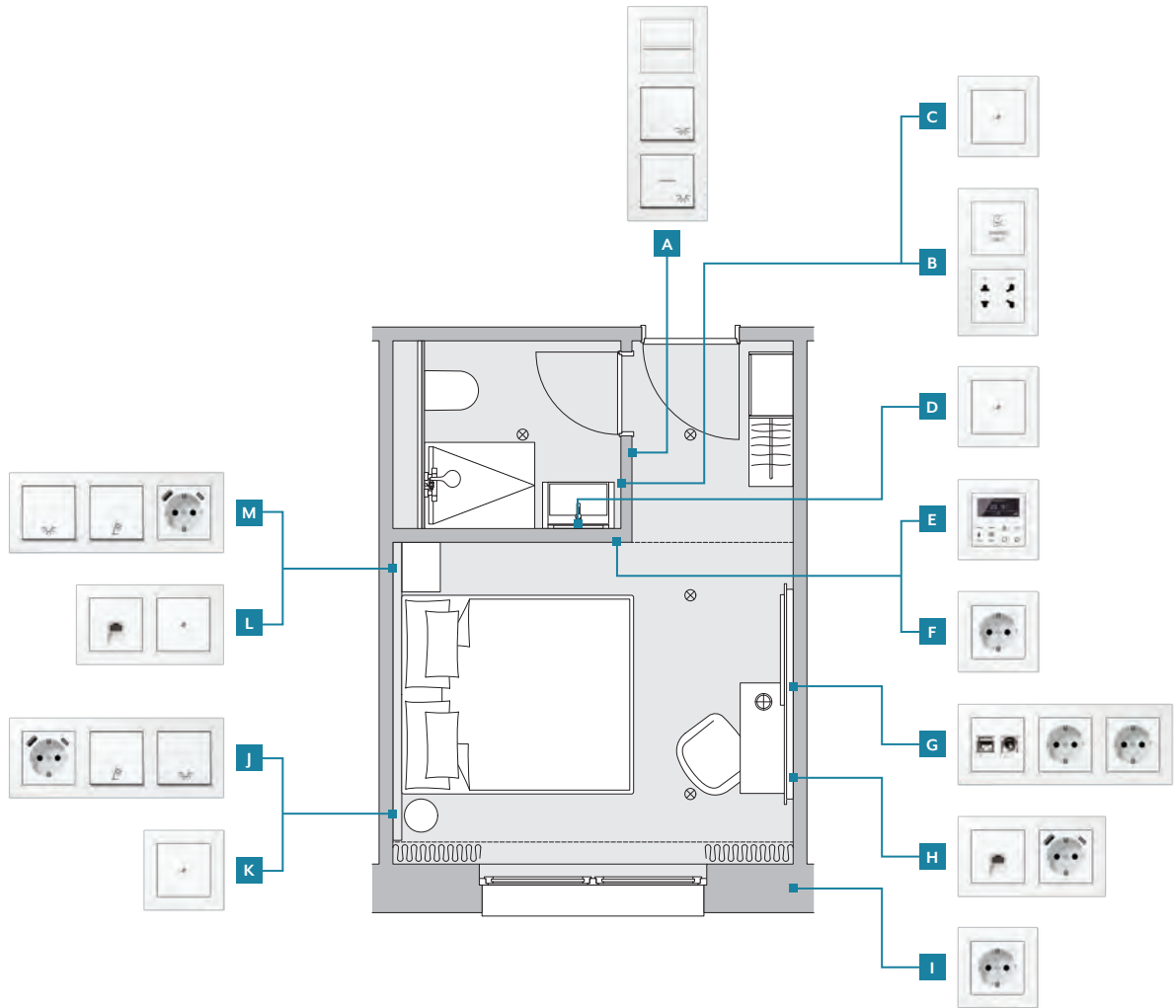

For a detailed view of the graphics, individual units are shown magnified here.

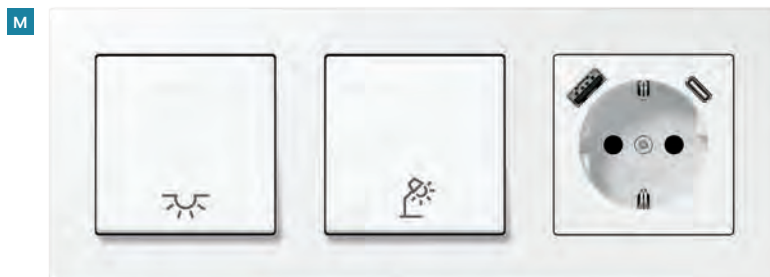

## WALL DEVELOPMENT I



POS.	COMPONENTS	REF. NO.	QUANTITY
G	SCHUKO® socket A range, breakproof, white	A1520BFWW	2
	Smart TV wall box, A range, white	MMDA452IWW	1
	3-gang frame A 550 range, breakproof, white	A5583BFWW	1
H	IAE/UAE socket	UAE8UPO	1
	Cover UAE socket A range, breakproof, white	A596-1BFPLUAWW	1
	SCHUKO® socket with USB charger, A range, white	A 1520-15 CA WW	1
	2-gang frame A 550 range, breakproof, white	A5582BFWW	1
I	SCHUKO® socket A range, breakproof, white	A1520BFWW	1
	1-gang frame A 550 range, breakproof, white	A5581BFWW	1

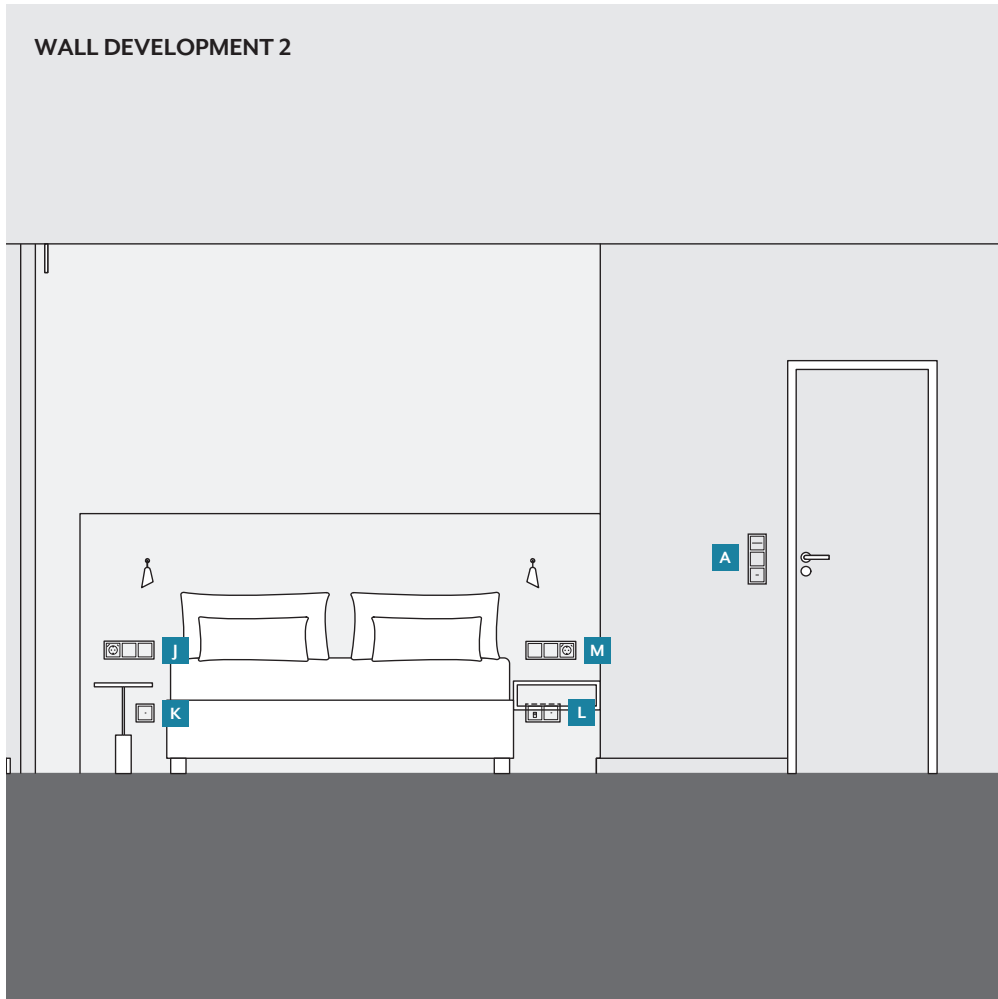

POS.	COMPONENTS	REF. NO.	QUANTITY
A	Energy saving unit	ESU230-2	1
	RFID key card holder, A range, white	ACARDRFIDWW	1
	Cross rocker switch	507U	1
	Rocker, A range, breakproof, white	A590BFWW	1
	Universal 1-pole, 2-way switch with indicator light	506KOU	1
	Rocker with symbol "light", A range, breakproof, white	A590BFKO5LWW	1
	3-gang frame A 550 range, breakproof, white	A5583BFWW	1
J/M	SCHUKO® socket with USB charger, A range, white	A 1520-15 CA WW	2
	Universal 1-pole, 2-way rocker switch	506U	4
	Rocker, A range, breakproof, white	A590BFWW	4
	3-gang frame A 550 range, breakproof, white	A5583BFWW	2
K	Cable outlet, A range, breakproof, white	A590BFAWW	1
	1-gang frame A 550 range, breakproof, white	A5581BFWW	1
L	IAE/UAE socket	UAE8UPO	1
	Cover UAE socket A range, breakproof, white	A596-1BFPLUAWW	1
	Cable outlet, A range, breakproof, white	A590BFAWW	1
	2-gang frame A 550 range, breakproof, white	A5582BFWW	1

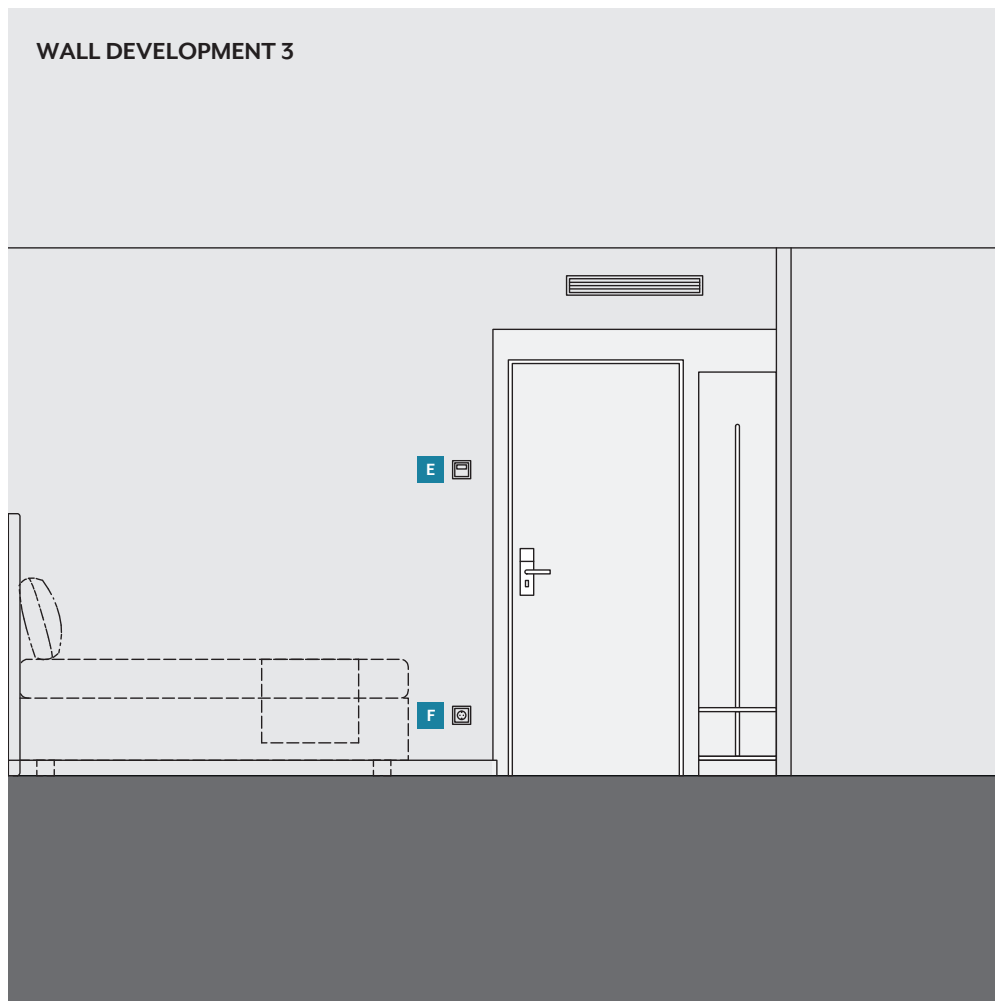

POS.	COMPONENTS	REF. NO.	QUANTITY
E	Room thermostat fan coil, 4-pipe, A range, white	TRDA523048WW	1
	1-gang frame A 550 range, breakproof, white	A5581BFWW	1
F	SCHUKO® socket A range, breakproof, white	A1520BFWW	1
	1-gang frame A 550 range, breakproof, white	A5581BFWW	1

## WALL DEVELOPMENT 4



POS.	COMPONENTS	REF. NO.	QUANTITY
B	Electric shaver socket outlet insert	SO7522EINS	1
	Cover electric shaver socket outlet, A range, breakproof, white	SOA7522BFWWPL	1
	2-gang frame A 550 range, breakproof, white	A5582BFWW	1
C	Cable outlet, A range, breakproof, white	A590BFAWW	1
	1-gang frame A 550 range, breakproof, white	A5581BFWW	1

## WALL DEVELOPMENT 5

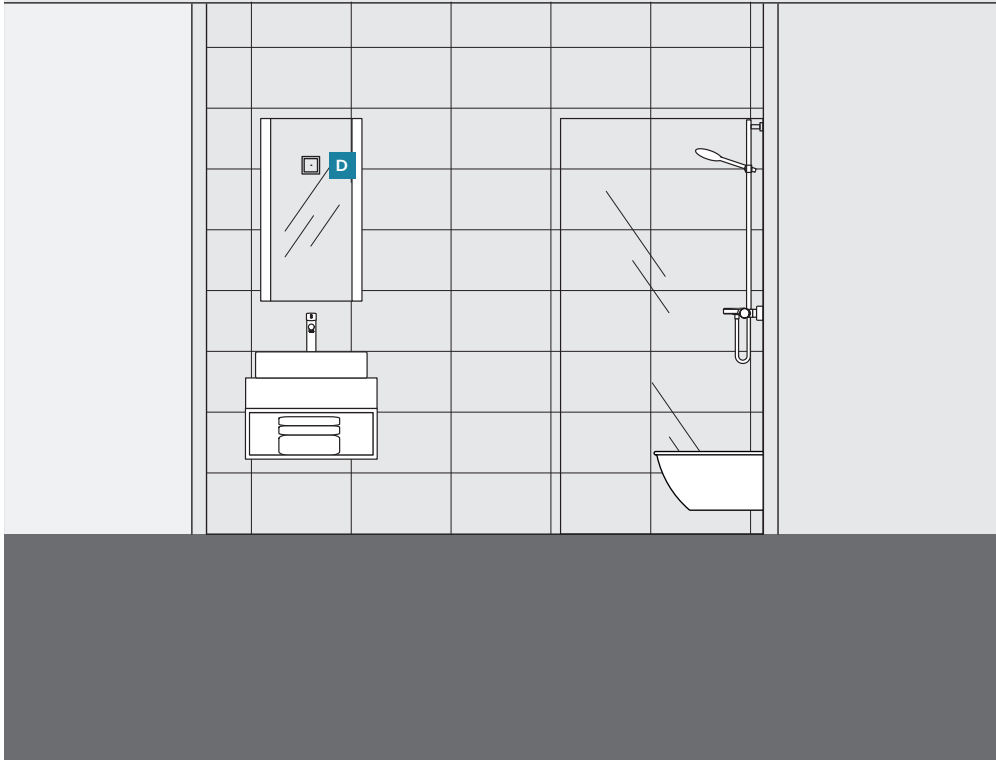

POS.	COMPONENTS	REF. NO.	QUANTITY
D	Cable outlet, A range, breakproof, white	A590BFAWW	1
	1-gang frame A 550 range, breakproof, white	A558IBFWW	1





### 2.1.2 Mid-scale

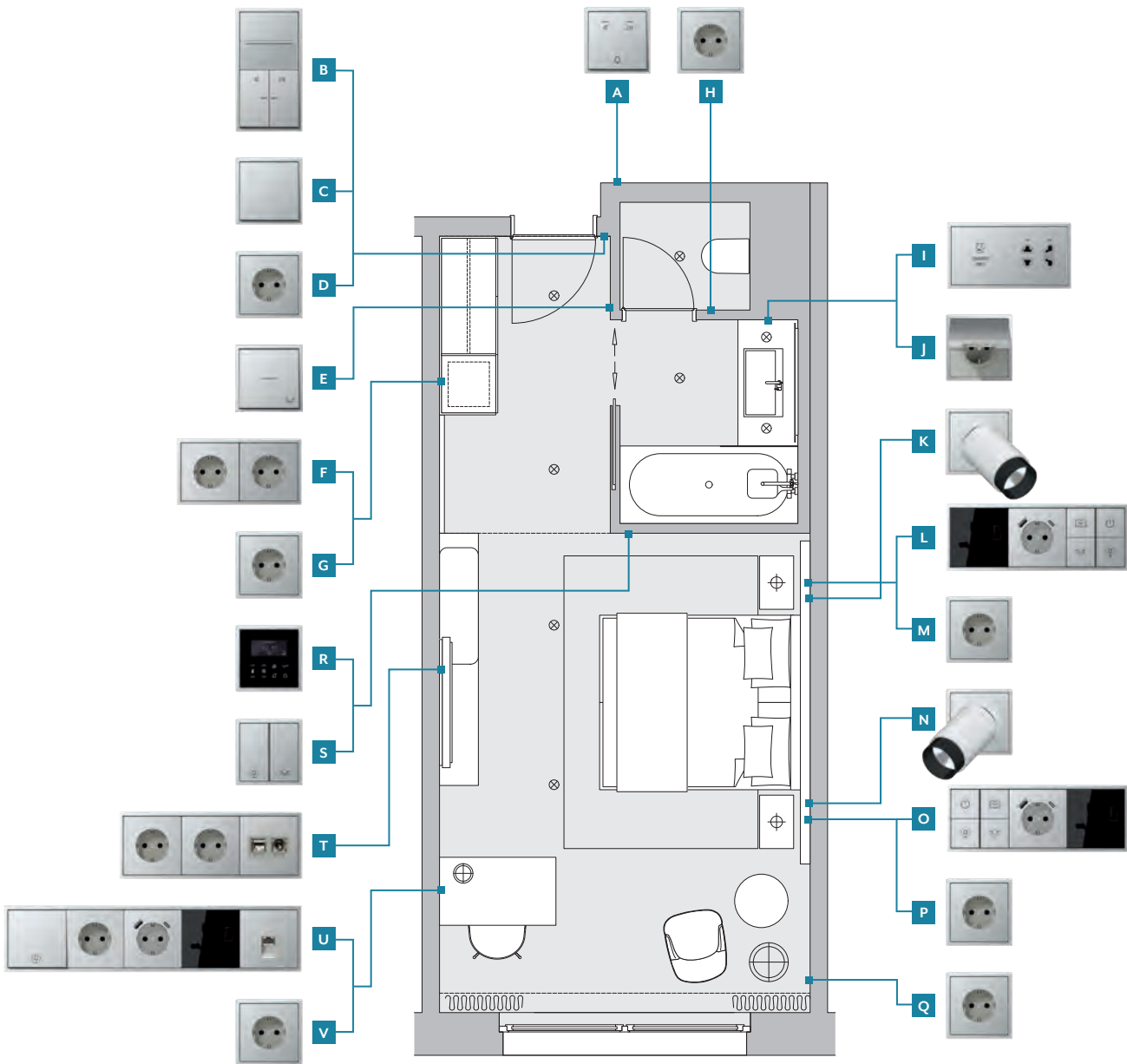

For a detailed view of the graphics, individual units are shown magnified here.

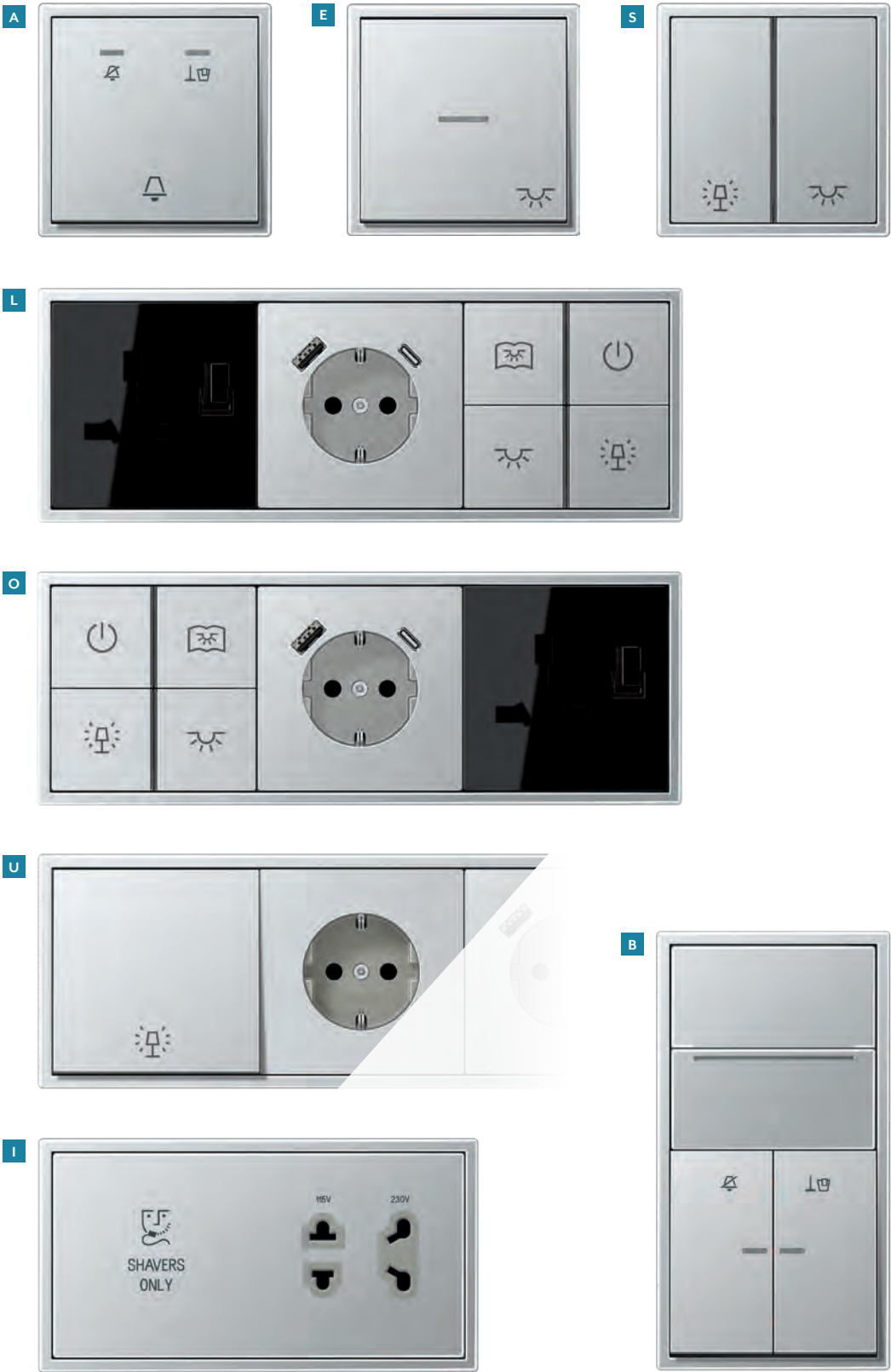

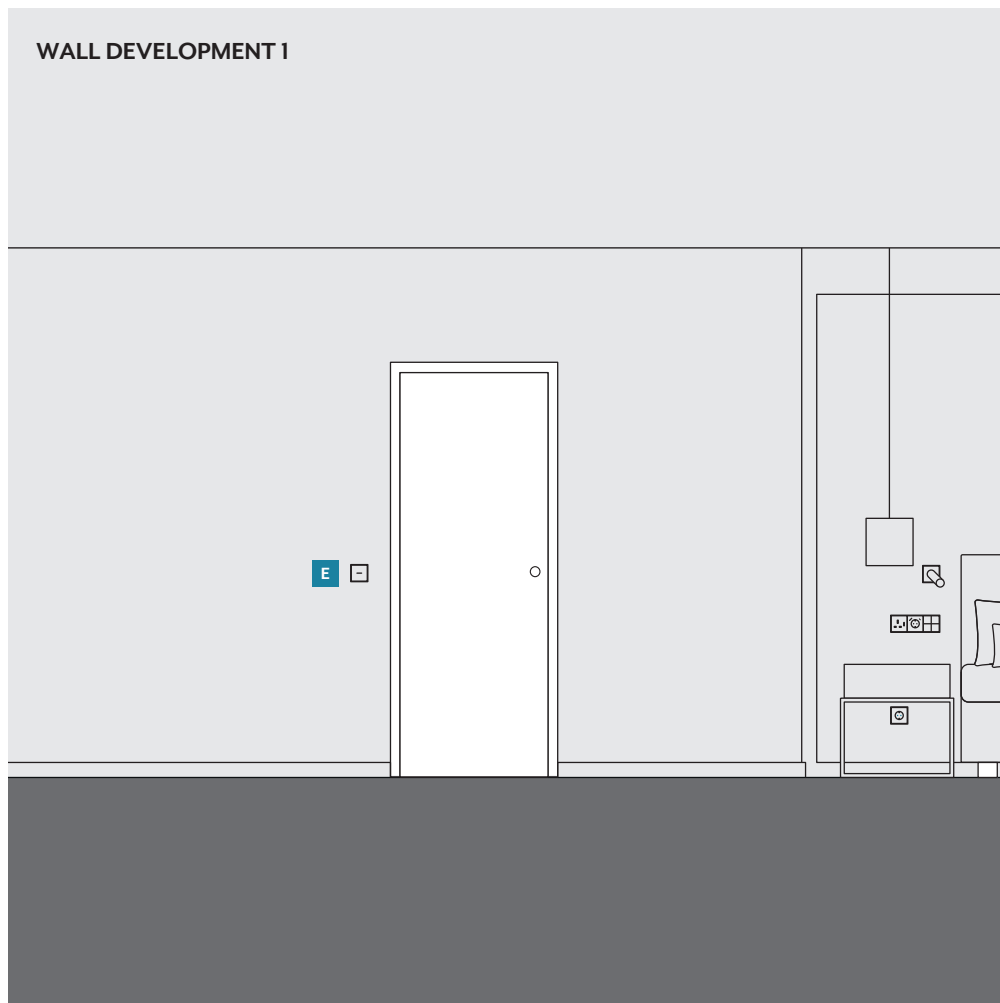

POS.	COMPONENTS	REF. NO.	QUANTITY
E	Push-button, 1-pole NO contact with separate signal contact	534U	1
	Rocker with symbol "light", LS range, aluminium	AL2990KO5L	1
	1-gang frame, LS 990 range, aluminium	AL2981	1

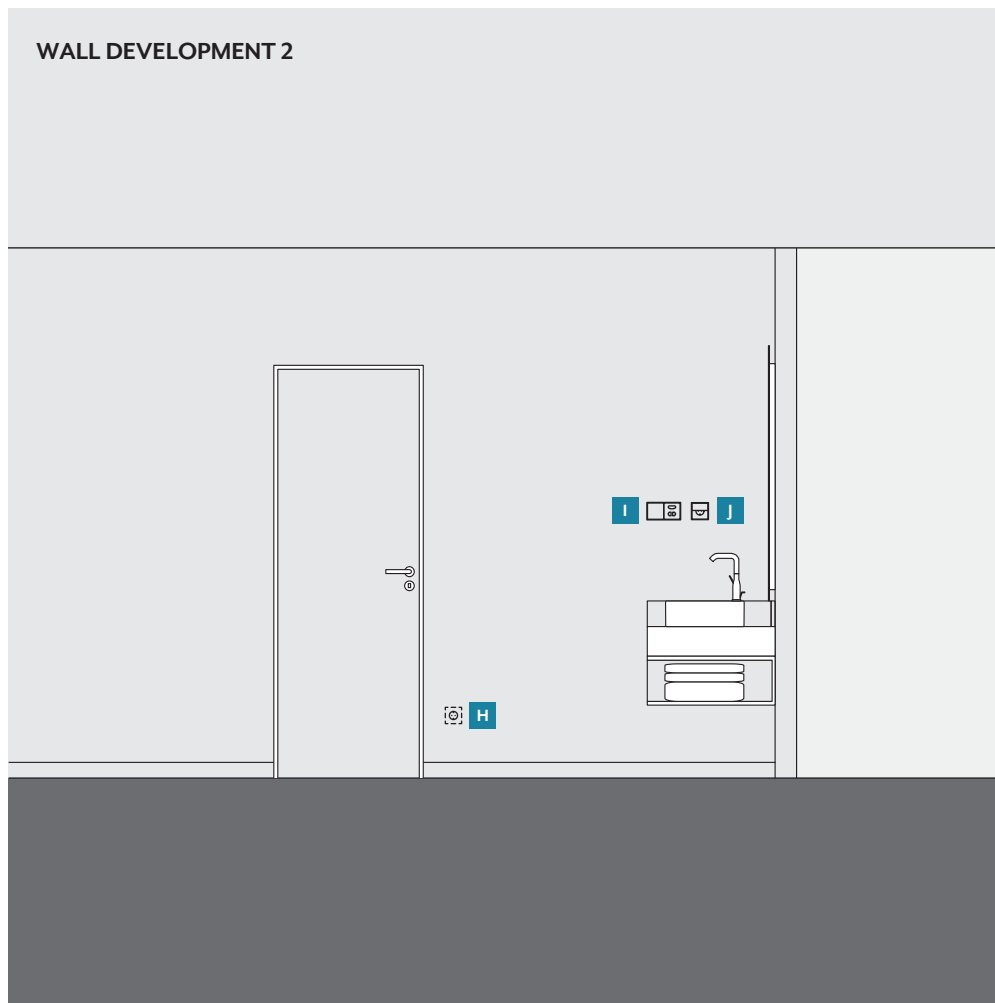

POS.	COMPONENTS	REF. NO.	QUANTITY
H	SCHUKO® socket, LS range, aluminium	AL1520	1
	1-gang frame, LS 990 range, aluminium	AL2981	1
I	Electric shaver socket outlet insert	SO7522EINS	1
	Cover electric shaver socket outlet, LS range, aluminium	SOAL7522PL	1
	2-gang frame, LS 990 range, aluminium	AL2982	1
J	SCHUKO® socket with hinged lid, aluminium	AL1520 KIKL	1
	Sealing gasket	55IWU	1
	1-gang frame, LS 990 range, aluminium	AL2981	1

## WALL DEVELOPMENT 3

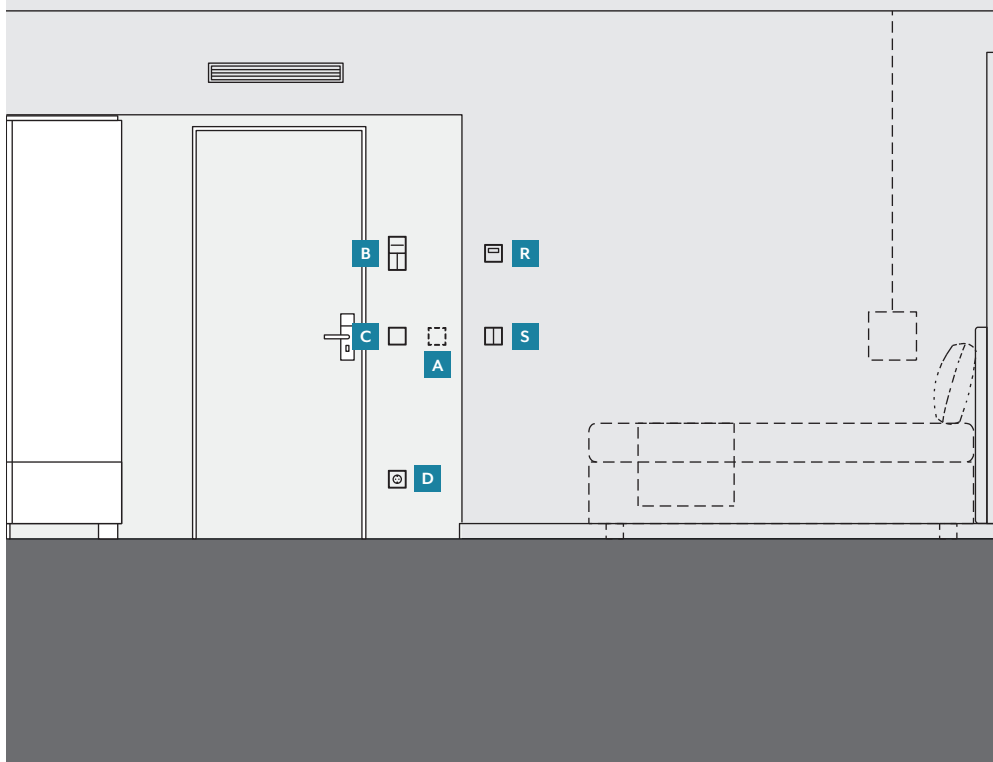

POS.	COMPONENTS	REF. NO.	QUANTITY
A	Hotel cover LED 230 V, corridor unit, LS range, aluminium	ALCUKO5M230	1
	1-gang frame, LS 990 range, aluminium	AL2981	1
B	Energy saving unit	ESU230-2	1
	RFID key card holder, LS range, aluminium	ALCARDRFID	1
	Hotel switch insert, room unit	505KO5VEUM230	1
	Hotel rocker, room unit, LS range, aluminium	ALRUKO5M	1
	2-gang frame, LS 990 range, aluminium	AL2982	1
C	Push-button, 1-pole NO contact	53IU	1
	Rocker, LS range, aluminium	AL2990	1
	1-gang frame, LS 990 range, aluminium	AL2981	1
D	SCHUKO® socket, LS range, aluminium	AL1520	1
	1-gang frame, LS 990 range, aluminium	AL2981	1
R	Room thermostat fan coil, 4-pipe, LS range, black	TRDLS923048 SW	1
	1-gang frame, LS 990 range, aluminium	AL2981	1
S	Push-button module 24 V AC/DC, 2-gang	4224TSM	1
	Cover kit, 2-gang, LS range, aluminium	AL2402TSA	1
	1-gang frame, LS 990 range, aluminium	AL2981	1

## WALL DEVELOPMENT 4



POS.	COMPONENTS	REF. NO.	QUANTITY
K/N	Power supply Plug & Light	PL08U	2
	Cover Plug & Light, LS range, aluminium (lacquered)	PLALDMS-L	2
	Plug & Light LED spotlight, aluminium-black	PLSID05ALSW	2
	1-gang frame, LS 990 range, aluminium	AL2981	2
L/O	Push-button module 24 V AC/DC, 4-gang	4248TSM	2
	Cover kit, 4-gang, LS range, aluminium	AL2404TSA	2
	SCHUKO® socket with USB charger CA, LS range, aluminium	AL1520-15CA-L	2
	Socket type G+I, LS range, black	LS4171 GI SW SW	2
	3-gang frame, LS 990 range, aluminium	AL2983	2
M	SCHUKO® socket, LS range, aluminium	AL1520	1
	1-gang frame, LS 990 range, aluminium	AL2981	1
P	SCHUKO® socket, LS range, aluminium	AL1520	1
	1-gang frame, LS 990 range, aluminium	AL2981	1
Q	SCHUKO® socket, LS range, aluminium	AL1520	1
	1-gang frame, LS 990 range, aluminium	AL2981	1

## WALL DEVELOPMENT 5

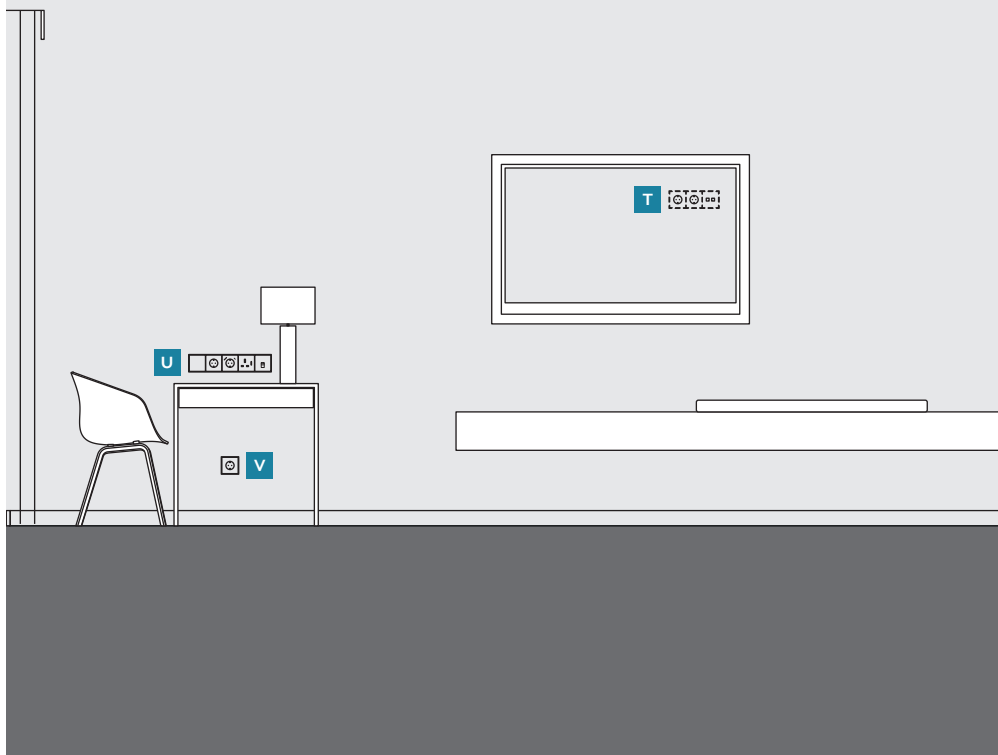

POS.	COMPONENTS	REF. NO.	QUANTITY
T	SCHUKO® socket, LS range, aluminium	AL1520	2
	Cover UMA-CAT6	AL1969-2WE	1
	3-gang frame, LS 990 range, aluminium	AL2983	1
U	Push-button, 1-pole NO contact	53IU	1
	Rocker, LS range, aluminium	AL2990	1
	SCHUKO® socket, LS range, aluminium	AL1520	1
	SCHUKO® socket with USB charger CA, LS range, aluminium	AL1520-15CA-L	1
	Socket type G+I, LS range, black	LS4171 GI SW SW	1
	WLAN Access Point	WLAN-AC-UAE	1
	Cover IAE/UAE socket, LS range, aluminium	AL2969-1UA	1
	5-gang frame, LS 990 range, aluminium	AL2985	1
V	SCHUKO® socket, LS range, aluminium	AL1520	1
	1-gang frame, LS 990 range, aluminium	AL2981	1



## WALL DEVELOPMENT 6



POS.	COMPONENTS	REF. NO.	QUANTITY
F	SCHUKO® socket, LS range, aluminium	AL1520	2
	2-gang frame, LS 990 range, aluminium	AL2982	1
G	SCHUKO® socket, LS range, aluminium	AL1520	1
	1-gang frame, LS 990 range, aluminium	AL2981	1

### 2.1.3 Luxury A

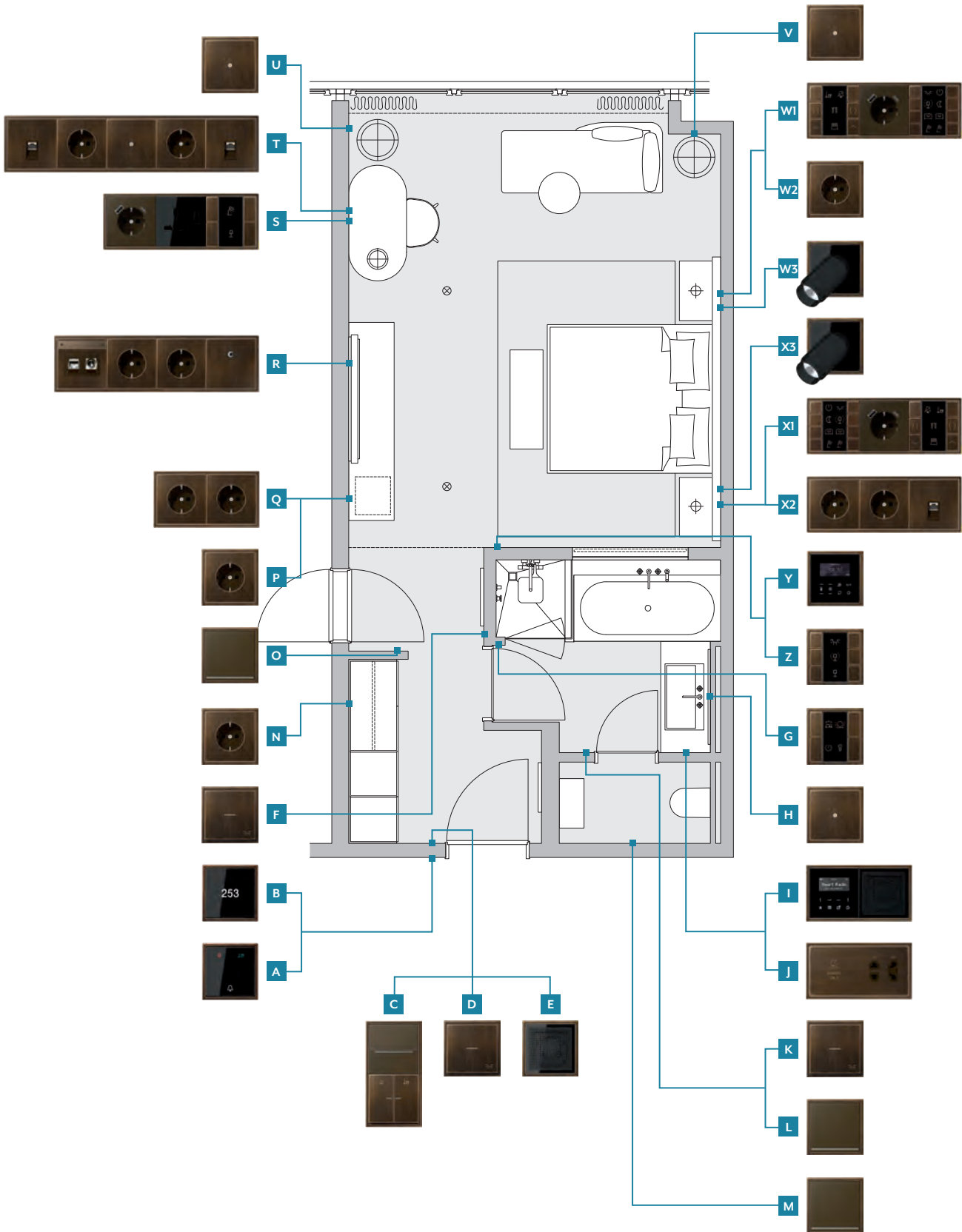

For a detailed view of the graphics, individual units are shown magnified here.



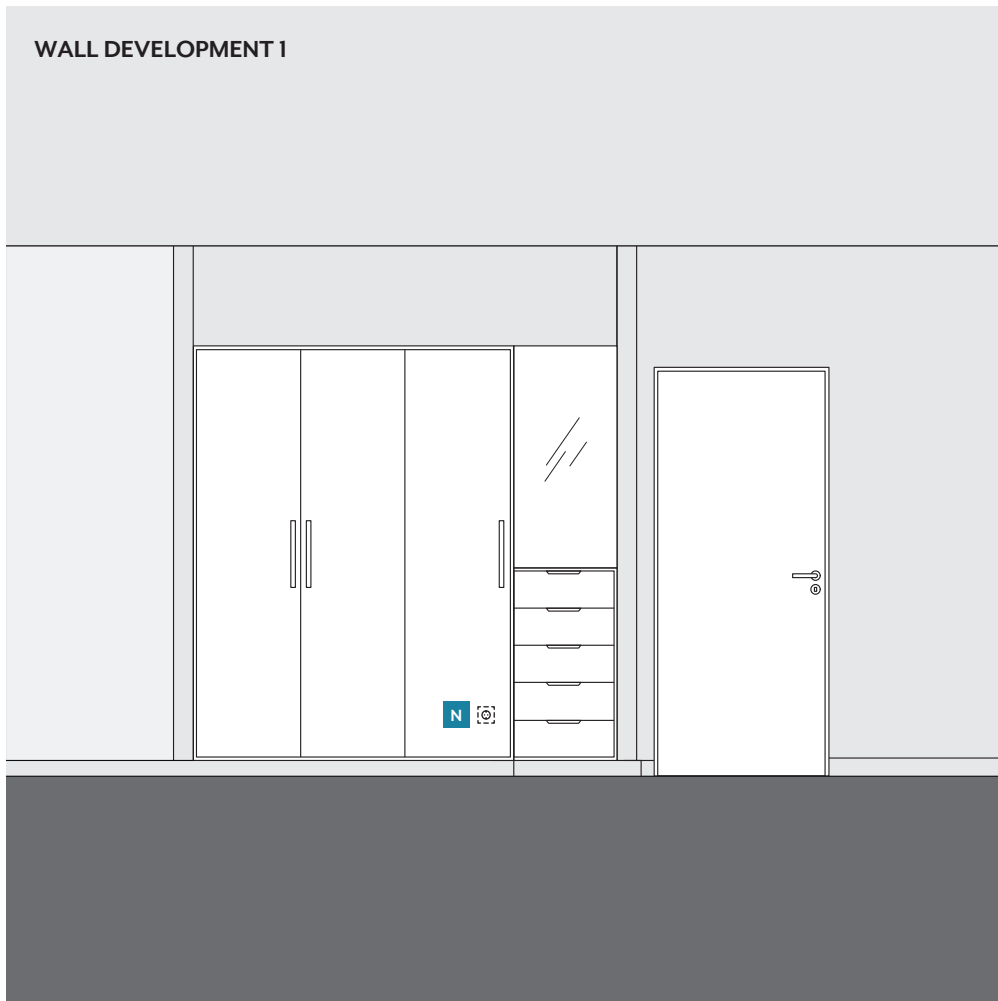

POS.	COMPONENTS	REF. NO.	QUANTITY
N	SCHUKO® socket, LS range, antique brass	ME1520AT	1
	I-gang frame, LS 990 range, antique brass	ME2981AT	1

## WALL DEVELOPMENT 2



POS.	COMPONENTS	REF. NO.	QUANTITY
P	SCHUKO® socket, LS range, antique brass	ME1520AT	1
	1-gang frame, LS 990 range, antique brass	ME2981AT	1
Q	SCHUKO® socket, LS range, antique brass	ME1520AT	2
	2-gang frame, LS 990 range, antique brass	ME2982AT	1
R	Smart TV wall box with inscription field, LS range in antique brass	On request	1
	SCHUKO® socket, LS range, antique brass	ME1520AT	2
	Multimedia connection, 3.5 jack, LS range, antique brass	On request	1
	4-gang frame, LS 990 range, antique brass	ME2984AT	1
S	SCHUKO® socket with USB charger CA, LS range, antique brass	ME1520-15 CA AT-L	1
	Socket type G+I, LS range, black	LS4171 GI SW SW	1
	KNX push-button sensor F 50 Universal, 2-gang	LS5092TSM	1
	Cover kit, 2-gang, LS range, antique brass	ME2502TSAAT	1
	3-gang frame, LS 990 range, antique brass	ME2983AT	1
T	IAE/UAE socket	UAE8UPO	1
	Cover IAE/UAE, LS range, antique brass	ME2969-1UAAT	1
	SCHUKO® socket, LS range, antique brass	ME1520AT	1
	Cable outlet with strain relief, LS range, antique brass	ME2990AAT	1
	SCHUKO® socket, LS range, antique brass	ME1520AT	1
	WLAN Access Point	WLAN-AC-UAE	1
	Cover WLAN Access Point, LS range, antique brass	ME2969-1UAAT	1
5-gang frame, LS 990 range, antique brass	ME2985AT	1	
U	Cable outlet with strain relief, LS range, antique brass	ME2990AAT	1
	1-gang frame, LS 990 range, antique brass	ME2981AT	1

## WALL DEVELOPMENT 3



POS.	COMPONENTS	REF. NO.	QUANTITY
W3 / X3	Power supply Plug & Light	PL08U	2
	Cover Plug & Light, LS range, thermoplastic, high-gloss, black	PLLSDMSSW	2
	Plug & Light LED spotlight, thermoplastic, black	PLSID05SWSW	2
	1-gang frame, LS 990 range, antique brass	ME2981AT	2
V	Cable outlet with strain relief, LS range, antique brass	ME2990AAT	1
	1-gang frame, LS 990 range, antique brass	ME2981AT	1
W1 / X1	KNX push-button sensor F 50 Universal, 3-gang	LS5093TSM	2
	Cover kit, 3-gang, LS range, antique brass	ME2503TSAAT	2
	SCHUKO® socket with USB charger CA, LS range, antique brass	MEI520-15CAAT-L	2
	KNX push-button sensor F 50 Universal, 4-gang	LS5094TSM	2
	Cover kit, 4-gang, LS range, antique brass	ME2504TSAAT	2
	3-gang frame, LS 990 range, antique brass	ME2983AT	2
W2	SCHUKO® socket, LS range, antique brass	MEI520AT	1
	1-gang frame, LS 990 range, antique brass	ME2981AT	1
X2	SCHUKO® socket, LS range, antique brass	MEI520AT	2
	IAE/UAE socket	UAE8UPO	1
	Cover IAE/UAE, LS range, antique brass	ME2969-1UAAT	1
	3-gang frame, LS 990 range, antique brass	ME2983AT	1

## WALL DEVELOPMENT 4

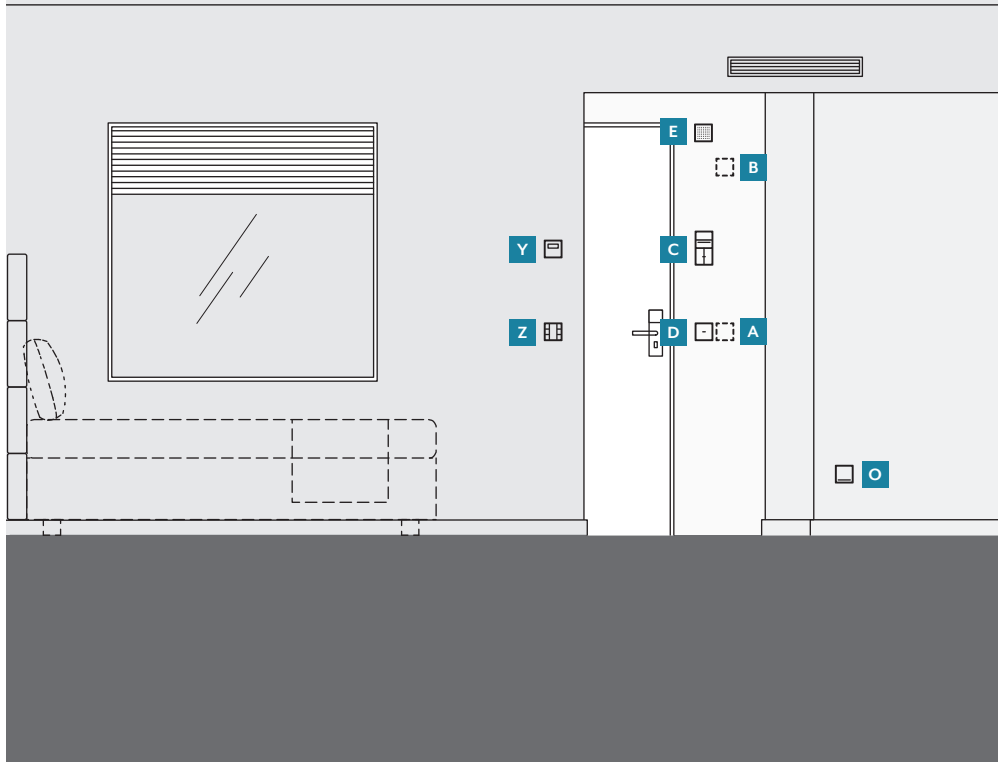

POS.	COMPONENTS	REF. NO.	QUANTITY
A	Hotel push-button insert, corridor unit, 1 pole NO contact, 230 V	53IKO5EUM230	1
	Hotel rocker, glass, corridor unit, LS range, black	LSCUKO6MSW	1
	1-gang frame, LS 990 range, antique brass	ME2981AT	1
B	LED pilot light insert	LEDKO6TX24	1
	Glass cover, LS range, black	Labelling tool	1
	1-gang frame, LS 990 range, antique brass	ME2981AT	1
C	Energy saving unit	ESU230-2	1
	RFID key card holder, LS range, antique brass	MECARDRFIDAT	1
	KNX push-button Universal, 2-gang	LSCDI092IST	1
	Hotel rocker, room unit, LS range, antique brass	On request	1
	2-gang frame, LS 990 range, antique brass	ME2982AT	1
D	KNX push-button Standard, 1-gang	LSCDI071IST	1
	Rocker with indicator light, LS range, antique brass	ME101KO5AT	1
	1-gang frame, LS 990 range, antique brass	ME2981AT	1
E	Triple-tone signal	On request	1
	1-gang frame, LS 990 range, antique brass	ME2981AT	1
O	LED pilot light, LS range, antique brass	MEI539-OOATLNW	1
	1-gang frame, LS 990 range, antique brass	ME2981AT	1
Y	KNX Temperature controller fan coil, LS range, black	TRDLS9248SW	1
	1-gang frame, LS 990 range, antique brass	ME2981AT	1
Z	KNX push-button sensor F 50 Universal, 3-gang	LS5093TSM	1
	Cover kit, 3-gang, LS range, antique brass	ME2503TSAAT	1
	1-gang frame, LS 990 range, antique brass	ME2981AT	1

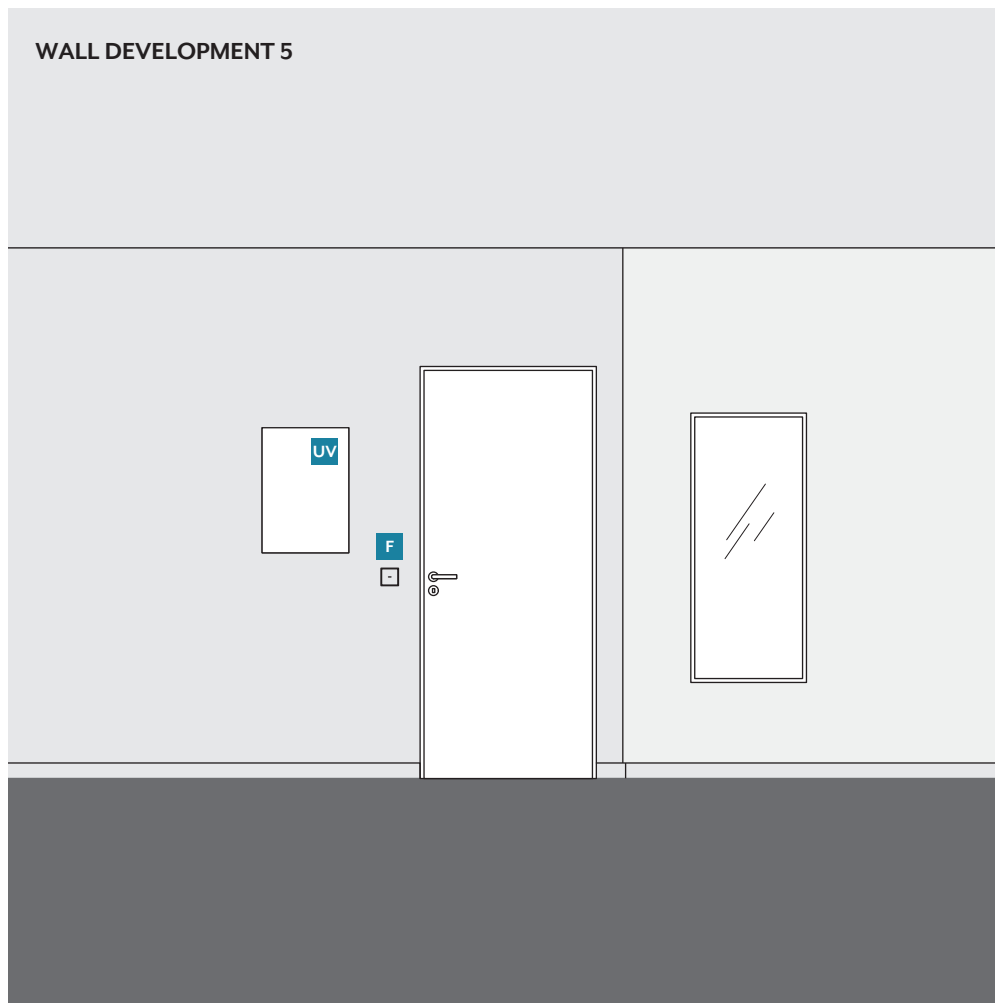

POS.	COMPONENTS	REF. NO.	QUANTITY
F	KNX push-button Standard, 1-gang	LSCDI0711ST	1
	Rocker with indicator light, LS range, antique brass	ME10IKO5AT	1
	1-gang frame, LS 990 range, antique brass	ME298IAT	1

POS.	COMPONENTS	REF. NO.	QUANTITY
Distribution board	Power supply 24 V DC, for rail mounting	NT2415REGVDC	1
	KNX power supply with IP interface	20320ISIPSR	1
	KNX switch/blind actuator 24/12-gang	23024ISR	1
	KNX LED Universal dimming actuator, 2-gang	3902REGHE	1
	KNX 6-gang binary input	2116REG	1



## WALL DEVELOPMENT 6

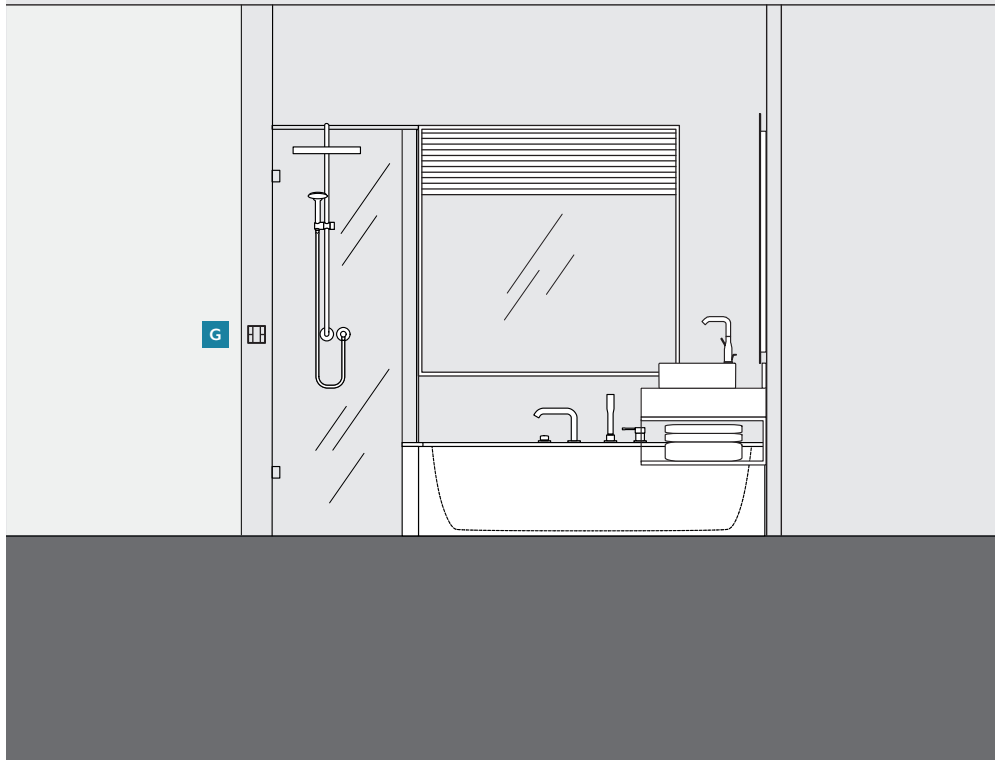

POS.	COMPONENTS	REF. NO.	QUANTITY
G	KNX push-button sensor F 50 Universal, 2-gang	LS5092TSM	1
	Cover kit, 2-gang, LS range, antique brass	ME2502TSAAT	1
	1-gang frame, LS 990 range, antique brass	ME2981AT	1

## WALL DEVELOPMENT 7

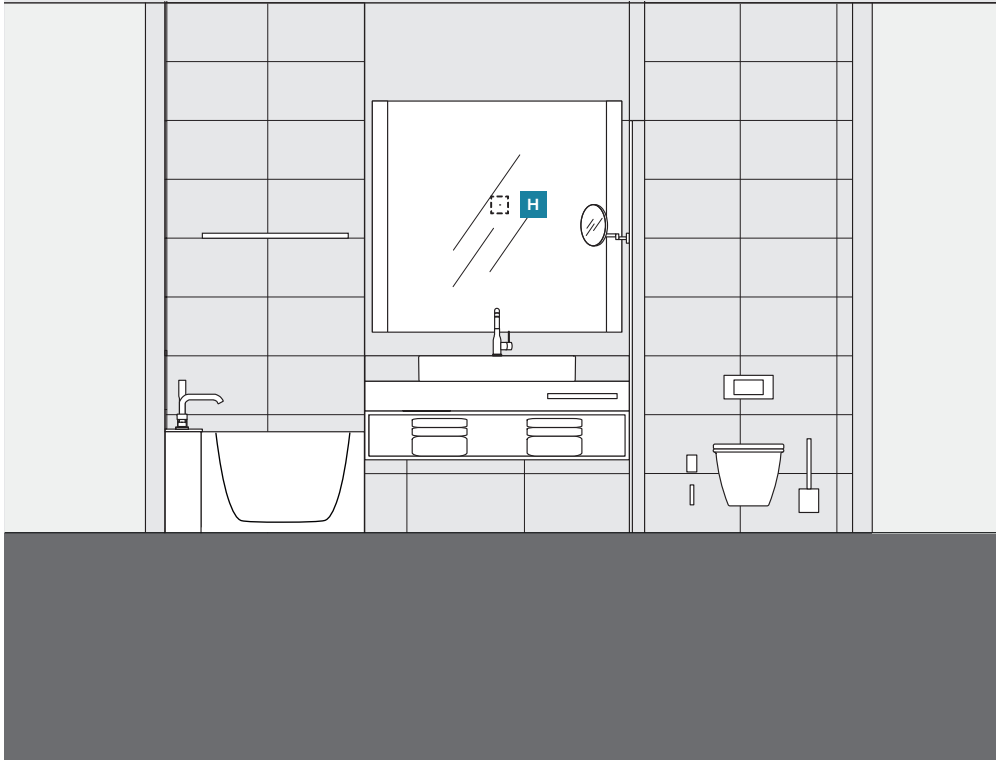

POS.	COMPONENTS	REF. NO.	QUANTITY
H	Cable outlet with strain relief, LS range	ME2990AAT	1
	1-gang frame, LS 990 range, antique brass	ME2981AT	1

## WALL DEVELOPMENT 8

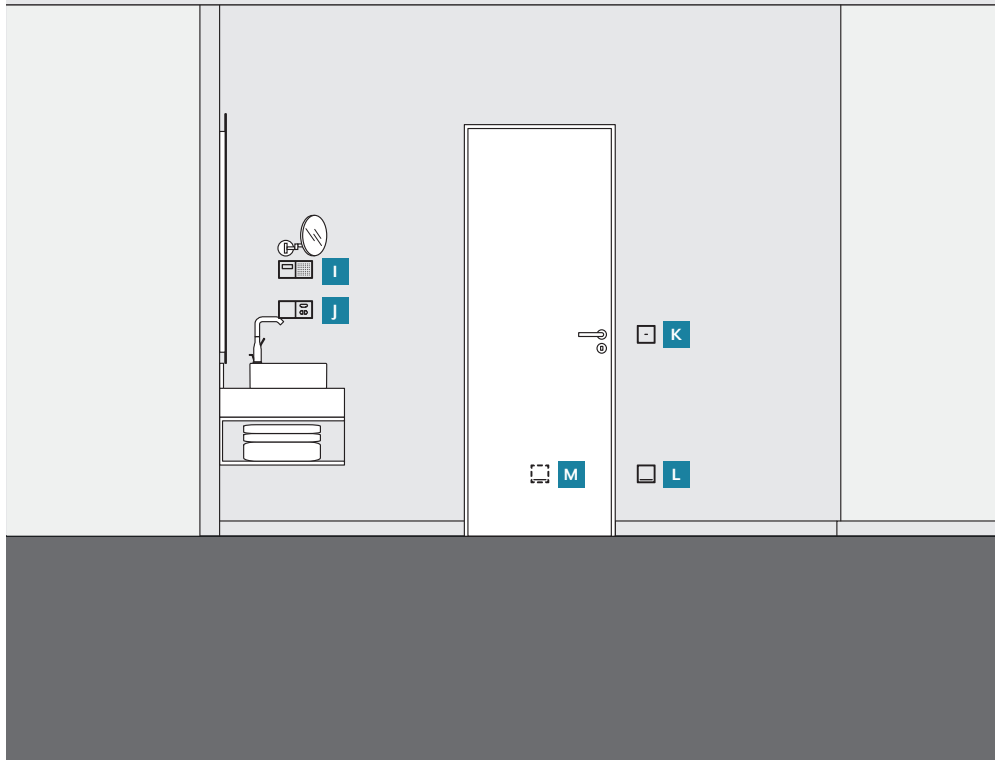

POS.	COMPONENTS	REF. NO.	QUANTITY
K	KNX push-button Standard, 1-gang	LSCD10711ST	1
	Rocker with indicator light, LS range, antique brass	ME101KO5AT	1
	1-gang frame, LS 990 range, antique brass	ME2981AT	1
I	Smart Radio DAB+ Bluetooth, mono LS range, black	DABLSIBTSW	1
	2-gang frame, LS 990 range, antique brass	ME2982AT	1
J	Electric shaver socket outlet insert	SO7522EINS	1
	Cover electric shaver socket outlet, LS range, antique brass, horizontal	On request	1
	2-gang frame, LS 990 range, antique brass	ME2982AT	1
L	LED pilot light, LS range, antique brass	ME1539-OOATLNW	1
	1-gang frame, LS 990 range, antique brass	ME2981AT	1
M	LED pilot light, LS range, antique brass	ME1539-OOATLNW	1
	1-gang frame, LS 990 range, antique brass	ME2981AT	1

### 2.1.4 Luxury B

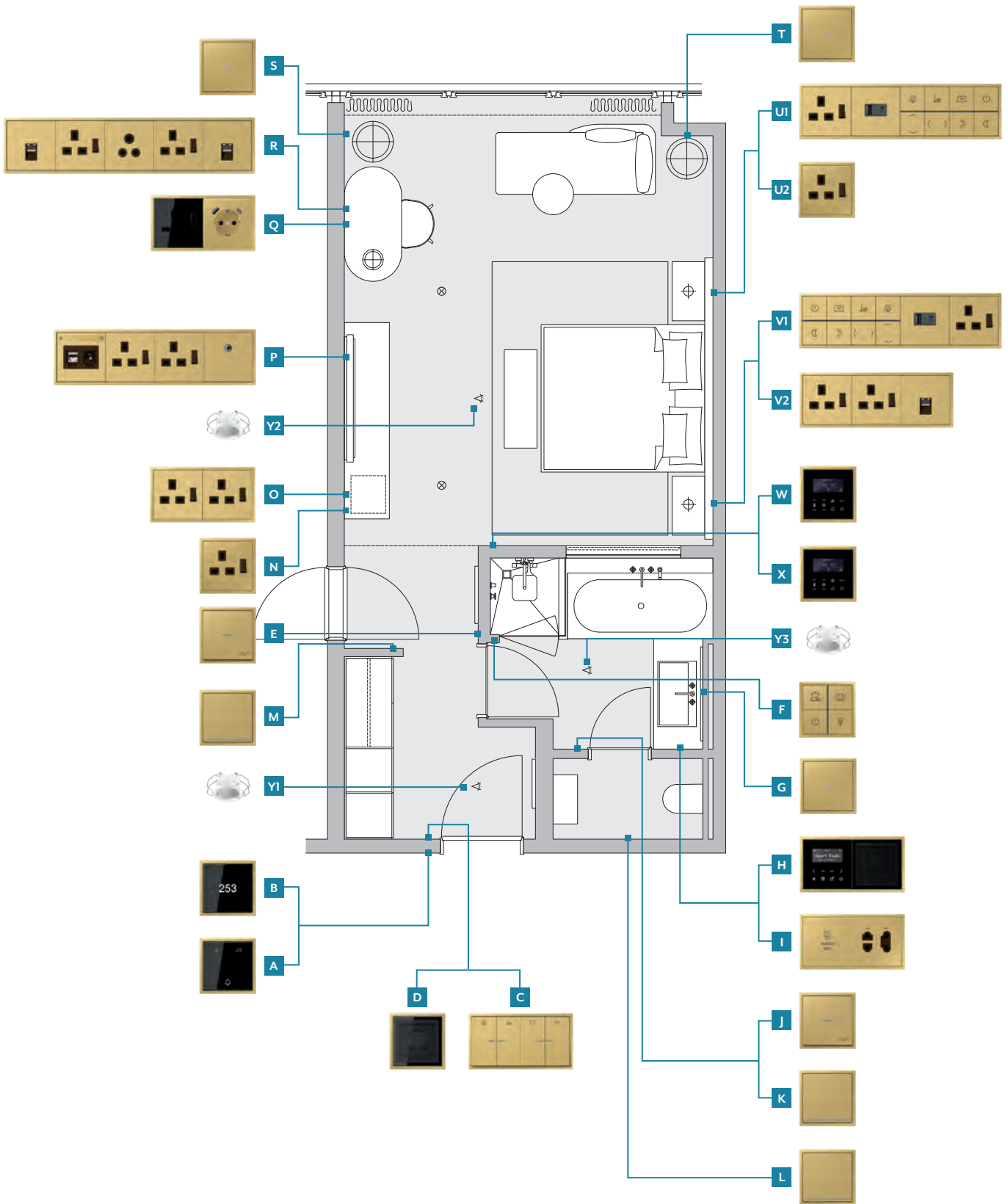

For a detailed view of the graphics, individual units are shown magnified here.

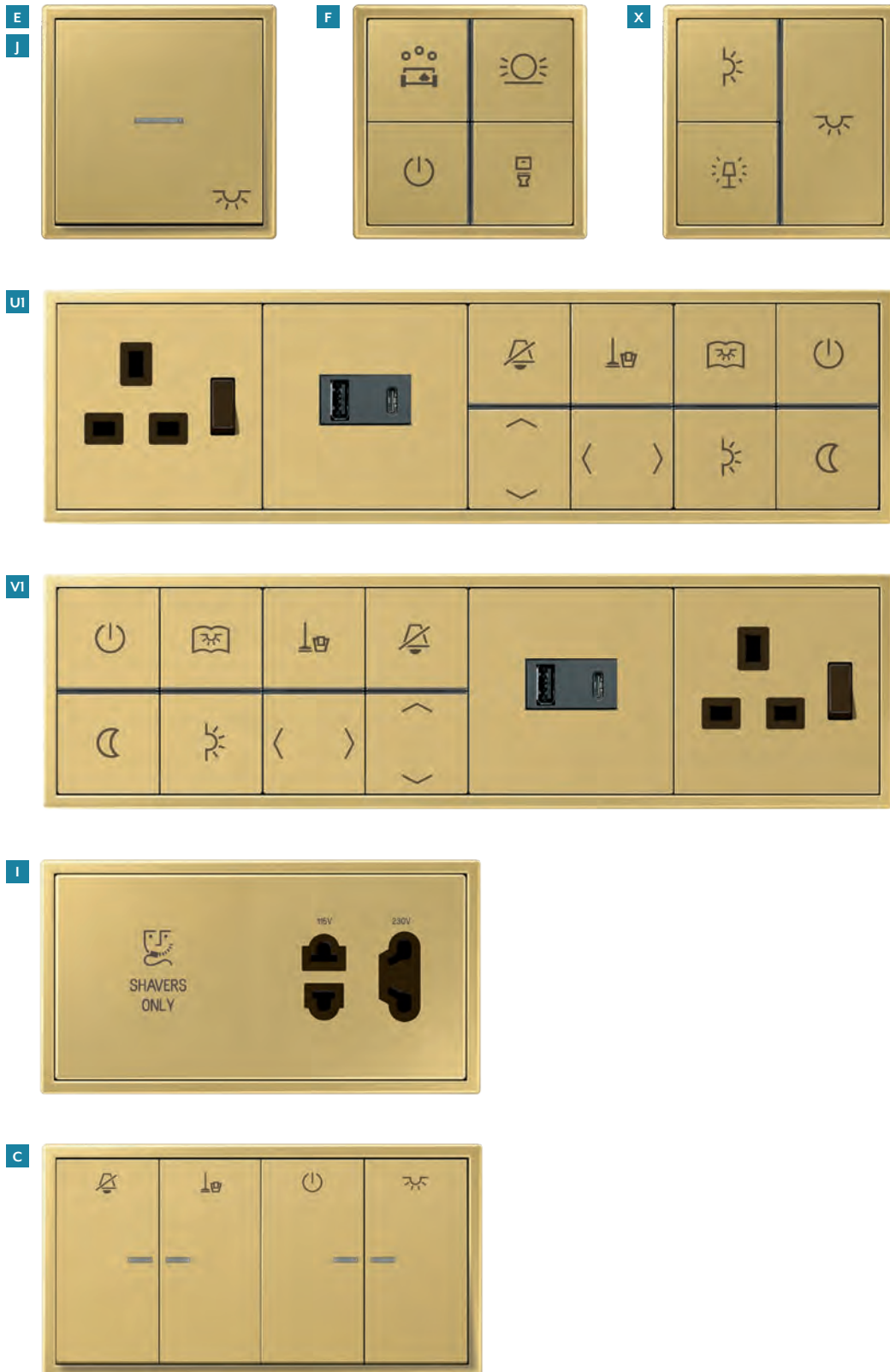

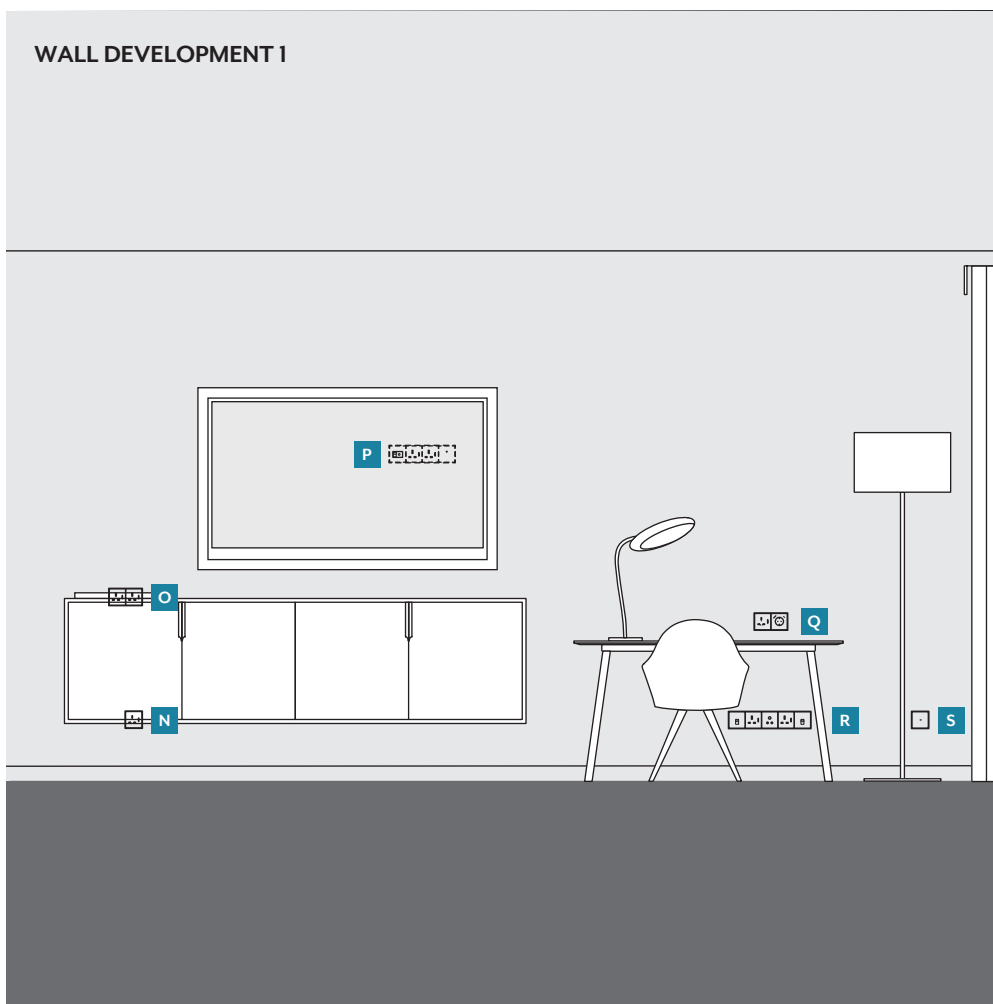

POS.	COMPONENTS	REF. NO.	QUANTITY
O	British Standard socket, switchable, LS range, classic brass	ME3171C	2
	2-gang frame, LS 990 range, classic brass	ME2982C	1
N	British Standard socket, switchable, LS range, classic brass	ME3171C	1
	1-gang frame, LS 990 range, classic brass	ME2981C	1
P	Smart TV wall box, LS range	MMDLS4521WW	1
	Cover with inscription field, LS range, classic brass	ME2969-2NVEC	1
	British Standard socket, switchable, LS range, classic brass	ME3171C	2
	Multimedia connection, 3.5 jack, LS range, classic brass	On request	1
Q	4-gang frame, LS 990 range, classic brass	ME2984C	1
	SCHUKO® socket with USB charger CA, LS range, classic brass	ME 1520-15 CA C-L	1
	Socket type G+I, LS range, black	LS4171 GI SW SW	1
R	2-gang frame, LS 990 range, classic brass	ME2982C	1
	IAE/UAE socket	UAE8UPO	1
	Cover IAE/UAE, LS range, classic brass	ME2969-IUAC	1
	British Standard socket, switchable, LS range, classic brass	ME3171C	1
	British Standard insert 5 A	3171-5EINS	1
	Cover British Standard, LS range, classic brass	BS2171-5MECPL	1
	British Standard socket, switchable, LS range, classic brass	ME3171C	1
	WLAN Access Point	WLAN-AC-UAE	1
	Cover WLAN Access Point, LS range, classic brass	ME2969-IUAC	1
	5-gang frame, LS 990 range, classic brass	ME2985C	1
S	Cable outlet with strain relief, LS range, classic brass	ME2990AC	1
	1-gang frame, LS 990 range, classic brass	ME2981C	1

## WALL DEVELOPMENT 2

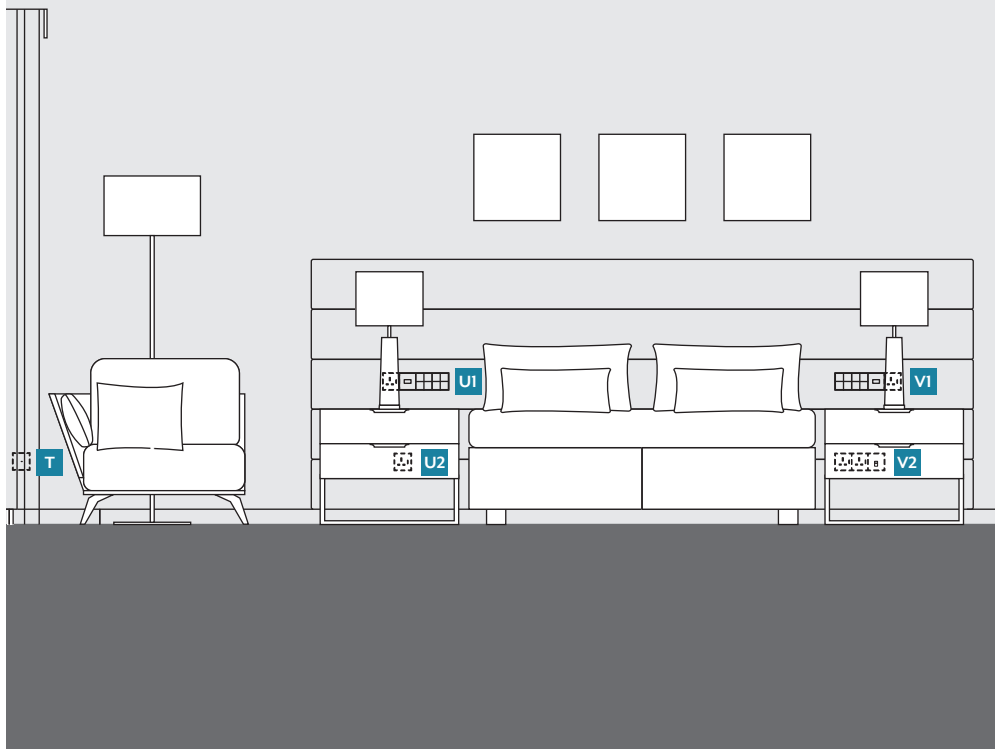

POS.	COMPONENTS	REF. NO.	QUANTITY
T	Cable outlet with strain relief, LS range, classic brass	ME2990AC	1
	1-gang frame, LS 990 range, classic brass	ME2981C	1
U1/V1	British Standard socket, switchable, LS range, classic brass	ME3171C	2
	USB charger, black	USB15CASW	2
	Cover USB charger, LS range, classic brass	ME1969USBC	2
	KNX push-button sensor F 40 Universal, 4-gang	4194TSM	2
	Cover kit, 4-gang, LS range, classic brass	ME2404TSAC	2
	KNX push-button sensor F 40 Universal, 4-gang	4194TSM	2
	Cover kit, 4-gang, LS range, classic brass	ME2404TSAC	2
	4-gang frame, LS 990 range, classic brass	ME2984C	2
U2	British Standard socket, switchable, LS range, classic brass	ME3171C	1
	1-gang frame, LS 990 range, classic brass	ME2981C	1
V2	British Standard socket, switchable, LS range, classic brass	ME3171C	2
	IAE/UAE socket	UAE8UPO	1
	Cover IAE/UAE, LS range, classic brass	ME2969-IUAC	1
	3-gang frame, LS 990 range, classic brass	ME2983C	1

## WALL DEVELOPMENT 3

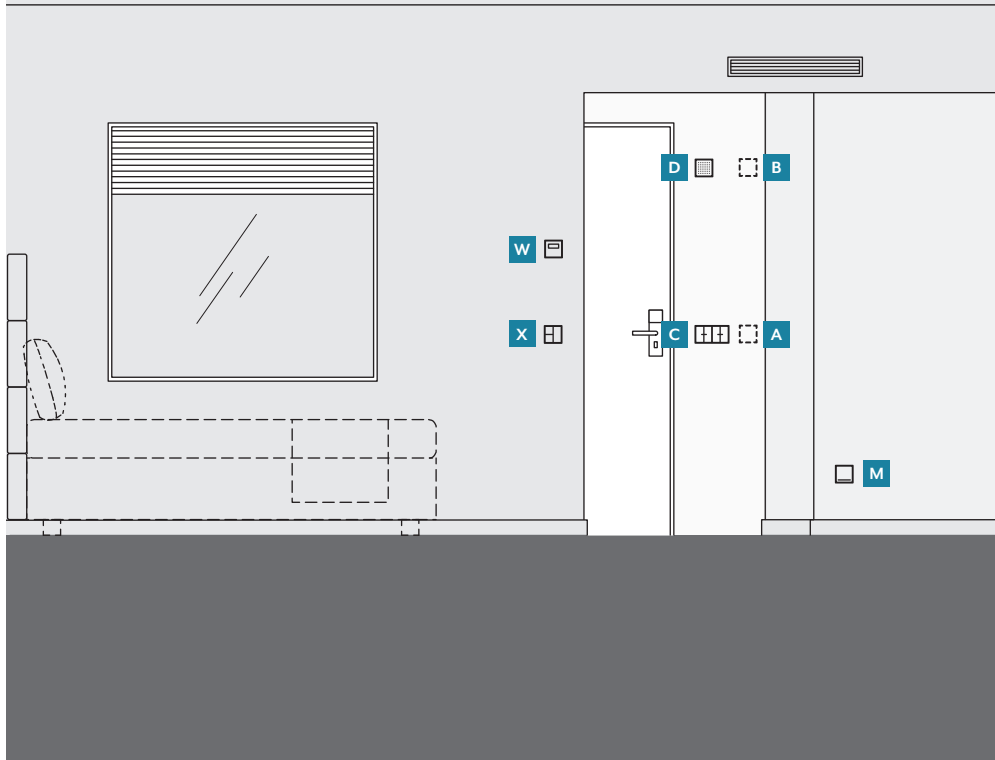

POS.	COMPONENTS	REF. NO.	QUANTITY
A	Hotel push-button insert, corridor unit, 1 pole NO contact, 230 V	53IKO5EUM230	1
	Hotel rocker, glass, corridor unit, LS range, black	LSCUKO6MSW	1
	1-gang frame, LS 990 range, classic brass	ME298IC	1
B	LED pilot light insert	LEDKO6TX24	1
	Glass cover, LS range, black	Labelling tool	1
	1-gang frame, LS 990 range, classic brass	ME298IC	1
C	KNX push-button Universal, 2-gang	LSCDI092IST	1
	Hotel rocker, room unit, LS range, classic brass	On request	1
	KNX push-button Standard, 1-gang	LSCDI07IIST	1
	Rocker with indicator light, LS range, classic brass	MEI0IKO5C	1
	2-gang frame, LS 990 range, classic brass	ME2982C	1
D	Triple-tone signal, classic brass	On request	1
	1-gang frame, LS 990 range, classic brass	ME298IC	1
M	LED pilot light, LS range, classic brass	MEI539-OOCLNW	1
	1-gang frame, LS 990 range, classic brass	ME298IC	1
W	KNX Temperature controller fan coil, LS range, black	TRDLS9248SW	1
	1-gang frame, LS 990 range, classic brass	ME298IC	1
X	KNX push-button sensor F 40 Universal, 3-gang	4I93TSM	1
	Cover kit, 3-gang, LS range, classic brass	ME2403TSAC	1
	1-gang frame, LS 990 range, classic brass	ME298IC	1



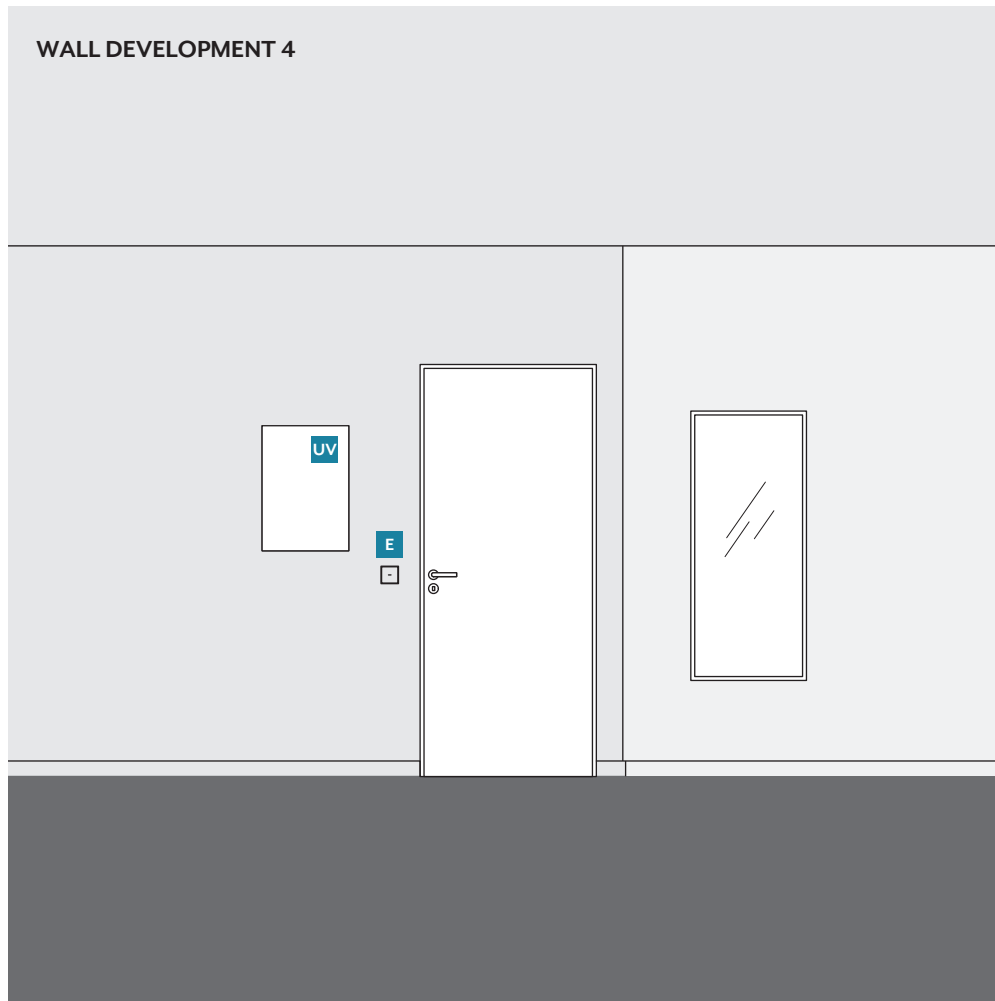

POS.	COMPONENTS	REF. NO.	QUANTITY
E	KNX push-button Standard, 1-gang	LSCDI0711ST	1
	Rocker with indicator light, LS range, classic brass	ME101KO5C	1
	1-gang frame, LS 990 range, classic brass	ME298IC	1

POS.	COMPONENTS	REF. NO.	QUANTITY
Distribution board	Power supply 24 V DC, for rail mounting	NT2415REGVDC	1
	KNX power supply with IP interface	20320ISIPSR	1
	KNX switch/blind actuator 24/12-gang	23024ISR	1
	KNX LED Universal dimming actuator, 2-gang	3902REGHE	1
	KNX 6-gang binary input	2116REG	1

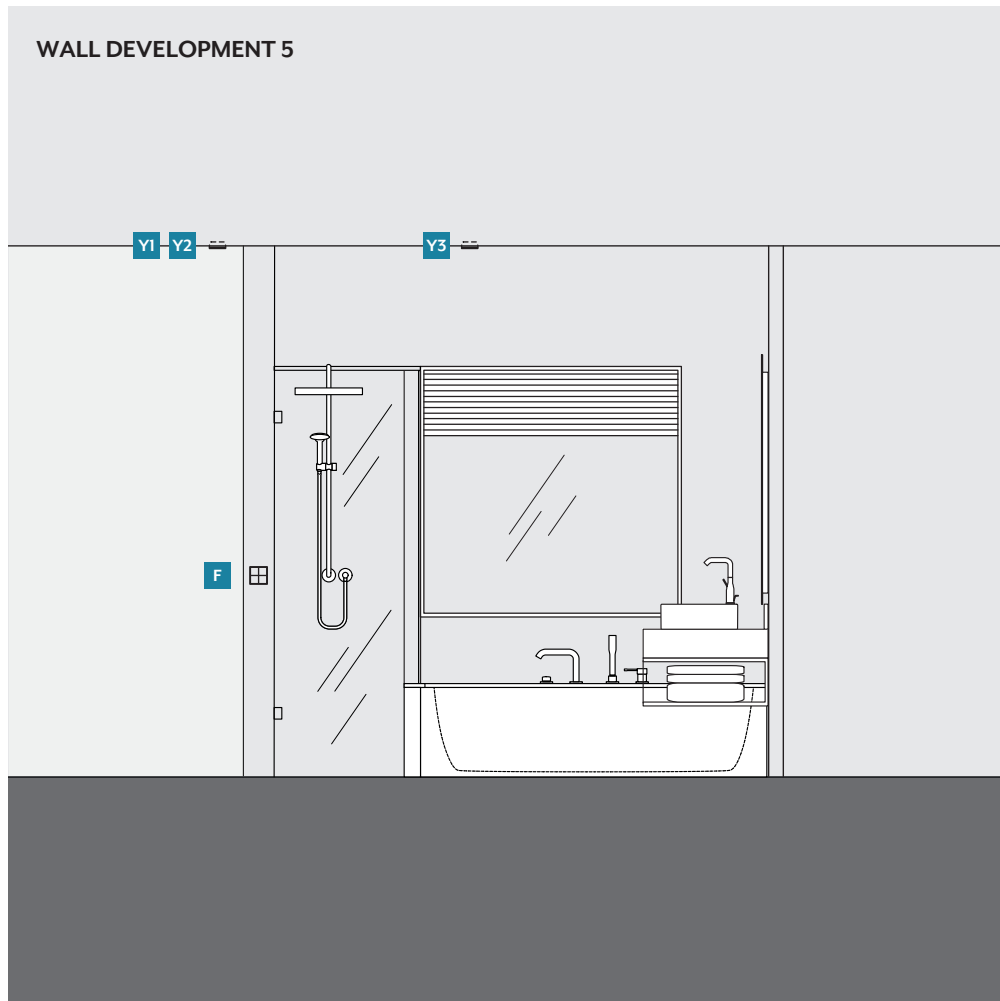

POS.	COMPONENTS	REF. NO.	QUANTITY
F	KNX push-button sensor F 40 Universal, 4-gang	4194TSM	1
	Cover kit, 4-gang, LS range, classic brass	ME2404TSAC	1
	1-gang frame, LS 990 range, classic brass	ME298IC	1

POS.	COMPONENTS	REF. NO.	QUANTITY
Y1-Y3	KNX presence detector mini	3361 M WW	3

## WALL DEVELOPMENT 6

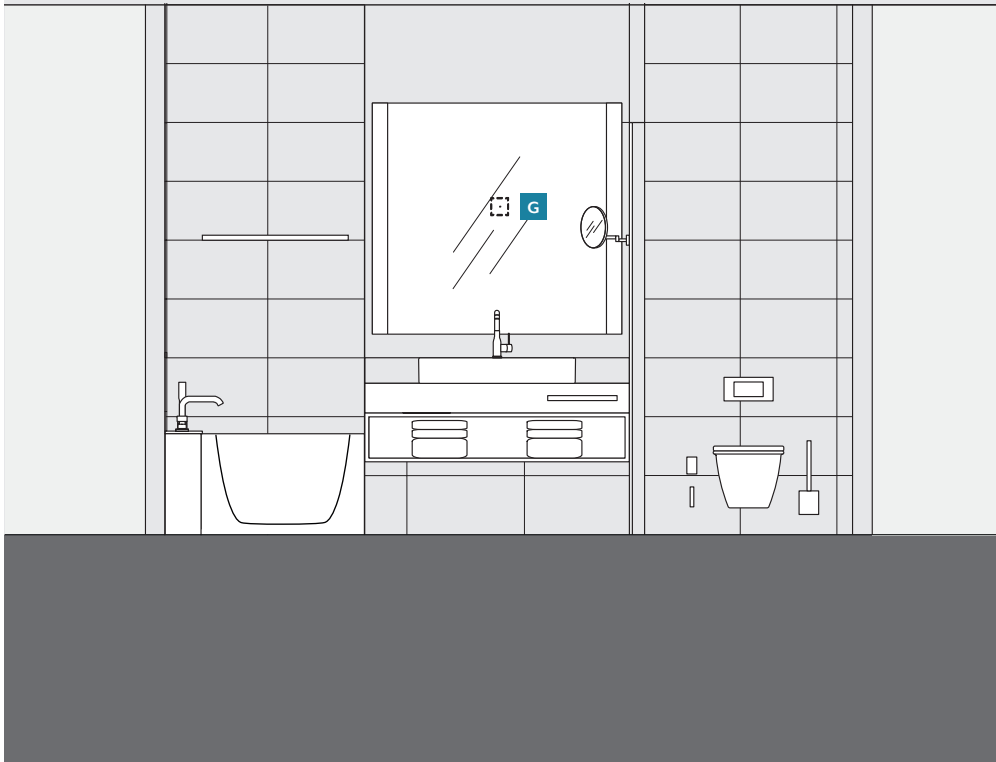

POS.	COMPONENTS	REF. NO.	QUANTITY
G	Cable outlet with strain relief, LS range	ME2990AC	1
	1-gang frame, LS 990 range, classic brass	ME2981C	1

## WALL DEVELOPMENT 7

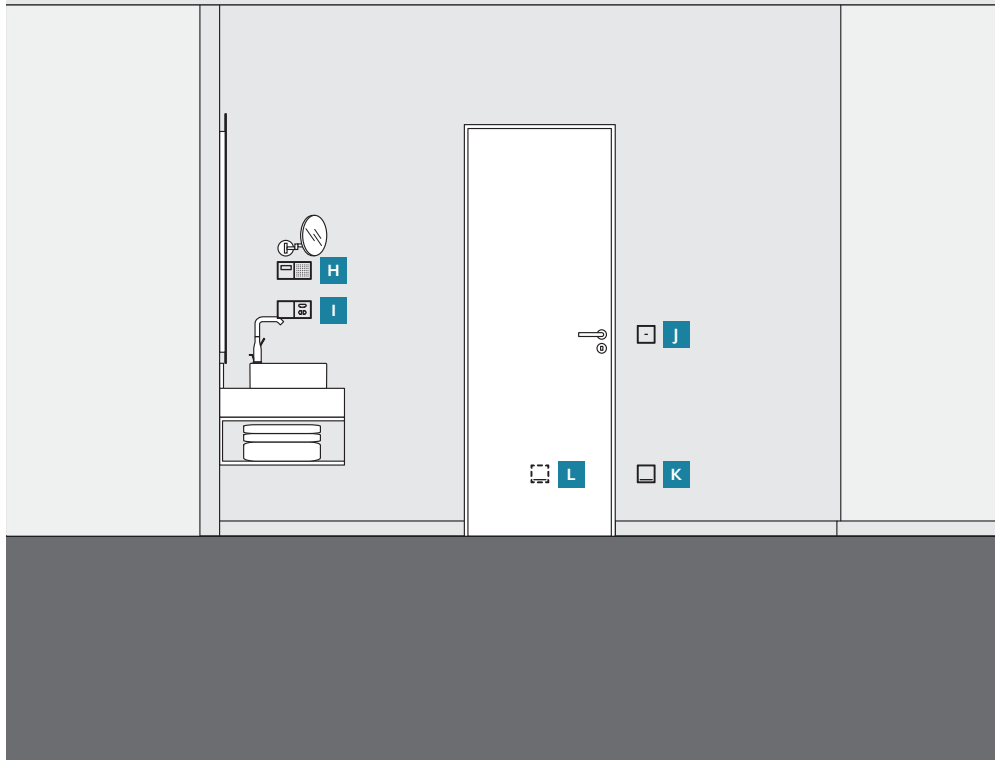

POS.	COMPONENTS	REF. NO.	QUANTITY
J	KNX push-button Standard, 1-gang	LSCD10711ST	1
	Rocker with indicator light, LS range, classic brass	ME101KO5C	1
	1-gang frame, LS 990 range, classic brass	ME2981C	1
H	Smart Radio DAB+ Bluetooth, mono LS range, black	DABLSIBTSW	1
	2-gang frame, LS 990 range, classic brass	ME2982C	1
I	Electric shaver socket outlet insert	SO7522EINS	1
	Cover electric shaver socket outlet, LS range, classic brass, horizontal	On request	1
	2-gang frame, LS 990 range, classic brass	ME2982C	1
K	LED pilot light, LS range, classic brass	ME1539-OOCLNW	1
	1-gang frame, LS 990 range, classic brass	ME2981C	1
L	LED pilot light, LS range, classic brass	ME1539-OOCLNW	1
	1-gang frame, LS 990 range, classic brass	ME2981C	1





### 3. OPERATION

#### 3.1 OPERATING PHILOSOPHY FOR SWITCHING, SENSING, DIMMING 72

3.1.1 Button assignment possibilities in KNX F 10 74

---

3.1.2 Button assignment possibilities in KNX F 40 75

---

3.1.3 Button assignment possibilities in KNX F 50 76

---

#### 3.2 VISU PRO HOTEL SOFTWARE 77

3.2.1 Reception 78

---

3.2.2 Housekeeping 79

---

#### 3.3 INTERFACES AND NETWORK 81

3.3.1 KNX 81

---

3.3.2 WLAN 82

---

## 3. Operation

Light, shading, room temperature as well as the display for the service personnel indicating whether a guest's room should be cleaned can be controlled simply and intuitively manually at the touch of a button from the hotel room or via the JUNG Visu Pro Hotel App.

### 3.1 Operating philosophy for switching, sensing, dimming

Combine various functions in the room sensibly into scenes, label with self-explanatory symbols and call up jointly at the press of a button: smart gain in comfort for the guest. Can be programmed individually according to the experience values of the owner.

#### The operating philosophy

	Conventional/ Electronic, 230 V	KNX	JUNG Bus	24 V
Rocker / push switch				
push-button, touch	●	●	–	●
dimmer				
Rotary dimmer (rotary sensor)	●	(●)	–	–
KNX push-button F 10	–	●	–	–
F 40	–	●	●	●
F 50	●	●	–	–



ROCKER SWITCHES



KNX PUSH-BUTTON F 40 , 4-GANG



KNX PUSH-BUTTON F 50, 2-GANG



ROTARY SENSOR



KNX PUSH-BUTTON F 10, 2-GANG

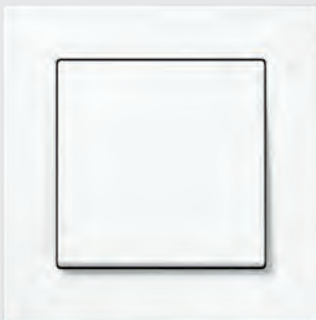

KNX PUSH-BUTTON F 10, 2-GANG



### 3.1.1 Button assignment possibilities in KNX F 10

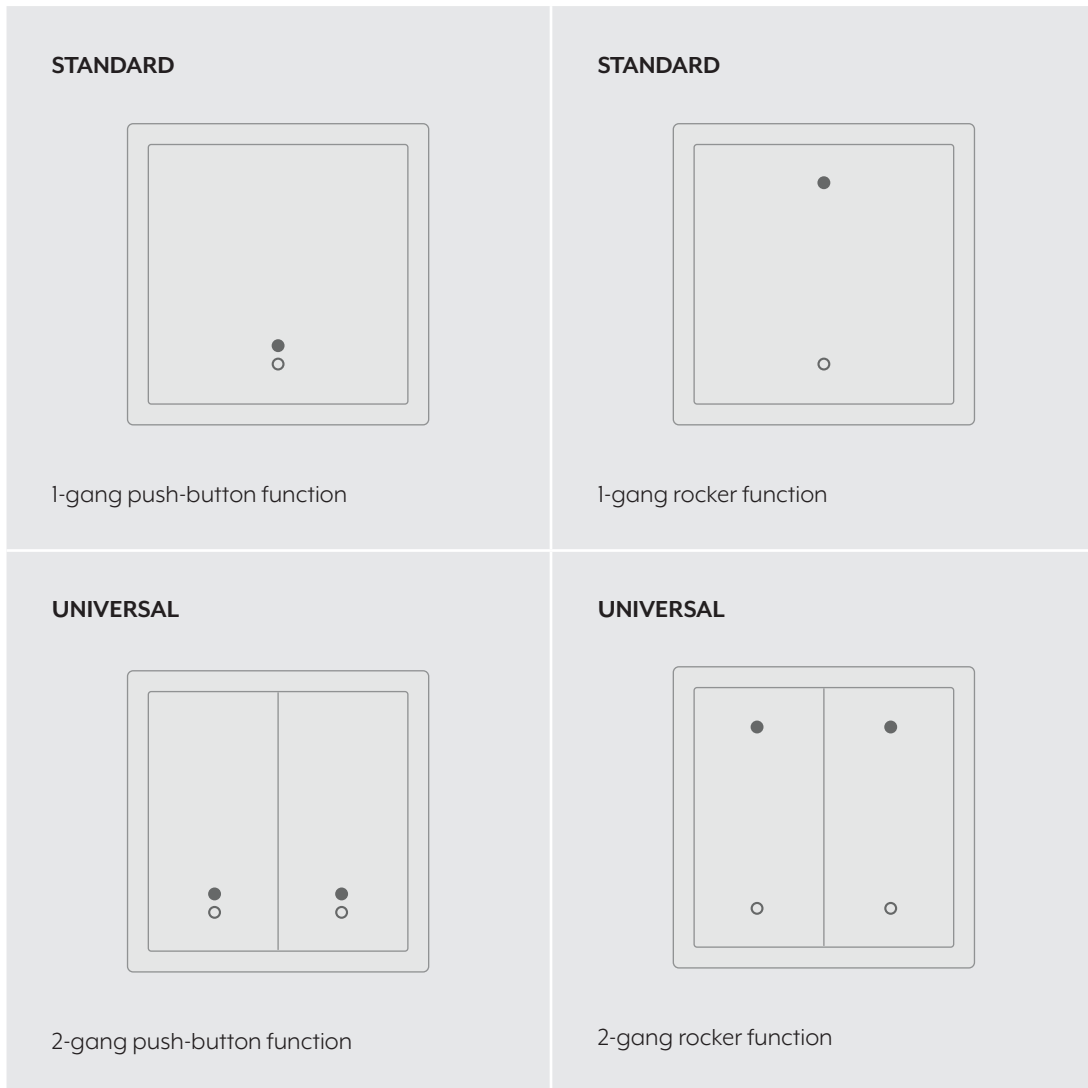

The KNX F 10 push-buttons master both the push-button function and the rocker function. The rocker function of the Standard version enables additional control possibilities compared to the push-button function, such as dimming lamps. Among other things, the push-button function in the Universal version enables full-surface operation. The KNX push-button F 10 thus combines numerous functions in an elegant design. And that completely encrypted: the KNX F 10 push-button communicates using KNX Data Secure if required. Thanks to trend-setting hardware architecture, the KNX F10 push-buttons can be updated without limit using the ETS Service app.

The button assignment of the new JUNG KNX F 10 push-buttons can be completely customised. The standard and universal push-buttons switch and dim lamps, control blinds and much more. In addition, their individual switching points can be assigned multiple times thanks to a sophisticated operating concept. In this way, they make particularly versatile control of the smart building possible.

### 3.1.2 Button assignment possibilities in KNX F 40

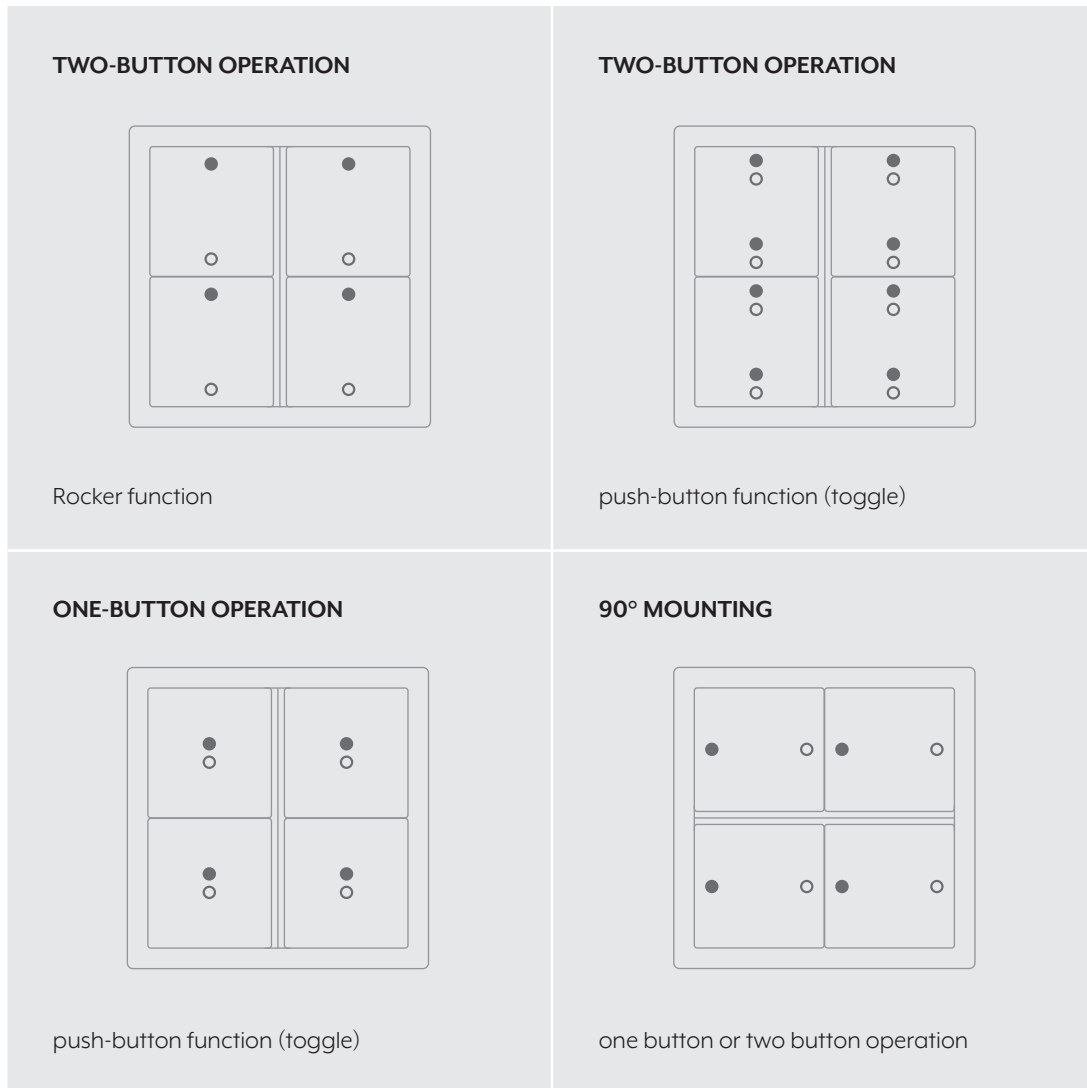

One button or two button operation can be set as operating modes for the F 40 push-button sensors. One operating button can be configured in each case as rocker or button function. For the rocker function, an operating button is divided into two operating pressure points with the same basic function. In contrast for the button function, an operating button is evaluated in two operating points with two individually parametrisable functions.

With regard to design and operating concept, the F 40 push-button sensors come close to a conventional switch. That makes the handling simple for the hotel guest. The large areas can be clearly marked using the Graphic Tool. By combining them with frames from the A, CD and LS ranges, the sensors match the rest of the hotel's design.

### 3.1.3 Button assignment possibilities in KNX F 50

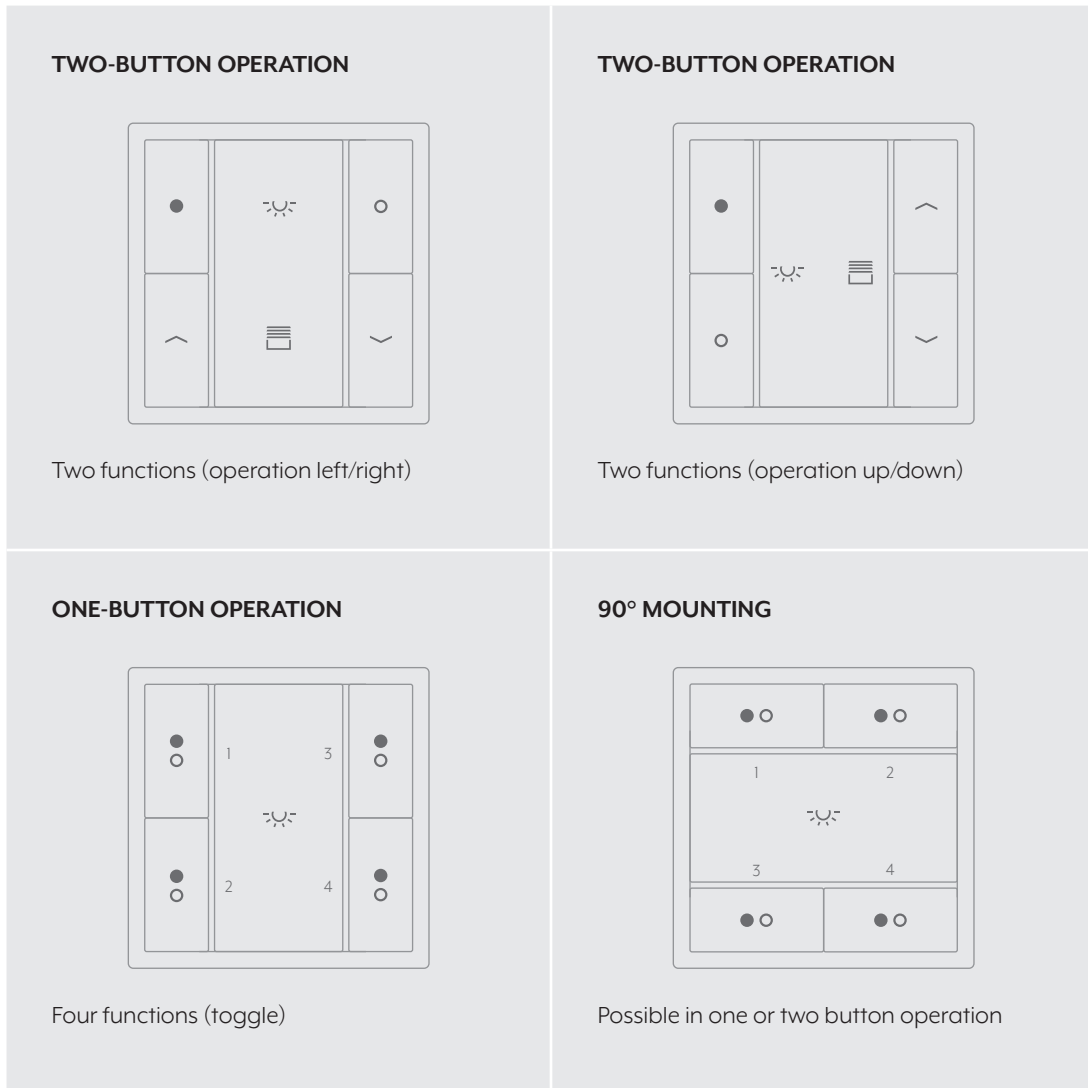

Two operating modes can be set for the F 50 push-button sensors: One-button operation and two-button operation. In the case of the two-button variant, the intuitively understandable operation can be optionally programmed for up/down or left/right. Horizontal mounting with appropriate button assignment can also be realised.

The push-button sensors F 50 can be individually labelled via the Graphic-Tool. This makes the operating options quickly comprehensible for the guest. Visually, the sensors blend perfectly into the design of the hotel by combining with the frames of the A/AS, CD and LS ranges.

## 3.2 Visu Pro Hotel software

The smart JUNG building technology supports efficient processing in the everyday hotel routine. The basis is the JUNG Visu Pro Hotel software, with which, for example, the building automation can be visualised and controlled, current bookings and occupancy of a room can be viewed or the housekeeping is shown on an app whether the personnel can go into a room and clean it or whether the guest currently does not want to be disturbed.



**ORACLE®**  
Hospitality

The front office works with well-known user interfaces; however hotel and control software behind this are connected with each other. Preset profiles are activated directly with the check-in. Wishes of the guest reach the personnel via notification on the monitor.

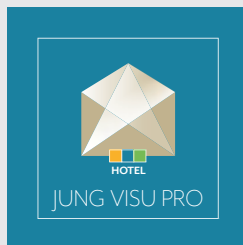

The core is the JUNG Visu Pro software with integrated interfaces to Protel and Micros Fidelio (Oracle). The hotel and control software are intelligently linked.

**ASSA ABLOY**

The link to the Visionline software is made via the interface in the JUNG Visu Pro software. Result: new benefits for owners and guests for automation and operating comfort.

JUNG Visu Pro Hotel has interfaces to the Protel and Oracle Hospitality systems. There is also an interface to Visionline available, the modern hotel locking system from Assa Abloy. In this way, hotel and control software are linked with each other intelligently.

The JUNG software enables you to connect up to 150 rooms with functions and processes with only one licence. Licences can be operated in parallel for larger systems. Linking these processes supports an efficient workflow. For example, housekeeping can use the app to see which rooms have already been cleaned and document completed cleaning in real time.

### 3.2.1 Reception

Optimised processes at the reception – satisfied guests:  
intelligently link hotel and control software for efficient time management and the best service.

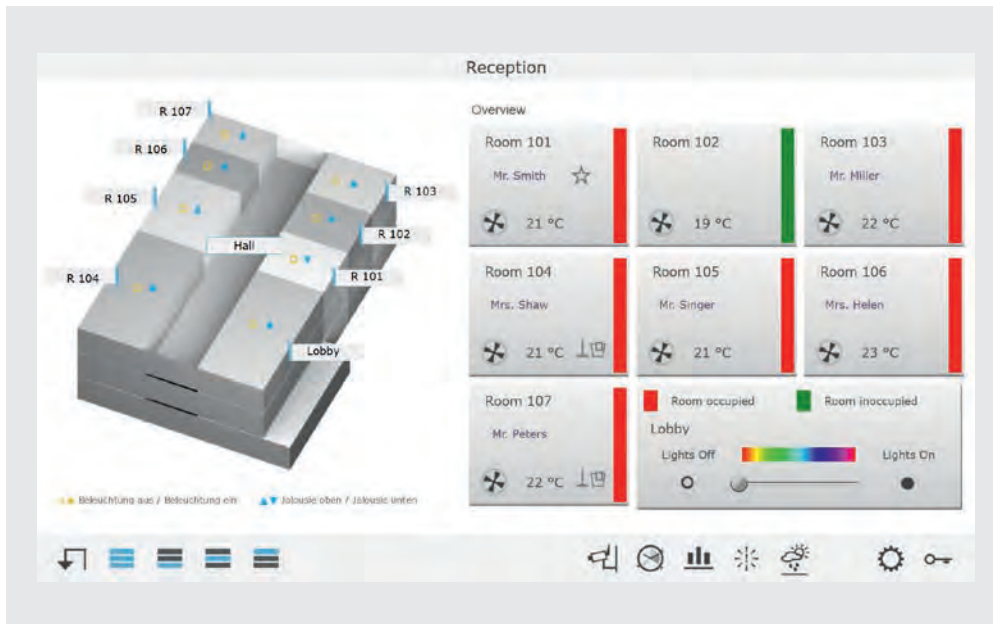

Personnel at the reception can view information about each room for each floor. This information includes the status of the room (room occupied; room not occupied), which is represented by a green or red bar respectively. In addition, the name of the guest is displayed for each room, as well as the room temperature.

In addition, the general overview of the individual floor shows for each room whether the light is on or off and whether the blinds are raised or lowered. Every change is shown on the display in real time.

### 3.2.2 Housekeeping

Structured and well-coordinated work processes are also extremely important for the housekeeping. Smart JUNG building technology supports the efficient processing here in the everyday hotel routine. For motivated employees and satisfied guests.



The app visualisation for housekeeping displays the occupancy status for each room. The guest's wishes, e.g. whether cleaning or do not disturb is desired, are displayed there. This is indicated by a symbol with a red or green background. Red means that the guest does not want to be disturbed at the moment and that the room should therefore be cleaned at another time. Green indicates to the personnel that the room should be cleaned.

It also indicates to housekeeping when the room was last cleaned. Below this display is another button that housekeeping taps when the room cleaning has been completed. After the button has been tapped, the date of the last cleaning of the room is set to the current date.

### KNX – FACTS AND FIGURES

1990

Over 30 years on the market



94,398 partners in  
171 countries



500 manufacturers in  
45 countries



500 training centres in  
72 countries

DATE: NOVEMBER 2020



## 3.3 Interfaces and network

### 3.3.1 KNX

Many modern hotels rely on KNX because the smart bus system is the only worldwide uniform standard for future-proof building technology. The KNX technology enables central and individual linking and control of the individual modules. Thus, owners and investors, architects, planners and electrical installers have long-term security. As a founding member of the KNX Association, JUNG has supported this highly intelligent technology from the beginning.

From the easy to use control element to the complex system, the JUNG KNX components provide comprehensive, future-proof solutions for control, visualisation and organisation of the building system technology. Areas such as lighting, shade, heating / air conditioning, surveillance / security and multimedia are completely covered here.

After a long day, come into the hotel room and switch off immediately. To do so, the KNX system from JUNG takes over everything else: your preferred temperature, the ideal lighting mood and good entertainment. We try to make your stay as pleasant and as simple as possible.

Further information about the subject of KNX can be found in chapter "14 KNX" starting on page 84.



The most intelligent worldwide standard for the modern building. From the easy to use control element to the complex system, the JUNG KNX components provide comprehensive, future-proof solutions for control, visualisation and organisation of the building system technology. Areas such as lighting, shade, heating / air conditioning, surveillance / security and multimedia are completely covered here.

### 3.3.2 WLAN

The best WLAN reception in a hotel should be a matter of course today. To ensure this, there is a simple solution, the WLAN Access Point PoE in JUNG design.

Fast, trouble-free access to the Internet is essential for most guests today. In order to really guarantee continuous reception quality everywhere, existing network sockets, for example, can be replaced with the WLAN Access Points PoE in JUNG design without great effort. The then resulting particularly powerful radio cells provide maximum wireless bandwidth. Once installed in the wall, the WLAN range can be adapted to the conditions of the hotel as required. The resulting high-performance room wireless cells provide maximum wireless bandwidth in the hotel. The best reception is thus always ensured.

Thanks to its design in the JUNG switch design, the WLAN Access Point PoE blends in harmoniously with the rest of the electrical installation in the hotel. This also makes it ideal for retrofitting; existing network sockets can be easily replaced with the elegant device.

#### WLAN ACCESS POINT POE WLAN-AC-UAE

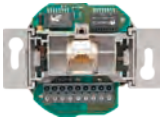

DESCRIPTION	COVER IN RANGE	REFERENCE NUMBER
<ul style="list-style-type: none"> <li>▪ Power supply via PoE (class 3)</li> </ul>	AS / A	A 569-1 .. PLUA ..
<ul style="list-style-type: none"> <li>▪ Operation as WLAN Access Point, Client, Repeater, Bridge</li> </ul>	CD	CD 569-1 UA ..., CD 569-1 NAUA ..
<ul style="list-style-type: none"> <li>▪ Screw terminals at the back (9-pole) for LAN cable</li> </ul>	SL	SL 569-1 UA ..
<ul style="list-style-type: none"> <li>▪ LAN connection on the front via RJ45 socket</li> </ul>	LS	.. 969-1 UA ..., ... 969-1 NAUA ..
<ul style="list-style-type: none"> <li>▪ In addition, PoE is provided at the front socket (class 2)</li> </ul>	50 x 50	169-1 UAE WW
<ul style="list-style-type: none"> <li>▪ Integrated WLAN antenna</li> <li>▪ WLAN can be switched off via timer and time switch function</li> <li>▪ WLAN range can be adjusted</li> <li>▪ Settings via integrated web server</li> <li>▪ Mounting in device box according to DIN 49073</li> <li>▪ Not suitable for installation in surface caps</li> </ul>		





## 4. INTERNATIONAL SOCKETS

### 4.1 FUSED CABLE UNIT 87

### 4.2 OVERVIEW OF INTERNATIONAL SOCKETS 88



# 4. International sockets

The worldwide market is covered by JUNG with international sockets. These are available in various materials, colours and product ranges. This means that the international sockets can be selected from the diverse JUNG design in accordance with the other electrical installations. A globally operating hotel chain can thus rely on recognition value down to the last detail.

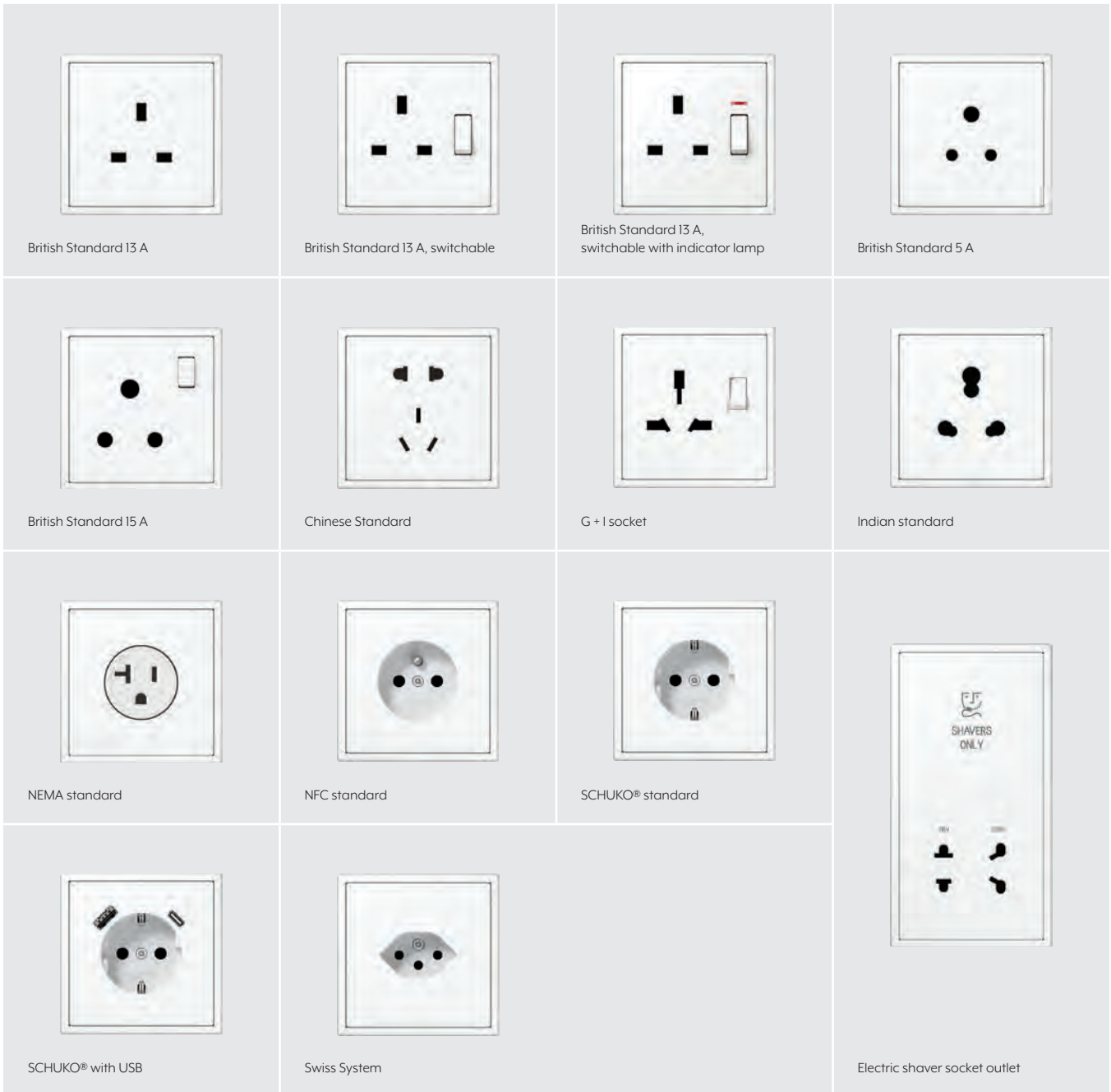

## 4.1 Fused Cable Unit

The Fused Cable Unit replaces the use of sockets and plugs. For example, floor lamps or desk lighting can be connected directly to the insert and switched on the wall. The 3190 CU KO EINS insert is installed in a BS 6042 flush-mounted box.

The insert BS 2190 CU KO EINS is mounted in wall boxes according to DIN 49073 and allows the combination of different inserts next to each other.

The cover for the switching cable unit order no. BS 2190 CU KO EINS is only possible in combination with frame BS 2181. The cover for the switching cable unit order no. BS 3190 CU KO EINS is only possible in combination with frames in the LS range.

### FUSED CABLE UNIT

BS 2190 CU KO EINS / 3190 CU KO EINS



#### CONNECTION AND FUNCTIONS

Voltage	250 V ~
Current	13 A
Connection	Screw terminals for rigid and flexible cores up to 4 mm <sup>2</sup>
Number of poles / earth cable	2-pole
increased contact protection	no

#### THERMOPLASTIC (breakproof) glossy

#### for frames in the BS range 2181..

#### for frames in the LS range

ivory	BS 2190 CU KO PL	A 3190 CU KO PL
white	BS 2190 CU KO WW PL	A 3190 CU KO WW PL
black	BS 2190 CU KO SW PL	A 3190 CU KO SW PL
champagne	–	A 3190 CU KO CH PL
mocha	–	A 3190 CU KO MO PL

#### METAL VERSIONS

aluminium	BS 2190 CU KO AL PL	A 3190 CU KO AL PL
anthracite (lacquered aluminium)	BS 2190 CU KO AN PL	–
dark (lacquered aluminium)	BS 2190 CU KO ALD PL	–
stainless steel	BS 2190 CU KO ES PL	–
chrome	BS 2190 CU KO GCR PL	–
golden	BS 2190 CU KO GO PL	–
classic brass	BS 2190 CU KO MEC PL	–
antique brass	BS 2190 CU KO MEAT PL	–

## 4.2 Overview of international sockets

### BRITISH STANDARD 13 A



suitable for socket insert 3521 EINS  
British Standard 1363

### BRITISH STANDARD 13 A

switchable without indicator lamp



suitable for socket insert 3171 EINS  
British Standard 1363

#### CONNECTION AND FUNCTIONS

Voltage	250 V ~			
Current	13 A			
Connection	Screw terminals for rigid and flexible cores up to 4 mm <sup>2</sup> according to BS 1363-1			
Number of poles / earth cable	2-pole + earth		2-pole + earth; with switch	
increased contact protection	yes			
Insert	3521 EINS BS 1363	3521 EINS BS 1363	3171 EINS BS 1363	3171 EINS BS 1363

DUROPLASTIC (scratch-proof), glossy	LS range	A / AS range	LS range	A / AS range
ivory	BS 2521 PL	A 3521 PL	BS 2171 PL	A 3171 PL
white	BS 2521 WW PL	A 3521 WW PL	BS 2171 WW PL	A 3171 WW PL
black	BS 2521 SW PL	A 3521 SW PL	BS 2171 SW PL	A 3171 SW PL

DUROPLASTIC lacquered				
aluminium	–	A 3521 AL PL	–	A 3171 AL PL
champagne	–	A 3521 CH PL	–	A 3171 CH PL
mocha	–	A 3521 MO PL	–	A 3171 MO PL

METAL VERSIONS				
aluminium	BS 2521 AL PL	–	BS 2171 AL PL	<b>Thermoplastic</b> (breakproof)
stainless steel	BS 2521 ES PL	–	BS 2171 ES PL	
anthracite (lacquered aluminium)	BS 2521 AN PL	–	BS 2171 AN PL	high-gloss ivory A 3171 BF WW PL black A 3171 BF SW PL
dark (lacquered aluminium)	BS 2521 ALD PL	–		
chrome	BS 2521 GCR PL	–	BS 2171 GCR PL	
golden	BS 2521 GO PL	–	BS 2171 GO PL	<b>Thermoplastic</b> (breakproof) lacquered
classic brass	BS 2521 MEC PL	–	BS 2171 MEC PL	
antique brass	BS 2521 MEAT PL	–	BS 2171 MEAT PL	matt anthracite A 3171 BF ANM PL



**BRITISH STANDARD 13 A**

switchable with indicator lamp

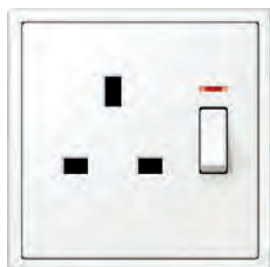
suitable for socket insert 3171 KO EINS  
British Standard 1363**BRITISH STANDARD 5 A**

switchable without indicator lamp

suitable for socket insert 3171-5 EINS  
British Standard 546**CONNECTION AND FUNCTIONS**

Voltage	250 V ~			
Current	13 A		5 A	
Connection	Screw terminals for rigid and flexible cores up to 4 mm <sup>2</sup> according to BS 1363-1		Screw terminals for rigid and flexible cores up to 4 mm <sup>2</sup> according to BS 546	
Number of poles / earth cable	2-pole + earth; with switch 2-pole		2-pole + earth	
increased contact protection	yes			
Insert	3171 KO EINS BS 1363	3171 KO EINS BS 1363	3171-5 EINS BS 546	3171-5 EINS BS 546

<b>DUROPLASTIC</b> (scratch-proof), glossy	<b>LS range</b>	<b>A / AS range</b>	<b>LS range</b>	<b>A / AS range</b>
ivory	BS 2171 KO PL	A 3171 KO PL	BS 2171-5 PL	A 3171-5 PL
white	BS 2171 KO WW PL	A 3171 KO WW PL	BS 2171-5 WW PL	A 3171-5 WW PL
black	BS 2171 KO SW PL	A 3171 KO SW PL	BS 2171-5 SW PL	A 3171-5 SW PL

<b>DUROPLASTIC</b> lacquered				
aluminium	–	A 3171 KO AL PL	–	A 3171-5 AL PL
champagne	–	A 3171 KO CH PL	–	A 3171-5 CH PL
mocha	–	A 3171 KO MO PL	–	A 3171-5 MO PL

<b>METAL VERSIONS</b>				
aluminium	BS 2171 KO AL PL	<b>Thermoplastic</b> (breakproof) high-gloss white A 3171 BF KO WW PL black A 3171 BF KO SW PL	BS 2171-5 AL PL	<b>Thermoplastic</b> (breakproof) high-gloss white A 3171-5 BF WW PL
stainless steel	BS 2171 KO ES PL		BS 2171-5 ES PL	
anthracite (lacquered aluminium)	BS 2171 KO AN PL		BS 2171-5 AN PL	
dark (lacquered aluminium)	–	A 3171 BF KO SW PL	–	
chrome	BS 2171 KO GCR PL		BS 2171-5 GCR PL	
golden	BS 2171 KO GO PL	<b>Thermoplastic</b> (breakproof) lacquered matt anthracite A 3171 BF KO ANM PL	BS 2171-5 GO PL	<b>Thermoplastic</b> (breakproof) lacquered matt anthracite A 3171-5 BF ANM PL
classic brass	BS 2171 KO MEC PL		BS 2171-5 MEC PL	
antique brass	BS 2171 KO MEAT PL		BS 2171-5 MEAT PL	

## BRITISH STANDARD 15 A



suitable for socket insert 2171-15

## CHINESE STANDARD



with socket insert 3521-5 CN EINS

## CONNECTION AND FUNCTIONS

Voltage	250 V ~	
Current	15 A	10 A
Connection	Screw terminals for rigid and flexible cores up to 4 mm <sup>2</sup>	
Number of poles / earth cable	2-pole + earth; with switch 2-pole	2-pole without earth for flat and round pins; 2-pole + earth, only flat pins
increased contact protection	yes	
Insert	BS 2171-15 EINS	3521-5 CN EINS

## DUROPLASTIC

(scratch-proof), glossy

## LS range

## LS range

ivory	BS 2971-15 V PL	LS 3521-5 CN PL
white	BS 2971-15 V WW PL	LS 3521-5 CN WW PL
black	BS 2971-15 V SW PL	LS 3521-5 CN SW PL

## DUROPLASTIC lacquered

aluminium	Special lacquering of the cover (duroplastic, scratch-proof, glossy) possible on request.
champagne	
mocha	

## METAL VERSIONS

aluminium	Applies to all colours listed on the left except chrome, classic brass and antique brass.	AL 3521-5 CN PL
stainless steel		ES 3521-5 CN PL
chrome		GCR 3521-5 CN PL
anthracite (lacquered aluminium)	The golden version is only available as a real metal version and is not lacquered.	AL 3521-5 CN AN PL
dark (lacquered aluminium)		AL 3521-5 CN D PL
golden		GO 3521-5 CN PL
classic brass		ME 3521-5 CN C PL
antique brass		ME 3521-5 CN AT PL

## SWITCHABLE SOCKET, TYPE G + I

## INDIAN STANDARD



for plug BS 1363 (type G),  
GB 2099-1 (type I)



with socket insert 521 IN-EINS

## CONNECTION AND FUNCTIONS

Voltage	250 V ~	
Current	13 A	16 A
Connection	Screw terminals for rigid and flexible cores up to 4 mm <sup>2</sup> according to BS 1363-1	
Number of poles / earth cable	2-pole + earth; with switch	2-pole + earth
increased contact protection	yes	
Insert	4171 GI SW EINS	521 IN-EINS

## DUROPLASTIC

(scratch-proof), glossy

## LS range

ivory	LS 4171 GI SW PL
white	LS 4171 GI SW WW PL
black	LS 4171 GI SW SW PL

## LS and A/AS ranges

LS / A 521 IN PL
LS / A 521 IN WW PL
A 521 IN SW PL

## DUROPLASTIC lacquered

aluminium
champagne
mocha

## A range

(see Export catalogue for further versions in thermoplastic)

A 521 IN AL PL
A 521 IN CH PL
A 521 IN MO PL

## METAL VERSIONS

aluminium
stainless steel
chrome
anthracite (lacquered aluminium)
dark (lacquered aluminium)
golden
classic brass
antique brass

## LS range

AL 2521 IN PL
ES 2521 IN PL
—
AL 2521 IN AN PL
—
GO 2521 ON PL
ME 2521 IN C PL
ME 2521 IN AT PL

## NEMA STANDARD



## FRENCH/BELGIAN SYSTEM

(with screw terminals NFC standard)



## CONNECTION AND FUNCTIONS

Voltage	125 V~; 5-15 R or 5-20 R	250 V ~
Current	15 A or 20 A	16 A
Connection	Screw terminals for rigid and flexible cores up to 4 mm <sup>2</sup> according to USA NEMA standard	Spring terminals for rigid and untreated flexible cores up to 2.5 mm <sup>2</sup> ; version with screw terminals on request = NFC
Number of poles / earth cable		2-pole + earth
increased contact protection		yes
Insert	–	1520 F EINS and 1521 F EINS

## THERMOPLASTIC

(breakproof) high-gloss

## LS and A / AS and CD ranges

## LS and A /AS and CD ranges SL range

ivory	A / CD 521-15 /-20	LS / A / CD 1520 FK I	SL 521 FK I WW
white	LS / A / CD 521-15 /-20 WW	LS / A / CD 1520 FK I WW	
black	A / CD 521-15 /-20 SW	LS / A 1520 FK I SW	SL 521 FK I SW
gold-bronze	–	–	SL 521 FK I GB
light grey	–	LS 1520 FK I LG	

## THERMOPLASTIC

(breakproof) high-gloss

## LS / A / AS and CD ranges

## A range

aluminium		A 1520 FK I AL	(for other versions in thermo-plastic, see General catalogue; for other colours in the CD series see Export catalogue)
champagne	aluminium, black plug insert A / CD 521-15 /-20 AL	A 1520 FK I CH	
mocha		A 1520 FK I MO	
mat anthracite	–	–	

## METAL VERSIONS

## LS range (with black plug insert)

## LS range

aluminium	AL 2521-15 /-20	AL 1520 FK I
stainless steel	ES 2521-15 /-20	ES 1520 FK I
classic brass	ME 2521-15 /-20 C	ME 1520 FK I C
antique brass	ME 2521-15 /-20 AT	ME 1520 FK I AT
anthracite (lacquered aluminium)	–	AL 1520 FK I AN
dark (lacquered aluminium)	–	AL 1520 FK I D

## SCHUKO® STANDARD

## SCHUKO® SOCKET WITH USB



## CONNECTION AND FUNCTIONS

Voltage	250 V ~	
Current	16 A	
Connection	Screw terminals for rigid and flexible cores up to 2.5 mm <sup>2</sup> (.. 1520 ..)	Screw terminals for rigid and flexible cores up to 2.5 mm <sup>2</sup>
	Variant with screw terminals available (.. 1521 ..)	
Number of poles / earth cable		
increased contact protection	possible	
Insert	.. 1520 .. and .. 1521 ..	.. 1520-15CA ..

## THERMOPLASTIC

(breakproof) high-gloss

		LS range	A range
ivory	The SCHUKO® sockets are available in the A/AS, CD, SL and LS ranges in a variety of materials and colours.	LS 1520-15CA	A 1520-15CA
white		LS 1520-15CA WW	A 1520-15CA WW
black	Screw fixing is also possible.	LS 1520-15CA SW	A 1520-15CA SW
gold-bronze	For more details, please see the JUNG General Catalogue.	–	–
light grey		LS 1520-15CA LG	

## THERMOPLASTIC

(breakproof) high-gloss

aluminium		–	A 1520-15CA AL
champagne		–	A 1520-15CA CH
mocha		–	A 1520-15CA MO
matt anthracite	–	–	A 1520-15CA ANM

## METAL VERSIONS

		LS range	
aluminium		AL 1520-15CA-L	–
stainless steel		ES 1520-15CA-L	–
classic brass		ME 1520-15C A C-L	–
antique brass		ME 1520-15CA AT-L	–
anthracite (lacquered aluminium)		AL 1520-15CA AN-L	–
dark (lacquered aluminium)		AL 1520-15CA D-L	–

## SWISS SYSTEM TYPE 13

## SHAVER SOCKET



with socket insert SO 7522 EINS

## CONNECTION AND FUNCTIONS

Voltage	250 V ~	Input: 230 V~; output 115 V~ and 230 V~
Current	10 A	20 V A
Connection	Spring terminals for rigid conductors up to 2.5 mm <sup>2</sup>	Screw terminals for rigid and flexible cores up to 4 mm <sup>2</sup>
Number of poles / earth cable	2-pole + earth	2-pole + earth
increased contact protection	no	yes

## DUROPLASTIC

(scratch-proof), glossy

## LS range

(see Export catalogue for A/AS range)

## LS range

(see Export catalogue for A/AS range)

ivory	LS 1520-13 SEV	SO LS 7522 PL
white	LS 1520-13 SEV WW	SO LS 7522 WW PL
black	LS 1520-13 SEV SW	SO LS 7522 SW PL
light grey	LS 1520-13 SEV LG	SO LS 7522 LG PL S

## DUROPLASTIC lacquered

**LS range** available in 15 colours  
Les Couleurs® Le Corbusier  
(see also Export catalogue)

## METAL VERSIONS

## LS range

## LS range

aluminium	AL 1520-13 SEV	SO AL 7522 PL
stainless steel	ES 1520-13 SEV	SO ES 7522 PL
anthracite (lacquered aluminium)	AL 1520-13 SEV AN	SO AN 7522 PL
dark (lacquered aluminium)	–	SO AL 7522 D PL
chrome	–	SO GCR 7522 PL
golden	–	SO GO 7522 PL
classic brass	–	SO ME 7522 C PL
antique brass	–	SO ME 7522 AT PL







**5. CARD READER****5.1 COVERS 98****5.2 INSTALLATION 99**

## 5. Card reader

A modern hotel relies on practical key cards. Each key card only unlocks the hotel room door assigned to it. To do this, simply hold the card in front of the card reader in the corridor.

The integration of card readers from the different door lock system manufacturers into the JUNG system can be tested and implemented in the project.

### 5.1 Covers

JUNG provides a platform that makes it possible to integrate the card readers of access controls into the JUNG design on a project-specific basis. The 1-gang / 2-gang card reader covers and 1-gang / 2-gang glass card reader covers are available to match the other JUNG covers.

The required support elements for adaptation are matched to the readers used and the wall boxes in the specific project. The new adaptation concept allows more installation space within the wall box for the reader as well as for the connection cables. The 1-gang / 2-gang card readers allow more space inside single and double device junction boxes.

The procedure must be agreed between all parties involved before the start of the project.

## 5.2 Installation

The card reader enables the hotel room to be opened conveniently. Depending on the design, the card reader can be placed below or above the support ring. The requirements for integration into the JUNG design and matching with the covers must be developed on a project-specific basis.

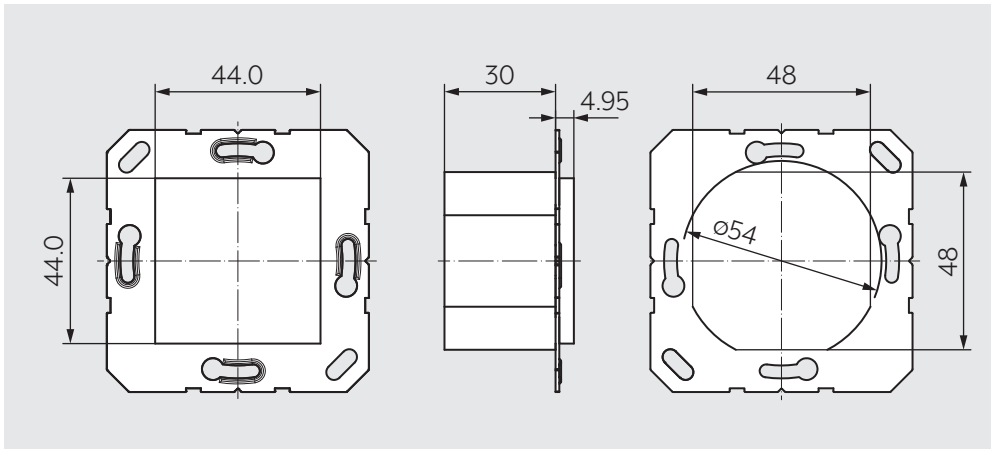

Dimensions of integrable card reader

JUNG can manufacture the holders for the reader for different card reader manufacturers. In this example, the card reader is so large that it only fits in the large box.

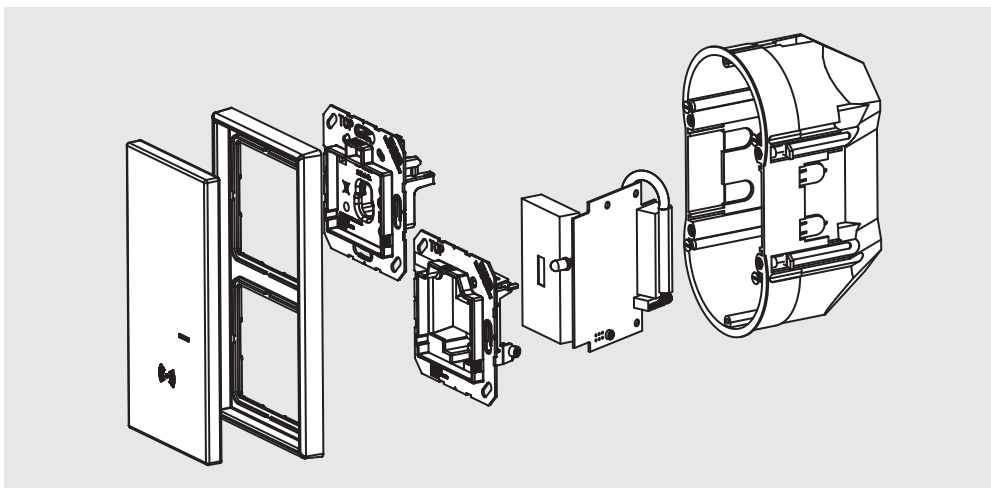

### Example installation of a card reader

Individual planning is necessary for each integration of card readers from different door lock system manufacturers. Architects and planners should contact [international@jung.de](mailto:international@jung.de) for coordination of technical details.

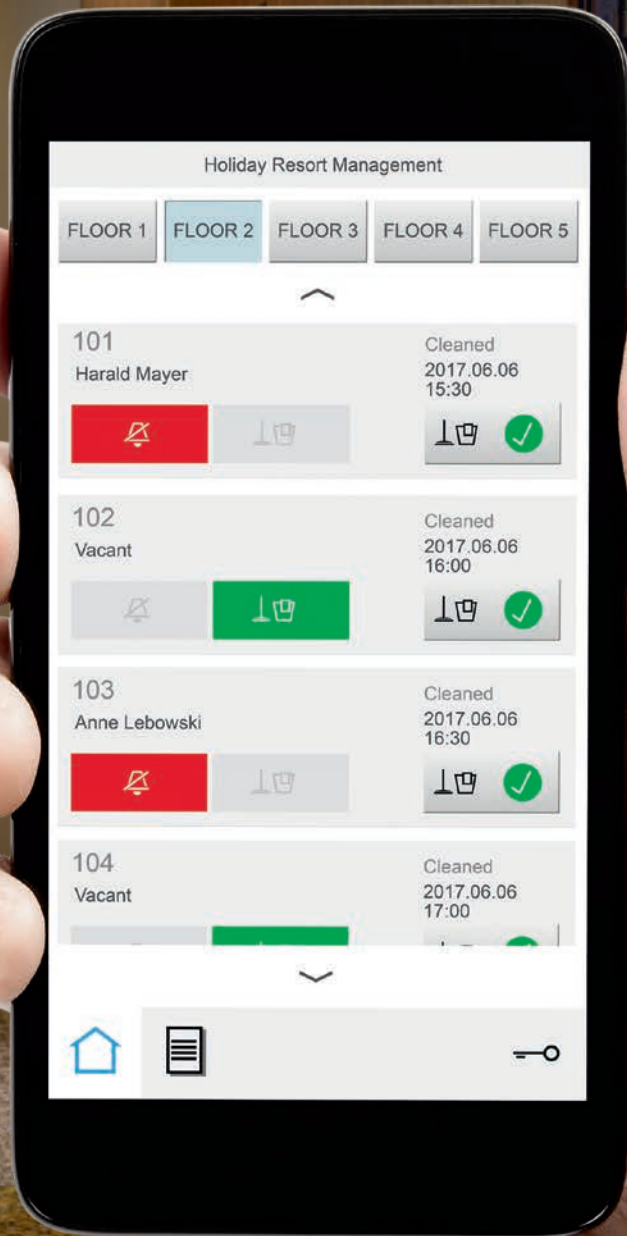

Holiday Resort Management				
FLOOR 1	FLOOR 2	FLOOR 3	FLOOR 4	FLOOR 5
^				
101	Harald Mayer	Cleared	2017.06.06	15:30
102	Vacant	Cleared	2017.06.06	16:00
103	Anne Lebowski	Cleared	2017.06.06	16:30
104	Vacant	Cleared	2017.06.06	17:00
v				

<b>6. HOUSEKEEPING</b>		<b>6.3 OVERVIEW OF ROOM UNITS</b>	<b>111</b>
<b>6.1 OVERVIEW OF CORRIDOR UNITS</b>	<b>103</b>	<b>6.4 ROOM UNITS</b>	<b>112</b>
<b>6.2 CORRIDOR UNITS</b>	<b>104</b>	6.4.1 Inserts	112
6.2.1 Inserts	104	6.4.2 Colour change	113
6.2.2 Lighting	106	6.4.3 Triple-tone door signal	114
6.2.3 Attachments	107	6.4.4 Attachments	115
		6.4.5 Connection	117
		<b>6.5 VISUALISATION VIA KNX</b>	<b>119</b>

## 6. Housekeeping

Thorough housekeeping is the hallmark of a good hotel. With the Corridor and Room Units, JUNG has developed a smart hotel display that provides the guest with the desired peace and quiet and the personnel with the best possible workflows. The hotel display makes communication between guest and personnel clear and convenient by allowing the hotel guest to set the current room status. The statuses "Do not disturb" and "Clean room" are indicated to the hotel personnel via coloured LEDs and pictograms on the Corridor Unit.

### Corridor Units Design

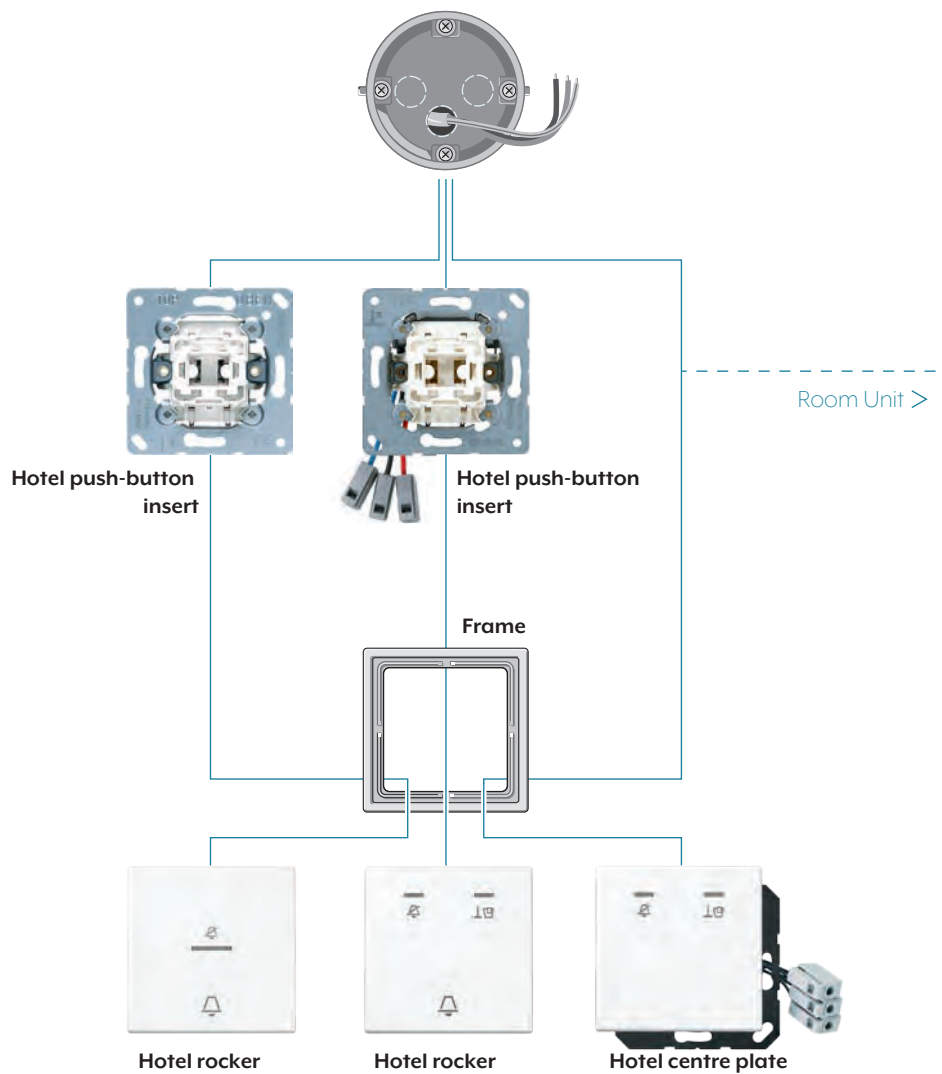

## 6.1 Overview of corridor units

INSERTS	REFERENCE NUMBER
Hotel push-button insert, 24 V, corridor unit	534 KO5 EU D 24
Hotel push-button insert, 230 V, corridor unit	534 KO5 EU D 230
Hotel push-button insert, 24 V, corridor unit	531 KO5 EU M 24
Hotel push-button insert, 230 V, corridor unit	531 KO5 EU M 230
Hotel push-button insert, glass, 24 V, corridor unit	531 KO6 EU M 24

ACCESSORIES	
LED pilot light for glass cover	LED KO6 TX 24
Colour change via separate 2-gang switch	505 KOU5 ..
Triple-tone door signal	.. 567-G3 ..

ATTACHMENTS	RANGE	REFERENCE NUMBER
Hotel rocker, corridor unit (symbol "Do not disturb" and "Bell")	A	A CU KO5 D ..
	LS	.. CU KO5 D ..
Hotel rocker, corridor unit (symbol "Do not disturb", "Make up room" and "Bell")	A	A CU KO5 M ..
	LS	.. CU KO5 M ..
Hotel rocker, glass, with LED unit, 24 V, corridor unit (fade effect with "Do not disturb" and "Make up room" symbol; printed "bell" symbol)	A and AS	A CU KO6 M ..
	LS	LS CU KO6 M ..
Hotel centre plate with LED unit, 24 V, corridor unit (symbol "Do not disturb" and "Make up room")	A	A CU KO5 M 24 ..
	LS	.. CU KO5 M 24 ..
Hotel centre plate with LED unit, 230 V, corridor unit (symbol "Do not disturb" and "Make up room")	A	A CU KO5 M 230 ..
	LS	.. CU KO5 M 230 ..
Hotel centre plate, glass, with LED unit, 24 V, corridor unit (fade effect with "Do not disturb" and "Make up room" symbol)	A and AS	A CU KO6 M 24 ..
	LS	LS CU KO6 M 24 ..

## 6.2 Corridor Units

The Corridor Units show what the guest wants at the moment. The states selected with the Room Units are displayed. In this way, the housekeeping personnel know at a glance whether the guest does not want to be disturbed or whether the room should be explicitly cleaned. In addition, the guest is not suddenly disturbed by the bell function.

### 6.2.1 Inserts

The inserts of the Corridor Units are mounted in a wall box according to DIN 49073.

#### HOTEL PUSH-BUTTON INSERT "DO NOT DISTURB" AND "BELL"

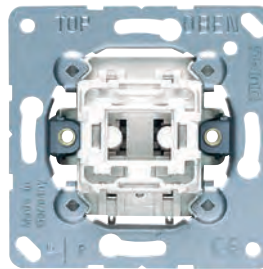

534 KO5 EU D 24 / 230 (HI / LO)

#### CONNECTION AND FUNCTIONS

Design	1-pole NO contact with separate signal contacts for lamps
can be illuminated	red LED lamp, high, low and standard brightness
Spring terminals for rigid conductors up to 2.5 mm <sup>2</sup>	●
Connection terminals according to DIN VDE 0632 (EN 60 669)	●
Screw fastening, without fastening claws	●
Function	<ul style="list-style-type: none"> <li>- Corridor unit signals switching state of the room unit</li> <li>- Push-button is used for actuation of the bell (with optional relay deactivated when "Do not disturb" is selected)</li> </ul>



**HOTEL PUSH-BUTTON INSERT  
"DO NOT DISTURB"**

"Make up room" and "Bell"

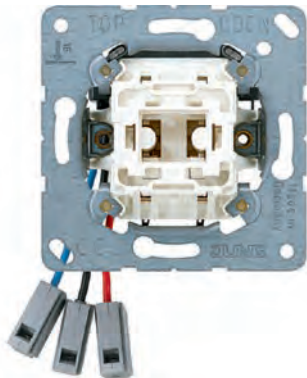

531 KO5 EU M 24 / 230 (HI / LO)

**HOTEL PUSH-BUTTON INSERT  
"DO NOT DISTURB"**

"Make up room" and "Bell"

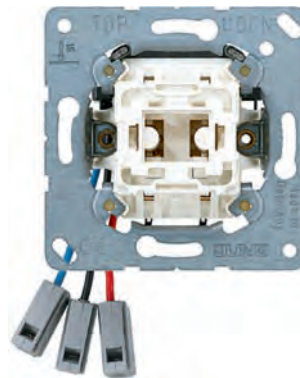

531 KO6 EU M 24

1-pole NO contact	1-pole NO contact
red and green LED lamp, high, low and standard brightness	red and green LED lamp, high, low and standard brightness
●	●
●	●
●	●
<ul style="list-style-type: none"> <li>- Corridor unit signals switching state of the room unit</li> <li>- Push-button is used for actuation of the bell (with optional relay deactivated when "Do not disturb" is selected)</li> </ul>	<ul style="list-style-type: none"> <li>- Corridor unit signals switching state of the room unit</li> <li>- Push-button is used for actuation of the bell (with optional relay deactivated when "Do not disturb" is selected)</li> </ul>

## 6.2.2 Lighting

The LED pilot light enables the lighting of the glass cover .. CU KO5 TX .. of the Corridor Unit. It can be individually labelled with text or symbols. Installation in a wall box according to DIN 49073. The backlighting in white, red, green or orange can be controlled as a colour change via a separate 2-gang switch, for example ref. no.: 505 U or 505 KO5 VEU M 24 (not included in the scope of delivery).

### LED INSERT



LED KO6 TX24

#### CONNECTION AND FUNCTIONS

dimnable	no
Rated voltage	DC 24 V SELV ±10%
Ambient temperature	-5 ... +45 °C
Protection class (for mounted attachment)	⊕
Rated power	< 1.5 W
Connection	Terminal Wago PicoMax 3.5 type 209I-I124
max. usable wire cross-section	0.5 ... 1.5 mm <sup>2</sup>
Function	for backlighting of the covers A CU KO6 TX .. LS CU KO 6 TX ...

### 6.2.3 Attachments

The hotel rocker centre plate (for corridor units with bell function) and the hotel centre plate (for corridor units without bell function) complete the efficient communication system, in addition to the diverse frames of the A, and LS, LS Design and LS Plus ranges. The language-neutral symbols enable problem-free international use. A red illuminated LED indicates that the guest does not want to be disturbed. In the version with two illuminated LEDs, the green LED indicates that housekeeping may enter the room. The guest makes the selection at the corresponding Room Unit, see chapter "6.4 Room Units" on page 112. The Corridor Units can be combined with the card readers in a multiple frame. Visitors or personnel request entry with the bell push-button.

#### Hotel rocker "Do not disturb" and "Bell"

##### A RANGE



MATERIAL	COLOUR	REF. NO.
Duroplastic (scratch-proof), glossy	white	A CU KO5 D WW
	black	A CU KO5 D SW
MATERIAL	COLOUR	REF. NO.
Duroplastic, lacquered	aluminium	A CU KO5 D AL
	champagne	A CU KO5 D CH
	mocha	A CU KO5 D MO
MATERIAL	COLOUR	REF. NO.
Thermoplastic (breakproof) lacquered	matt anthracite	A CU KO5 D ANM

##### LS RANGE



MATERIAL	COLOUR	REF. NO.
Duroplastic (scratch-proof), glossy	ivory	LS CU KO5 D
	white	LS CU KO5 D WW
	light grey	LS CU KO5 D LG
	black	LS CU KO5 D SW
MATERIAL	COLOUR	REF. NO.
Metal versions (* lacquered aluminium)	stainless steel	ES CU KO5 D
	aluminium	AL CU KO5 D
	anthracite *	AL CU KO5 D AN
	dark *	AL CU KO5 DD
	classic brass	ME CU KO5 DC
	antique brass	ME CU KO5 DAT

## Hotel rocker "Do not disturb", "Make up room", "Bell"

## A RANGE



MATERIAL	COLOUR	REF. NO.
Duroplastic (scratch-proof), glossy	white	A CU KO5 M WW
	black	A CU KO5 M SW
MATERIAL	COLOUR	REF. NO.
Duroplastic, lacquered	aluminium	A CU KO5 M AL
	champagne	A CU KO5 M CH
	mocha	A CU KO5 M MO
MATERIAL	COLOUR	REF. NO.
Thermoplastic (breakproof) lacquered	matt anthracite	A CU KO5 M ANM

## LS RANGE



MATERIAL	COLOUR	REF. NO.
Duroplastic (scratch-proof), glossy	ivory	LS CU KO5 M
	white	LS CU KO5 M WW
	light grey	LS CU KO5 M LG
	black	LS CU KO5 M SW
MATERIAL	COLOUR	REF. NO.
Metal versions (* lacquered aluminium)	stainless steel	ES CU KO5 M
	aluminium	AL CU KO5 M
	anthracite *	AL CU KO5 MAN
	dark *	AL CU KO5 MD
	classic brass	ME CU KO5 MC
antique brass	ME CU KO5 MAT	

## Hotel rocker, glass, with LED unit "Do not disturb", "Make up room", "Bell"

## A RANGE



COLOUR	REF. NO.
white	A CU KO6 M WW
black	A CU KO6 M SW

## LS RANGE



COLOUR	REF. NO.
white	LS CU KO6 M WW
black	LS CU KO6 M SW

## Hotel centre plate "Do not disturb", "Make up room" 24 V / 230 V

## A RANGE



MATERIAL	COLOUR	REF. NO.
Thermoplastic (breakproof)	white	A CU KO5 M .. WW
high-gloss	black	A CU KO5 M .. SW

MATERIAL	COLOUR	REF. NO.
Thermoplastic (breakproof)	aluminium	A CU KO5 M .. AL
lacquered	champagne	A CU KO5 M .. CH
	mocha	A CU KO5 M .. MO
	matt anthracite	A CU KO5 M .. ANM

## LS RANGE



MATERIAL	COLOUR	REF. NO.
Thermoplastic (breakproof)	ivory	LS CU KO5 M ..
high-gloss	white	LS CU KO5 M .. WW
	light grey	LS CU KO5 M .. LG
	black	LS CU KO5 M .. SW

MATERIAL	COLOUR	REF. NO.
Metal versions	stainless steel	ES CU KO5 M ..
(* lacquered aluminium)	aluminium	AL CU KO5 M ..
	anthracite *	AL CU KO5 M .. AN
	dark *	AL CU KO5 M .. D
	classic brass	ME CU KO5 M .. C
	antique brass	ME CU KO5 M .. AT

## Hotel centre plate, glass, with LED unit "Do not disturb", "Make up room"

## A RANGE



COLOUR	REF. NO.
white	A CU KO6 M24 WW
black	A CU KO6 M24 SW

## LS RANGE



COLOUR	REF. NO.
white	LS CU KO6 M24 WW
black	LS CU KO6 M24 SW

## Room Units Design

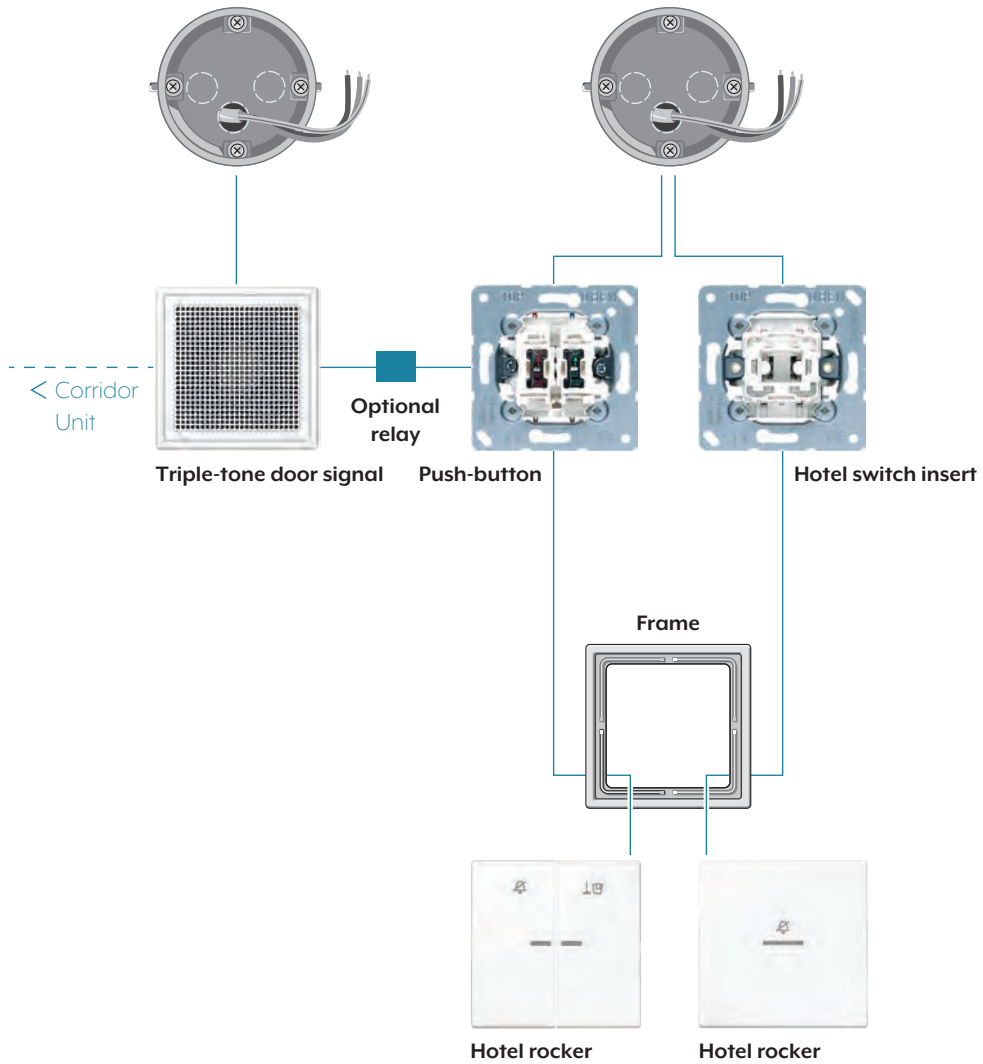

With the optional relay between the 3-tone door signal and the push-button, the bell function is deactivated when "Do not disturb (DND)" is selected. Without relay, the bell function is activated when "Do not disturb (DND)" is selected.

## 6.3 Overview of room units

INSERTS	REFERENCE NUMBER
Hotel switch insert, 24 V, room unit with red LED	506 KO5 EU D 24
Hotel switch insert, 230 V, room unit with red LED	506 KO5 EU D 230
Hotel switch insert, 24 V, room unit with red + green LED	505 KO5 VEU M 24
Hotel switch insert, 230 V, room unit with red + green LED	505 KO5 VEU M 230

ACCESSORIES	RANGE	REFERENCE NUMBER
2-gang switch with two replaceable glow lamps		505 KOU5 ..
Triple-tone door signal	AS, A	A 567-G3 ..
	CD	CD 567-G3 ..
	LS	LS 567-G3 ..

ATTACHMENTS	RANGE	REFERENCE NUMBER
Hotel rocker, room unit (with indicator light + symbol "DND")	A	A RU KO5 D ..
	LS	.. RU KO5 D ..
Hotel rocker (with indicator light + symbols "DND", "MUR")	A	A RU KO5 M ..
	LS	.. RU KO5 M ..

## 6.4 Room Units

Using the Room Units, the guest selects the state that should be indicated on the Corridor Units. He can select whether the room should be cleaned or whether he does not want to be disturbed. In addition, the bell function of the Corridor Unit can be disabled for some combinations on the Room Unit. This ensures an undisturbed stay for the guest and smooth workflows for the personnel.

### 6.4.1 Inserts

The inserts of the Room Units are mounted in a wall box according to DIN 49073.

HOTEL SWITCH INSERT

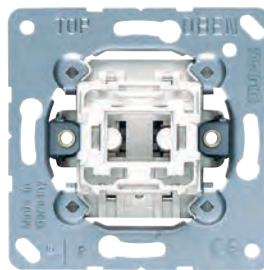

506 KO5 EU D 24 / 230 (HI / LO)

HOTEL SWITCH INSERT

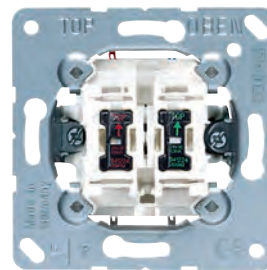

505 KO5 VEU M 24 / 230 (HI / LO)

#### CONNECTION AND FUNCTIONS

	Universal 1-pole, 2-way	2-gang switch
Design	Universal 1-pole, 2-way	2-gang switch
can be illuminated	red LED lamp, high, low and standard brightness	red and green LED lamp high, low and standard brightness
Spring terminals for rigid conductors up to 2.5 mm <sup>2</sup>	●	●
Connection terminals according to DIN VDE 0632 (EN 60 669)	●	●
Screw fastening, without fastening claws	●	●
Function	<ul style="list-style-type: none"> <li>- The room unit is used exclusively for controlling the LEDs of the corridor unit</li> </ul>	<ul style="list-style-type: none"> <li>- The room unit is used exclusively for controlling the LEDs of the corridor unit</li> <li>- Push-buttons are mutually mechanically interlocked</li> </ul>



### 6.4.2 Colour change

The Room Unit can be discreetly illuminated with an additional 2-gang switch. This way, the guest always knows which state he has just selected. The glow lamps can be replaced from the outside and it is also possible to use coloured LEDs in red and green.

#### 2-GANG SWITCH WITH INDICATOR LIGHT 1-POLE, 1-WAY WITH 2 GLOW LAMPS 505 KOU 5

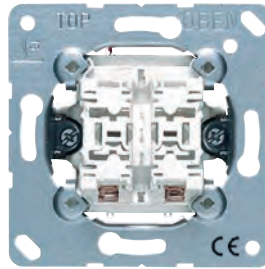

#### CONNECTION AND FUNCTIONS

Rated voltage	DC 24 V SELV
Rated power	< 1.5 W
Ambient temperature	-5 ... +45 °C

### 6.4.3 Triple-tone door signal

The triple-tone door signal can be integrated into the Room Unit and thus blends in with the design specifications of the hotel room. The different versions are all supplied complete with support ring and screw fastening. The power supply is 8 ... 12 V AC or 8 ... 12 V DC and is ensured by an external power supply (e.g. NZ 2405 VDC or NT 2415 REG VDC). Dismounting protection (ref. no.: M-DMS) is available as an accessory.

#### Triple-tone door signal

##### A RANGE



MATERIAL	COLOUR	REF. NO.
Thermoplastic (breakproof) high-gloss	white	A 567-G3 WW
	black	A 567-G3 SW
MATERIAL	COLOUR	REF. NO.
Thermoplastic (breakproof) lacquered	aluminium	A 567-G3 AL
	champagne	A 567-G3 CH
	mocha	A 567-G3 MO
	matt anthracite	A 567-G3 ANM

##### CD RANGE



MATERIAL	COLOUR	REF. NO.
Thermoplastic (breakproof) high-gloss	ivory	CD 567-G3
	white	CD 567-G3 WW

##### LS RANGE



MATERIAL	COLOUR	REF. NO.
Thermoplastic (breakproof) high-gloss	ivory	LS 2567-G3
	white	LS 2567-G3WW
MATERIAL	COLOUR	REF. NO.
Metal versions (* lacquered aluminium)	aluminium	AL 2567-G3
	stainless steel *	ES 2567-G3
	anthracite *	AL 2567-G3 AN

## 6.4.4 Attachments

### Hotel rocker "Do not disturb"

#### A RANGE



MATERIAL	COLOUR	REF. NO.
Duroplastic (scratch-proof), glossy	white	A RU KO5 D WW
	black	A RU KO5 D SW

MATERIAL	COLOUR	REF. NO.
Duroplastic, lacquered	aluminium	A RU KO5 D AL
	champagne	A RU KO5 D CH
	mocha	A RU KO5 D MO

MATERIAL	COLOUR	REF. NO.
Thermoplastic (breakproof) lacquered	matt anthracite	A RU KO5 D ANM

#### LS RANGE



MATERIAL	COLOUR	REF. NO.
Duroplastic (scratch-proof), glossy	ivory	LS RU KO5 D
	white	LS RU KO5 D WW
	light grey	LS RU KO5 D LG
	black	LS RU KO5 D SW

MATERIAL	COLOUR	REF. NO.
Metal versions (* lacquered aluminium)	stainless steel	ES RU KO5 D
	aluminium	AL RU KO5 D
	anthracite *	AL RU KO5 D AN
	dark *	AL RU KO5 D D
	classic brass	ME RU KO5 D C
	antique brass	ME RU KO5 D AT

## Hotel rocker "Do not disturb" and "Make up room"

## A RANGE



MATERIAL	COLOUR	REF. NO.
Duroplastic (scratch-proof), glossy	white	A RU KO5 M WW
	black	A RU KO5 M SW
MATERIAL	COLOUR	REF. NO.
Duroplastic, lacquered	aluminium	A RU KO5 M AL
	champagne	A RU KO5 M CH
	mocha	A RU KO5 M MO
MATERIAL	COLOUR	REF. NO.
Thermoplastic (breakproof) lacquered	matt anthracite	A RU KO5 M ANM

## LS RANGE



MATERIAL	COLOUR	REF. NO.
Duroplastic (scratch-proof), glossy	ivory	LS RU KO5 M
	white	LS RU KO5 M WW
	light grey	LS RU KO5 M LG
	black	LS RU KO5 M SW
MATERIAL	COLOUR	REF. NO.
Metal versions (* lacquered aluminium)	stainless steel	ES RU KO5 M
	aluminium	AL RU KO5 M
	anthracite *	AL RU KO5 M AN
	dark *	AL RU KO5 M D
	classic brass	ME RU KO5 M C
antique brass	ME RU KO5 M AT	

### 6.4.5 Connection

"Do not disturb" and "Make up room", 24 V DC

Hotel switch insert room unit [2] with hotel switch insert corridor unit with bell [3] and optional relay [1].

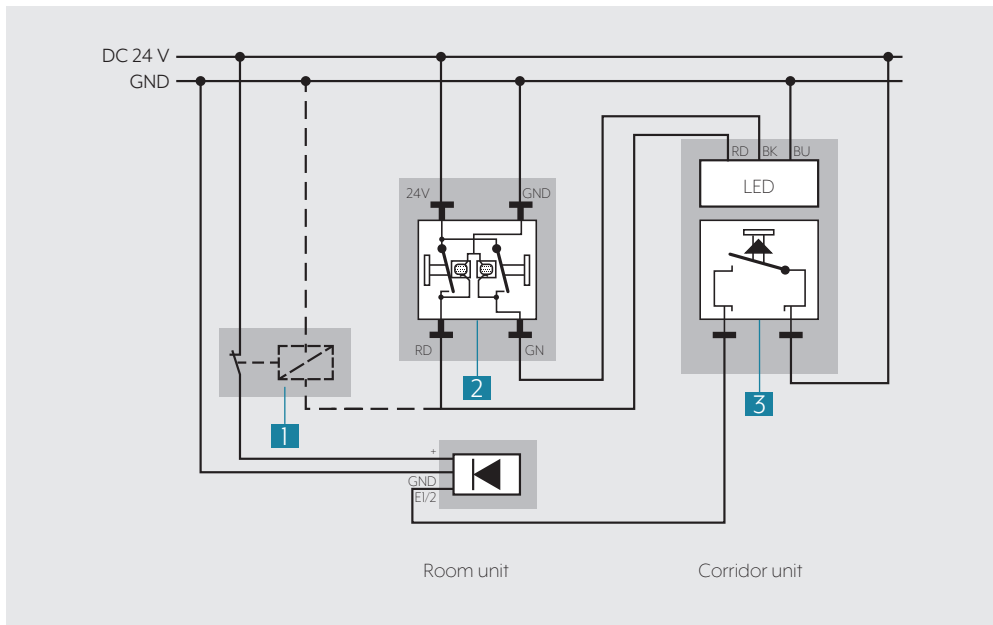

"Do not disturb" and "Make up room", 24 V DC

Hotel switch insert room unit [1] and hotel centre plate corridor unit without bell [2].

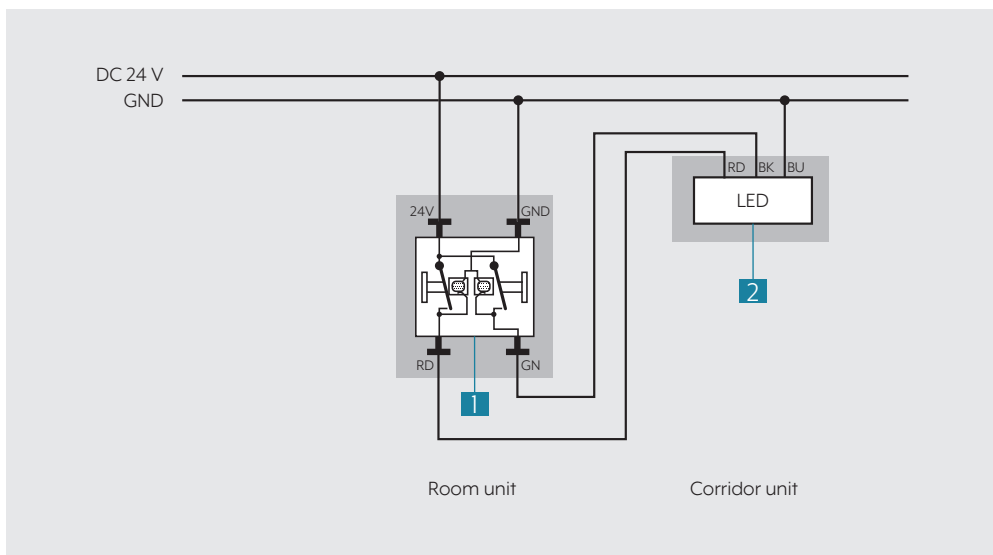

"Do not disturb" and "Make up room", 230 V~ AC

Hotel switch insert room unit [2] with hotel switch insert corridor unit with bell [3] and optional relay [1].

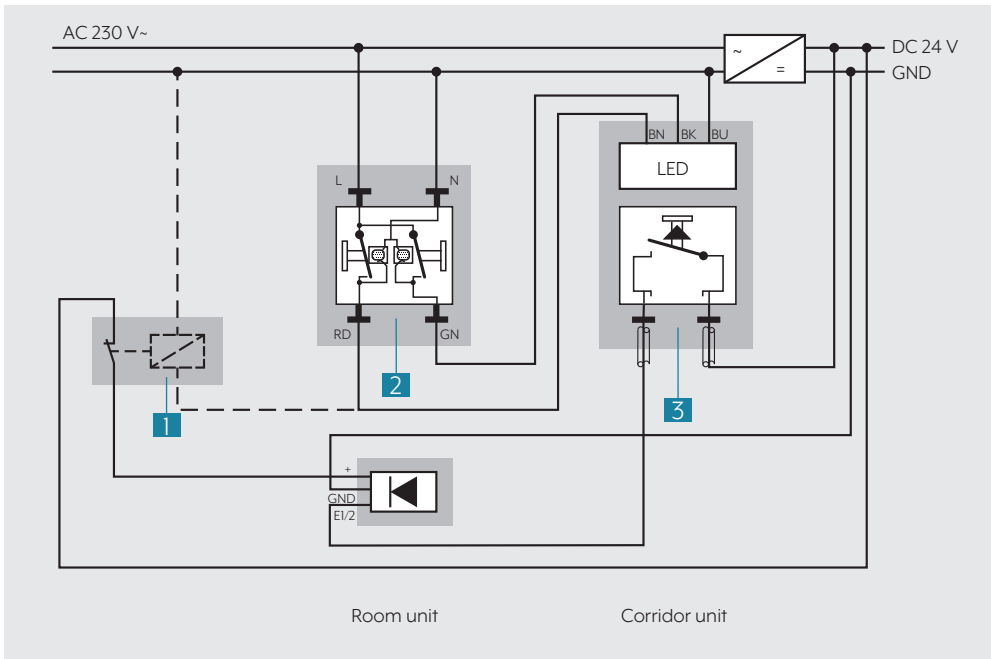

"Do not disturb" and "Make up room", 230 V~ AC

Hotel switch insert room unit [1] and hotel switch insert corridor unit without bell [2].

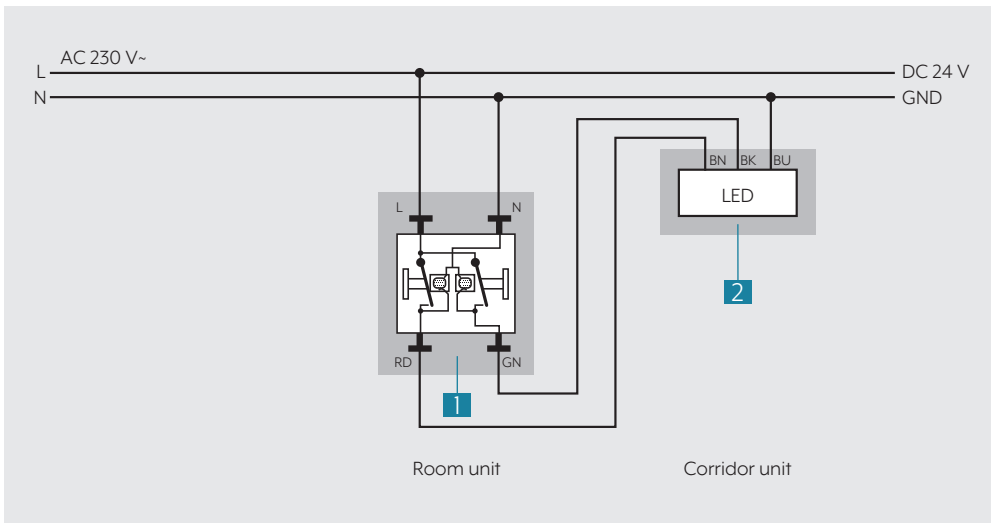

## 6.5 Visualisation via KNX

The connection of the Corridor and Room Units to the KNX system visualises the activities to be performed for housekeeping. The personnel can see on a mobile device which guests wish to remain undisturbed and which rooms should be cleaned. When the work has been completed, the personnel indicate via the mobile device that the room is finished.

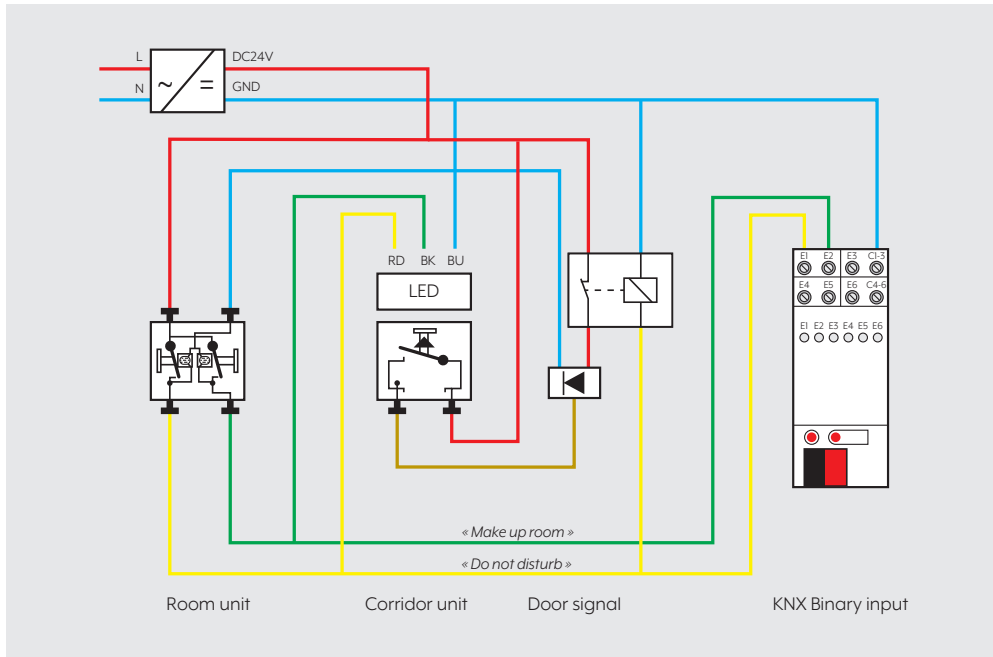

Beyond the direct communication between guest and personnel at the hotel room door, the information is also visible at the reception desk.



104





<b>7. KEY CARD HOLDER</b>		<b>7.3 ELECTRONIC RFID KEY CARD HOLDER</b>	<b>10</b>
<b>7.1 EQUIPMENT OVERVIEW</b>	<b>4</b>	7.3.1 Inserts	11
<b>7.2 MECHANICAL KEY CARD HOLDER</b>	<b>5</b>	7.3.2 Attachments	12
7.2.1 Inserts	5	7.3.3 Accessories	14
7.2.2 Lighting	7	7.3.4 Key cards	14
7.2.3 Attachments	8	7.3.5 Connection	15
7.2.4 Connection	9	7.3.6 Key Card Configurator	16
		7.3.7 RFID key card holder with ASSA ABLOY	16

## 7. Key card holder

Key card holders are practical, economical, convenient and increase electrical operational reliability. The circuits for lighting, heating and ventilation are switched on when a card is inserted into key card holder. If the hotel guest removes the card when leaving the room, the circuits are disconnected and thus the connected consumers are automatically switched off. The requirement determines the functionality for a key card holder. Depending on the technical requirement, there is a mechanical and an electronic version. The electronic RFID key card holder can also be individually programmed via the "Key Card Configurator".

Both before the installation as well as in the installed state. Both solutions increase comfort for the hotel guest, optimise energy consumption and thereby reduce operating costs.

The mechanical key card holder works with all cards. The electronic version only works with cards according to ISO standard ISO/IEC 14443 and ISO/IEC 15693.

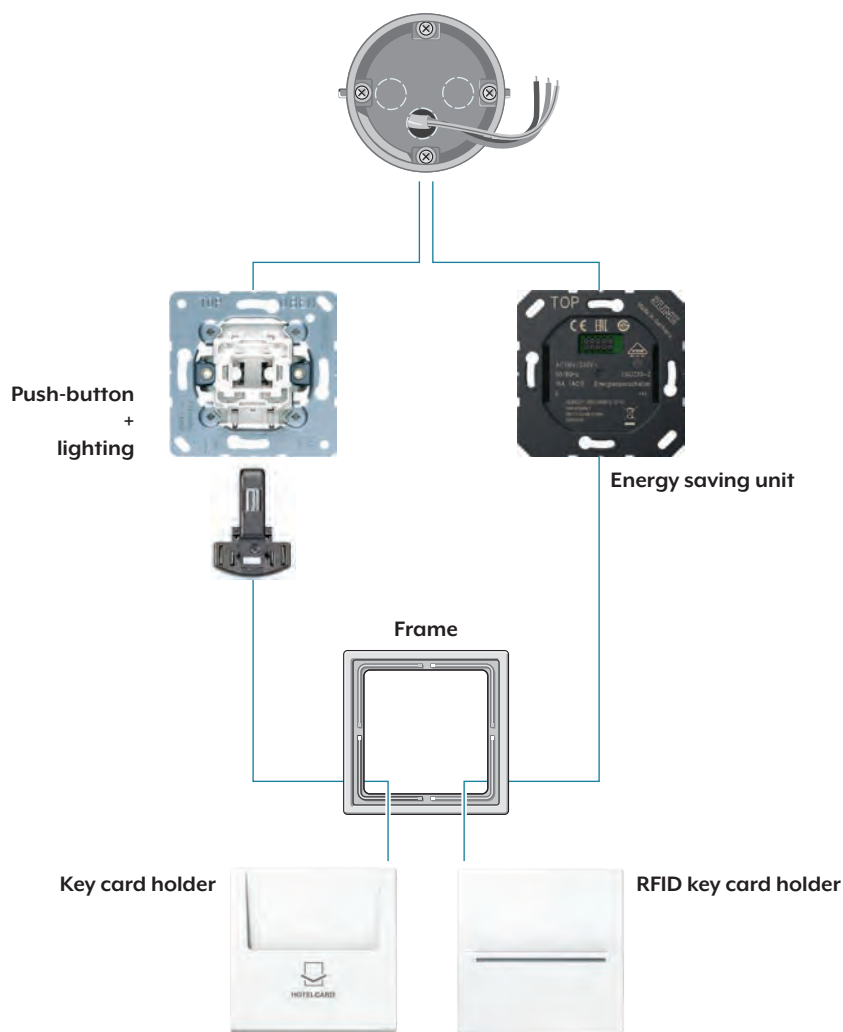

## 7.1 Equipment Overview

INSERTS	REFERENCE NUMBER
Push-button 10 AX 250 V ~, 1-pole NO contact	531 U
Push-button 10 AX 250 V ~, 2-pole NO contact	532 U
Push-button 10 AX 250 V ~, 1-pole changeover contact with N terminal	533 U
Push-button 10 AX 250 V ~, 1-pole NO contact with separate signal contacts for lamps	534 U
Energy saving unit	ESU 230-2

ACCESSORIES	REFERENCE NUMBER
Glow lamp 230 V ~, 1.1 mA, 0.25 W	90
Glow lamp 230 V ~, 0.5 mA, 0.11 W	95
Incandescent lamp 12 V ~, 40 mA, 0.48 W	96-12
Incandescent lamp 24 V ~, 25 mA, 0.60 W	96-24
Incandescent lamp 36 V ~, 20 mA, 0.72 W	96-36
Incandescent lamp 48 V ~, 25 mA, 1.20 W	96-48
LED lamp, various colours 12-48 V ~, 4 mA, 0.19 W	961248 LED red or green
LED lamp, various colours 230 V ~, 1.1 mA, 0.25 W	90-LED red or green

ATTACHMENTS	RANGE	REFERENCE NUMBER
Key card holder	A	A 590 CARD ..
	CD	CD 590 CARD ..
	LS	LS 590 CARD ..
		.. 2990 CARD ..
RFID key card holder	A	A CARD RFID ..
	LS	.. CARD RFID ..

ACCESSORIES	RANGE	REFERENCE NUMBER
RFID configuration card	A	CONFIG RFID

## 7.2 Mechanical key card holder

The mechanical key card holder meets the conventional requirements: If a card is inserted into the key card holder, the circuits are open. The card is kept safely in the hotel room during the stay and is only removed when the guest leaves. All consumers in the room are immediately switched off without delay. This enables economical energy use and also increases electrical safety by disconnecting the voltage.

The mechanical key card holder consists of two components: an insert and an attachment.

### 7.2.1 Inserts

The inserts are mounted in a wall box according to DIN 49073.

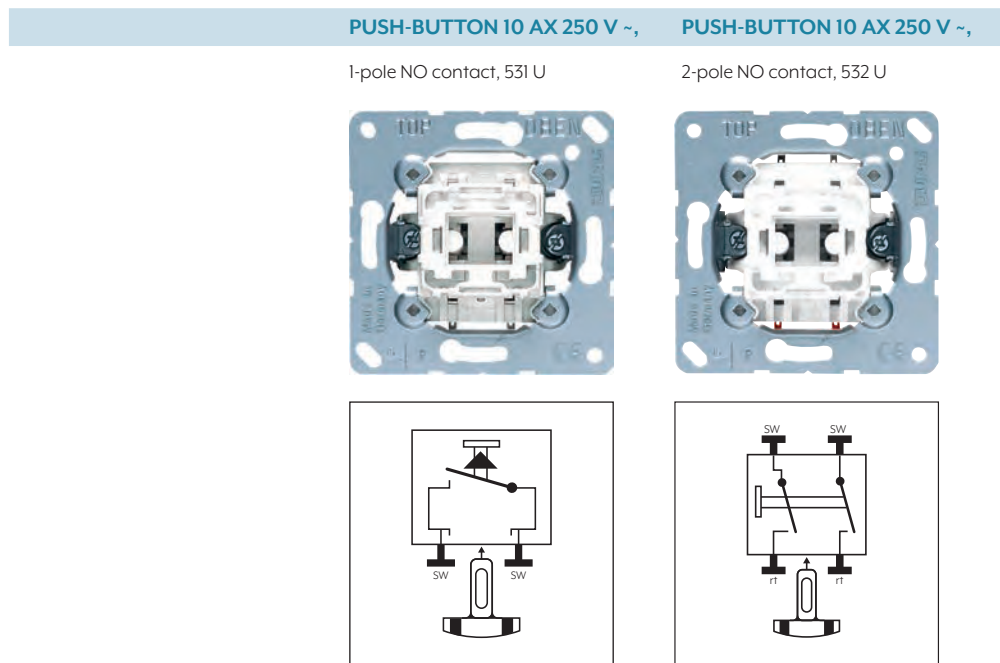

CONNECTION AND FUNCTIONS		
can be illuminated	●	●
Spring terminals for rigid conductors up to 2.5 mm <sup>2</sup>	●	●
Connection terminals according to DIN VDE 0632 (EN 60 669)	●	●
without fastening claws if required	●	●
Function	<ul style="list-style-type: none"> <li>- One-pole contactor</li> <li>- can be illuminated in switched-off mode</li> <li>- one action is enabled (for example master on/off)</li> </ul>	<ul style="list-style-type: none"> <li>- Two-pole contactor</li> <li>- can be illuminated</li> <li>- two actions can be switched simultaneously (for example light and ventilation system)</li> </ul>

**PUSH-BUTTON 10 AX 250 V ~,**

**PUSH-BUTTON 10 AX 250 V ~,**

1-pole changeover contact with N terminal, 533 U

1-pole NO contact with separate signal contacts for lamps, 534 U

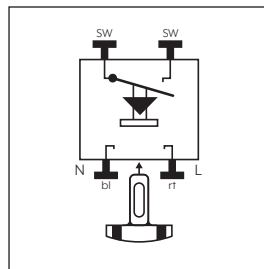
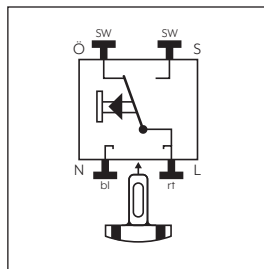
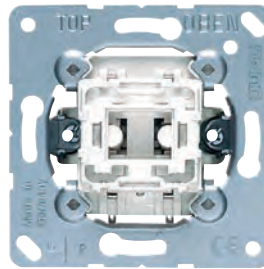
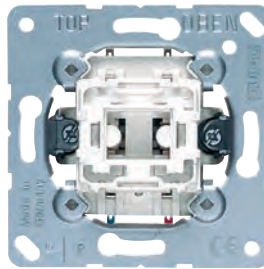

**CONNECTION AND FUNCTIONS**

can be illuminated	●	●
Spring terminals for rigid conductors up to 2.5 mm <sup>2</sup>	●	●
Connection terminals according to DIN VDE 0632 (EN 60 669)	●	●
without fastening claws if required	●	●
Function	<ul style="list-style-type: none"> <li>- Single-pole 2-way switch (with connector for short-circuiting N conductor)</li> <li>- can be illuminated</li> <li>- one action is enabled (for example master on/off)</li> </ul>	<ul style="list-style-type: none"> <li>- Single-pole contactor (with separate signal contacts for lamps)</li> <li>- can be illuminated</li> <li>- one action is enabled (for example master on/off)</li> </ul>

## 7.2.2 Lighting

A choice of different lamps is available depending on the voltage and the desired brightness on site. The LED lamps are also available in the colours red and green.

<b>LIGHTING</b>	<b>REFERENCE NUMBER</b>
Glow lamp 230 V ~, 1.1 mA, 0.25 W	90
Glow lamp 230 V ~, 0.5 mA, 0.11 W	95
Incandescent lamp 12 V ~, 40 mA, 0.48 W	96-12
Incandescent lamp 24 V ~, 25 mA, 0.60 W	96-24
Incandescent lamp 36 V ~, 20 mA, 0.72 W	96-36
Incandescent lamp 48 V ~, 25 mA, 1.20 W	96-48
LED lamp, red, 12-48 V ~, 4 mA, 0.19 W	961248 LED RT
LED lamp, green, 12-48 V ~, 4 mA, 0.19 W	961248 LED GN
LED lamp, red, 12-230 V ~, 1.1 mA, 0.25 W	90-LED RT
LED lamp, green, 12-230 V ~, 1.1 mA, 0.25 W	90-LED GN

### 7.2.3 Attachments

In addition to the diverse frames of the A, CD, LS,

LS Design and LS Plus ranges, the key card holder cover completes the efficient storage system. The key card holder is completed with a push-button from the JUNG range. The push-button ref. no. 533 U with NC / NO contact and an additional N-terminal is recommended. Depending on the connection, the device operates as a normally closed (NC) contact or normally open (NO) contact. The separate N terminal allows a glow, incandescent or LED lamp to be operated at the same voltage. Then the key card holder is also always visible in the dark.

If the pilot lamp should not be at the same voltage, the normally open push-button ref. no. 534 U with a separate signalling contact can also be used.

Installation information: No plaster compensation is possible. The insert must be mounted flush with the wall.

The support ring must not be papered over. It is possible to obtain the key card holder with the inscription "Key Card", without inscription or with individual inscription. The latter can be printed on the switch or engraved by laser.

#### Key card holder (without push-button insert)

##### A RANGE



MATERIAL	COLOUR	REF. NO.
Thermoplastic (breakproof) high-gloss	ivory	A 590 CARD
	white	A 590 CARD WW
	black	A 590 CARD SW
MATERIAL	COLOUR	REF. NO.
Thermoplastic (breakproof) lacquered	aluminium	A 590 CARD AL
	champagne	A 590 CARD CH
	mocha	A 590 CARD MO
	matt anthracite	A 590 CARD ANM

##### CD RANGE



MATERIAL	COLOUR	REF. NO.
Thermoplastic (breakproof) high-gloss	white	CD 590 CARD WW
MATERIAL	COLOUR	REF. NO.
Lacquered metal versions	gold bronze	CD 590 CARD GB-L
	platinum	CD 590 CARD PT-L

##### LS RANGE



MATERIAL	COLOUR	REF. NO.
Thermoplastic (breakproof) high-gloss	ivory	LS 590 CARD
	white	LS 590 CARD WW
	light grey	LS 590 CARD LG
	black	LS 590 CARD SW
MATERIAL	COLOUR	REF. NO.
Lacquered metal versions	aluminium	AL 2990 CARD
	stainless steel	ES 2990 CARD
	anthracite	AL 2990 CARD AN
	dark	AL 2990 CARD D
	classic brass	ME 2990 CARD C
	antique brass	ME 2990 CARD AT

### 7.2.4 Connection

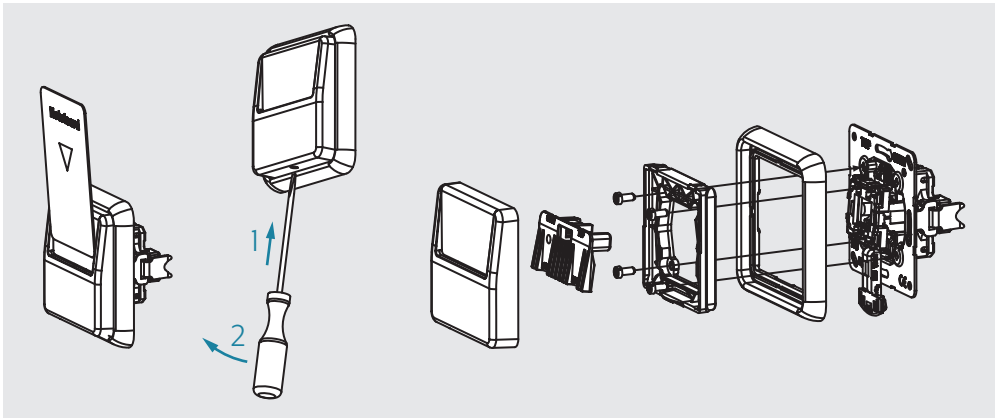

1. Connect the required push-button insert according to the wiring diagram.

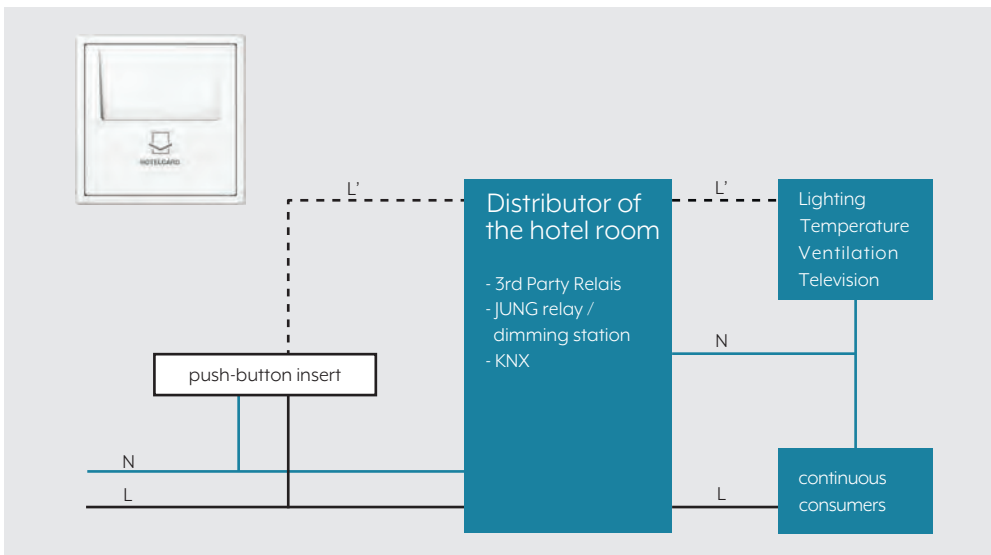

2. Mount the insert in the wall box. The connection terminals must be facing down. The inscription TOP faces upwards. Mount the attachment onto the insert.



### 7.3 Electronic RFID key card holder

The JUNG RFID key card holder works with RFID cards from various manufacturers. The electronic key card holder combines the compliance with basic requirements with more advanced technical convenience. Various optical signals can be given via individually adjustable indicator light colours. It is possible to choose between the colours blue, green and red.



The feedback LEDs of the key card holder light in one colour to indicate that it is operational. The circuits are enabled by inserting the key card and the indicator light shows this by changing to the predefined colour. The coloured indicator goes out after a preset time. If the card is removed, a previously defined circuit is disconnected and the indicator flashes in the activity colour for a selected period of time. For example, the lamp in the door area can continue to glow for easy orientation. All circuits of the room are not switched off until the indicator goes out.

After another individual time window, the indicator lamp lights again as a pilot light and the circuits of the room are switched off.

The intelligent key card holder in the JUNG design works with the Visionline software from Assa Abloy VingCard. This software is distributed exclusively by Assa Abloy Hospitality, see chapter “7.3.7 RFID key card holder with ASSA ABLOY” on page 135. In addition to the conventional requirements and the feedback LEDs of the other key card holders, the device provides the option of saving different profiles: if the guest card starts a scene with atmospheric lighting and suitable air conditioning, the personnel card only switches on the required basic lighting for cleaning.

### 7.3.1 Inserts

The energy saving unit ESU 230-2 is mounted in a wall box according to DIN 49073.

#### ENERGY SAVING UNIT ESU 230-2



#### CONNECTION AND FUNCTIONS

Rated voltage	AC 110 ... 230 V ~	
Mains frequency	50/60 Hz	
Switching current AC1 (cos > 0.8)	16 A	
Switch type	2 NO contacts, one NO contact with configurable shut-off delay	
Connection type	Screw terminals	
Connected load 230 V output 1 (O1)	Ohmic	3000 W
	Motors	1160 VA
	HV halogen lamps	1000 W
	Electronic transformers with LV halogen lamps	1000 W
	Output 2 (O2)	Shut-off delay 0 ... 240 s (60 s)
Power reduction	Ohmic	3000 W
	Capacitive	16 A / 140 µF
	Motors	1380 VA
	HV halogen lamps	2500 W
	Electronic transformers with LV halogen lamps	1500 W
	Inductive transformers with LV halogen lamps	1200 VA
	HV LED lamps	typical 400 W
Function	per 5 °C exceeding 25 °C -10%	
	for installation in wood or dry wall -15%	
	for installation in multiple combinations -20%	
Programmability	- Operation with RFID cards according to RFID standard ISO/IEC 14443 and ISO/IEC 15693	
	- Status display via RGB indicator lights	
Function	- before the installation using the Key Card Configurator available online	
	- already installed using the RFID configuration card	

### 7.3.2 Attachments

The RFID key card holder is used to store the key card and to ensure a high level of safety, as all electrical consumers that are switched on are switched off with an adjustable shut-off delay when the key card is removed.

The new RFID key card holder (with update V 1.1) has been developed for two applications:

1. As a JUNG product, it is available for universal application.
2. As OEM product, it is developed for different key card manufacturers.

The RFID key card holder recognises various card types. Within the JUNG product range, the key card holder recognises cards according to the ISO/IEC 14443 and ISO/IEC 15693 standards. The product cannot differentiate between guest and personnel cards.

For example, the key card holder is manufactured as an OEM product for Assa Abloy Hospitality. Two different card types are defined for use here: on the one hand, the MIFARE Classic® card as a commissioning and personnel card. On the other hand, the MIFARE Ultralight® C card as guest card. Both cards comply with the ISO/IEC 14443 and ISO/IEC 15693 standards. The device can differentiate between card types due to programming by the OEM customer. The Ultralight® C card type also allows "payment by card". The software update of the key card holder (version 1.1) also enables the higher current consumption caused by the larger data storage of the card.

At <https://www.jung.de/en/6693/service/hotelcard-configurator/> you can adjust the indicator light colour and brightness as well as the shut-off delay of the second NO contact to your personal preferences. In addition, individual laser inscription [L] is possible.

#### Overview of the functions:

- Operation with card type Classic® and Ultralight® C
- Status display via RGB indicator lights
- Indicator light colour and brightness can be customised at <https://www.jung.de/en/6693/service/hotelcard-configurator/>
- Dimming of the indicator light 30 seconds after insertion of the cards
- Signalling of the shut-off delay after card removal via RGB indicator light

## RFID key card holder with update V 1.1

## A RANGE



MATERIAL	COLOUR	REF. NO.
Thermoplastic (breakproof) high-gloss	white <b>L</b>	A CARD RFID WW
	black <b>L</b>	A CARD RFID SW

MATERIAL	COLOUR	REF. NO.
Thermoplastic (breakproof) lacquered	aluminium <b>L</b>	A CARD RFID AL
	champagne	A CARD RFID CH
	mocha	A CARD RFID MO
	matt anthracite <b>L</b>	A CARD RFID ANM

**L** Laser engraving possible

## LS RANGE



MATERIAL	COLOUR	REF. NO.
Thermoplastic (breakproof) high-gloss	ivory <b>L</b>	LS CARD RFID
	white <b>L</b>	LS CARD RFID WW
	light grey <b>L</b>	LS CARD RFID LG
	black <b>L</b>	LS CARD RFID SW

**L** Laser engraving possible

MATERIAL	COLOUR	REF. NO.
Lacquered metal versions	aluminium	AL CARD RFID
	stainless steel	ES CARD RFID
	anthracite	AL CARD RFID AN
	dark	AL CARD RFID D
	classic brass	ME CARD RFID C
	antique brass	ME CARD RFID AT

### 7.3.3 Accessories

#### RFID CONFIGURATION CARD



##### DESCRIPTION

With the RFID configuration card, you can configure the indicator light colour and brightness as well as the shut-off delay of the second relay for key card holders that are already installed.

Further information can be found at <https://www.jung.de/en/6693/service/hotelcard-configurator/>.

##### OVERVIEW OF THE FUNCTIONS

- Suitable for operation with RFID key card holder
- Individually adjustable indicator light colour and brightness
- Adjustable shut-off delay of the second relay

### 7.3.4 Key cards

The cards listed below have been tested with the JUNG RFID key card holder.

As the perfect function is also always related to the quality of the card batch, the customer can have a card of the used card type tested by JUNG free of charge. The contact for this is the Hotline.

---

MIFARE Ultralight EV1 (MFOUL1101DUx)

---

MIFARE Classic EV1 (MFIS703xX/V1)

---

MIFARE Ultralight (MFOICU1)

---

MIFARE Ultralight (MFOICU1)

---

MIFARE PLUS S (MFISPLUSx0)

---

MIFARE DESFire EV1 (MF3ICD21)

---

MIFARE Classic (MFIS50)

---

MIFARE Classic (EV1)(MFIS70)

---

MIFARE DESFire EV1 (MF3ICD81)

---

NTAG216

---

Unknown Mifare classic IC

---

MIFARE Ultralight EV1 (MFOUL1101DUx)

---

MIFARE Ultralight EV1 (MFOUL1101DUx)

---

MIFARE Ultralight (unknown type)

---

(MFOICU1)

---

### 7.3.5 Connection

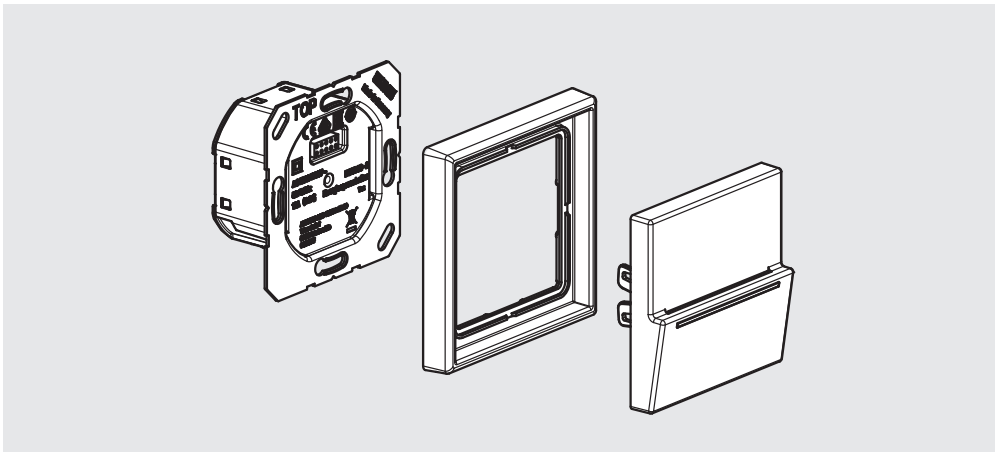

1. Connect the key card holder according to the wiring diagram.

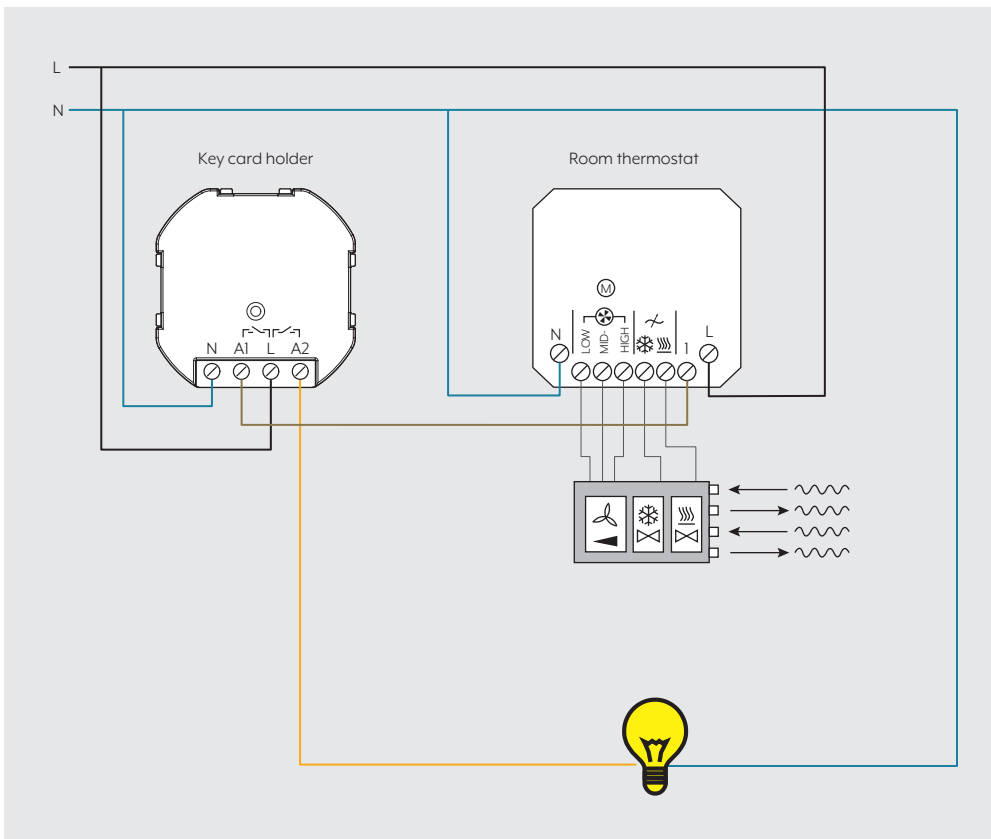

2. Mount the insert in the wall box. The connection terminals must be facing down. The inscription TOP faces upwards.
3. Mount the attachment onto the insert.

### 7.3.6 Key Card Configurator

Make the basic settings using the key card configurator. Here you adjust the colour and brightness of the LEDs on the RFID key card holder according to your individual requirements and preferences. The time of the delayed shut-off of the lighting after removal of the card can also be set here. All hotel rooms are quickly set with one configuration – time and energy savings for the hotel operator speak for the system.

1. Open <https://www.jung.de/en/6693/service/hotelcard-configurator/> in your web browser.
2. Log in using the login details of your MyJUNG account.
3. If you do not yet have a MyJUNG account, click on the "To register" button and register for a MyJUNG account.
4. Enter the required data (project name, project manager, property location, planned installation date, property country) and then select the desired colour and brightness of the LED lamp without the hotel card inserted.
5. Specify the duration of the lighting as feedback after insertion of the card and the desired brightness with inserted key card in the RFID key card holder. Also enter the duration of the power supply after removal of the key card.

### 7.3.7 RFID key card holder with ASSA ABLOY

In addition to the RFID key card holder, Assa Abloy Hospitality provides an intelligent key card holder in the JUNG design. The VingCard is distributed by Assa Abloy and blends in with the design of the JUNG Hospitality range. The device has the additional option to store different profiles. While the personnel card only switches on the basic lighting required for cleaning, the guest card starts a scene with atmospheric lighting and suitable air conditioning. Individual guest requirements for lighting and air conditioning can also be configured before his visit.



# ASSA ABLOY

ASSA ABLOY Sicherheitstechnik GmbH  
 Bildstockstraße 20  
 D-72458 Albstadt  
 GERMANY  
 Tel. +49 (0) 7431 123 -0  
 Fax +49 (0) 7431 123-2 40

albstadt@assaabloy.com  
 www.assaabloy.com





<b>8.</b>	<b>ORIENTATION AND INFORMATION LIGHTING</b>	
<b>8.1</b>	<b>SCHUKO® AND GLASS COVER OVERVIEW</b>	<b>139</b>
<b>8.2</b>	<b>OVERVIEW OF LED PILOT LIGHTS</b>	<b>141</b>
<b>8.3</b>	<b>SCHUKO® SOCKET WITH LED FLOOR PILOT LIGHT</b>	<b>142</b>
8.3.1	Inserts	142
8.3.2	Connection	143
<b>8.4</b>	<b>LED PILOT LIGHT WITH INTEGRATED BRIGHTNESS SENSOR</b>	<b>144</b>
8.4.1	Inserts	144
8.4.2	Connection	146
<b>8.5</b>	<b>LED INFO SIGN</b>	<b>147</b>
8.5.1	Inserts	147
8.5.2	Attachments	148
8.5.3	Connection	149
<b>8.6</b>	<b>LED PILOT LIGHT WITH TRAFFIC LIGHT FUNCTION</b>	<b>151</b>
8.6.1	Inserts	151
8.6.2	Attachments	151
8.6.3	Connection	152
<b>8.7</b>	<b>LED READING LIGHT</b>	<b>153</b>
8.7.1	Inserts	153
8.7.2	Attachments	153
8.7.3	Connection	153
<b>8.8</b>	<b>LED PILOT LIGHT RGB, BLUE, WHITE</b>	<b>155</b>
8.8.1	Inserts	155
8.8.2	Attachments	155
8.8.3	Connection	155
<b>8.9</b>	<b>PLUG &amp; LIGHT AS PILOT LIGHTS</b>	<b>157</b>
<b>8.10</b>	<b>LED GLASS COVER</b>	<b>158</b>
8.10.1	Insert	159
8.10.2	Attachments	160
8.10.3	Connection	161

## 8. Orientation and information lighting

JUNG provides various options for safe orientation. In addition to the discreet variant of integrating a coherent pilot light into covers and switches (see, for example, chapter “5. Card reader” on page 98 and chapter “7. Key card holder” on page 122), LED information signs can be designed according to needs. Illuminated signal elements and the customisable LED pilot light round off the range.

### SCHUKO® design and glass cover

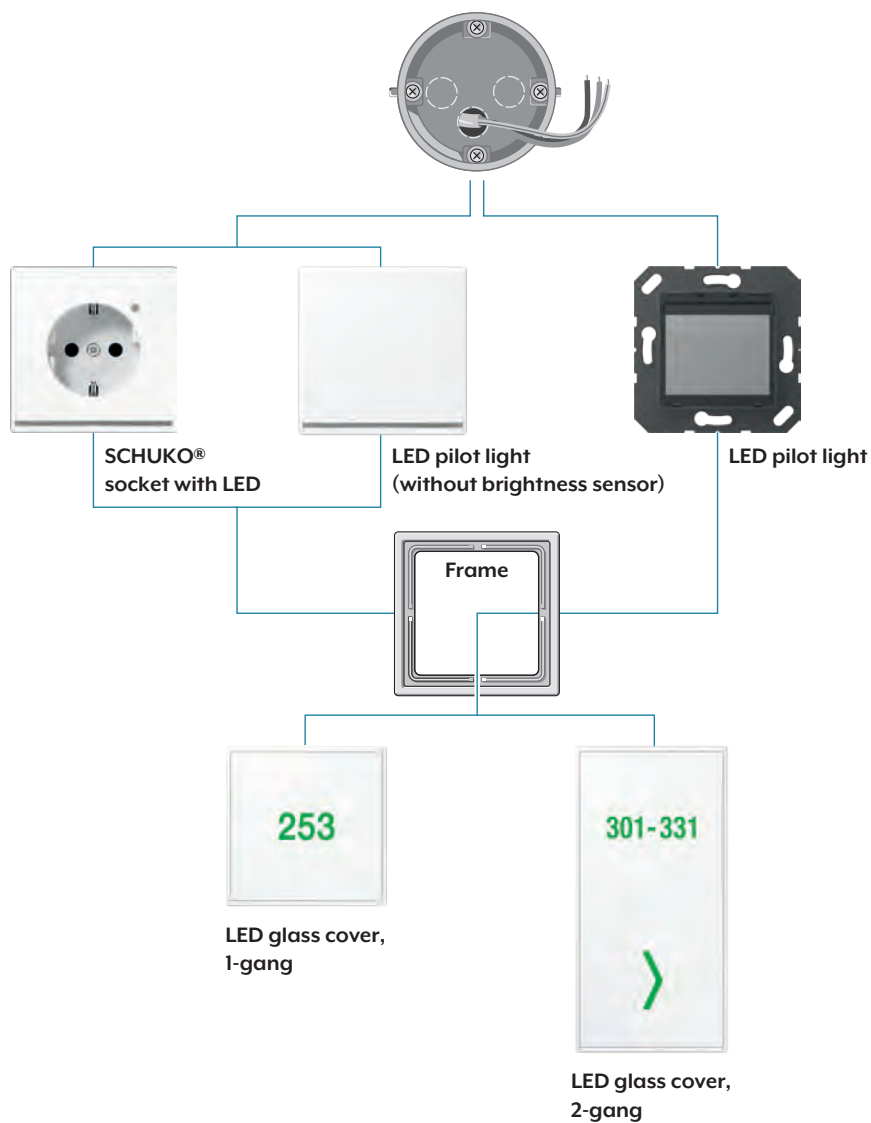

## 8.1 SCHUKO® and glass cover overview

INSERTS	RANGE	REFERENCE NUMBER
SCHUKO® socket with LED pilot light, integrated brightness sensor and increased contact protection	A	A 1520-O .. LNW
	LS	.. 1520-O .. LNW
SCHUKO® socket with LED pilot light and integrated increased contact protection	LS	.. 520-O .. LEDW
		.. 2520-O .. LEDW
LED pilot light with integrated brightness sensor	A	A 1539-O .. LNW
	LS	.. 1539-O .. LNW
LED pilot light without brightness sensor	A	A 1539-OO .. LNW
	LS	.. 1539-OO .. LNW
LED pilot light		LED KO6 TX 24

ATTACHMENTS	RANGE	REFERENCE NUMBER
LED glass cover, 1-gang*	A	A CU KO6 TX ..
	LS	LS CU KO6 TX ..
LED glass cover, 2-gang*	LS	LS CU KO6 TX-2 ..

\* The LED glass covers can be individually labelled. The order must be placed together with the individual labelling order from the Graphic Tool (<https://www.jung.de/en/2292/service/graphic-tool/>).

### LED pilot lights design

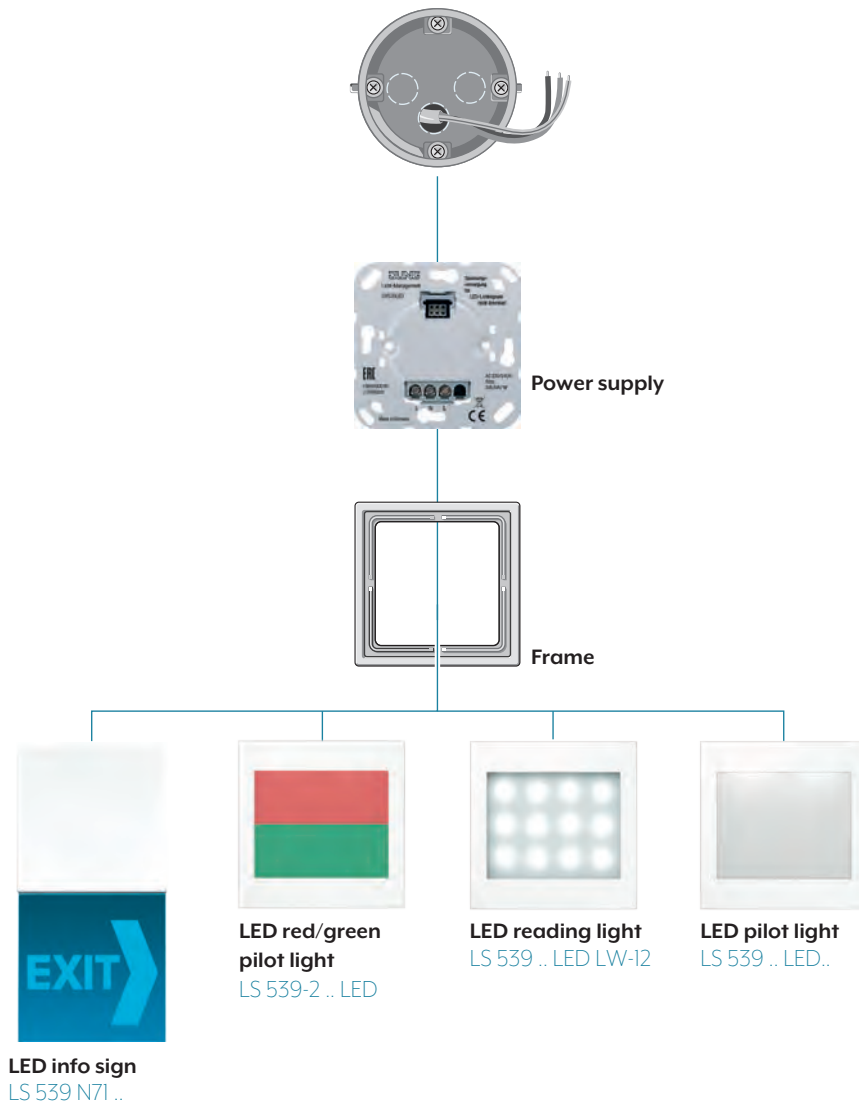

## 8.2 Overview of LED pilot lights

<b>INSERTS</b>	<b>REFERENCE NUMBER</b>	
Power supply		SV 539 LED
		SV 539-948 LED

<b>ATTACHMENTS</b>	<b>RANGE</b>	<b>REFERENCE NUMBER</b>
LED pilot light "Information" with RGB LEDs	LS	LS 539 N71 .. RGB
		.. 2539 N71 .. RGB
LED pilot light "Information" with blue LEDs	LS	LS 539 N71 .. LED B
		.. 2539 N71 .. LED B
LED pilot light "Information" with white LEDs	LS	LS 539 N71 .. LED W
		.. 2539 N71 .. LED W
LED pilot light with traffic light function red at the top, green at the bottom, can be controlled separately	LS	LS 539-2 .. LED RG
		.. 2539-2 .. LED RG
LED reading light with 12 white LEDs	LS	LS 539 .. LED LW-12
		.. 2539 .. LED LW-12
LED pilot light with white + blue LEDs	LS	LS 539 .. LEDWB
		.. 2539 .. LEDWB
LED pilot light with RGB LEDs	LS	LS 539 .. RGB
		.. 2539 .. RGB ..

## 8.3 SCHUKO® socket with LED floor pilot light

JUNG has optimised the SCHUKO® socket with pilot light. The light emission has been further developed with the LED lighting now integrated flush into the design cover.

An optional brightness sensor avoids unnecessary energy consumption. The white LED light (colour temperature 4,000 K) shines in a defined downward beam when required. This guarantees glare-free orientation at night without having to switch on the main lighting.

With availability in the A and LS ranges, a wide range of options is available in the hotel's own design concept. With an installation height of 30 cm, the beam angle (approx. 52°) results in a light field width of 20 centimetres (measured from the wall into the room).

### 8.3.1 Inserts

The various SCHUKO® socket inserts with LED floor pilot light are mounted in a wall box according to DIN 49073.

#### A / AS RANGE



MATERIAL	COLOUR	REF. NO.
Thermoplastic (breakproof) high-gloss	ivory	A 1520-O LNW
	white	A 1520-O WW LNW
MATERIAL	COLOUR	REF. NO.
Thermoplastic (breakproof) lacquered	aluminium	A 1520-O AL LNW
	champagne	A 1520-O CH LNW
	mocha	A 1520-O MO LNW
	matt anthracite	A 1520-O ANM LNW

(with integrated brightness sensor and integrated increased contact protection)

#### LS RANGE



MATERIAL	COLOUR	REF. NO.
Thermoplastic (breakproof) high-gloss	ivory	LS 1520-O LNW
	white	LS 1520-O WW LNW
	light grey	LS 1520-O LG LNW
	black	LS 1520-O SW LNW
MATERIAL	COLOUR	REF. NO.
Lacquered metal versions	aluminium	AL 1520-O LNW
	stainless steel	ES 1520-O LNW
	anthracite	AL 1520-O AN LNW
	dark	AL 1520-O D LNW
	classic brass	ME 1520-O C LNW
	antique brass	ME 1520-O AT LNW

(with integrated brightness sensor and integrated increased contact protection)

### 8.3.2 Connection

The different SCHUKO® socket inserts with LED floor pilot light have integrated increased contact protection. For the inserts ..1520 .. white LEDs with a colour temperature of 4,000 K are installed. The power consumption is 0.3 W in standby and 0.5 W in operation. The support ring, claws and claw screws are integrated via earth rail into the protective measure.

The installation of the SCHUKO® sockets with LED floor pilot light requires the use of a deep wall box. All inserts have spring terminals for rigid conductors up to 2.5 mm<sup>2</sup> and are supplied with connection terminals according to DIN VDE 0620. The LED lamps in the inserts ..1520 ... are permanently integrated.

## 8.4 LED pilot light with integrated brightness sensor

In addition to the SCHUKO® sockets, the LED floor pilot lights have also been further developed. JUNG also provides an LED floor pilot light integrated flush into the design cover here. The neutral white light of 4,000 K radiates downwards in a defined light beam and thus provides glare-free orientation points in the dark. The LED floor pilot lights are available with optional brightness sensor in the A and LS ranges. In this way, the LED floor pilot lights blend in perfectly with the individual design concept of the hotel.

### 8.4.1 Inserts

The various LED floor pilot light inserts with optional integrated brightness sensor are mounted in a wall box according to DIN 49073.

#### A / AS RANGE



MATERIAL	COLOUR	REF. NO.
Thermoplastic (breakproof)	ivory	A 1539-O LNW
high-gloss	white	A 1539-O WW LNW
	black	A 1539-O SW LNW

MATERIAL	COLOUR	REF. NO.
Thermoplastic (breakproof)	aluminium	A 1539-O AL LNW
lacquered	champagne	A 1539-O CH LNW
	mocha	A 1539-O MO LNW
	matt anthracite	A 1539-O ANM LNW

(with integrated brightness sensor)

#### A / AS RANGE



MATERIAL	COLOUR	REF. NO.
Thermoplastic (breakproof)	ivory	A 1539-OO LNW
high-gloss	white	A 1539-OO WW LNW

MATERIAL	COLOUR	REF. NO.
Thermoplastic (breakproof)	aluminium	A 1539-OO AL LNW
lacquered	champagne	A 1539-OO CH LNW
	mocha	A 1539-OO MO LNW
	matt anthracite	A 1539-OO ANM LNW

(without integrated brightness sensor)



**LS RANGE**

MATERIAL	COLOUR	REF. NO.
Thermoplastic (breakproof) high-gloss	ivory	LS 1539-O LNW
	white	LS 1539-O WW LNW
	light grey	LS 1539-O LG LNW
	black	LS 1539-O SW LNW

MATERIAL	COLOUR	REF. NO.
Lacquered metal versions	aluminium	AL 1539-O LNW
	stainless steel	ES 1539-O LNW
	anthracite	AL 1539-O AN LNW
	dark	AL 1539-O D LNW
	classic brass	ME 1539-O C LNW
	antique brass	ME 1539-O AT LNW

(with integrated brightness sensor)

**LS RANGE**

MATERIAL	COLOUR	REF. NO.
Thermoplastic (breakproof) high-gloss	ivory	LS 1539-OO LNW
	white	LS 1539-OO WW LNW
	light grey	LS 1539-OO LG LNW
	black	LS 1539-OO SW LNW

MATERIAL	COLOUR	REF. NO.
Lacquered metal versions	aluminium	AL 1539-OO LNW
	stainless steel	ES 1539-OO LNW
	anthracite	AL 1539-OO AN LNW
	dark	AL 1539-OO D LNW
	classic brass	ME 1539-OO C LNW
	antique brass	ME 1539-OO AT LNW

(without integrated brightness sensor)

### 8.4.2 Connection

The different inserts of the LED floor pilot light have spring terminals for rigid conductors up to 2.5 mm<sup>2</sup> and are supplied with connection terminals according to DIN VDE 0620.

The LED lamps with a colour temperature of 4,000 K are permanently integrated into the inserts .. 1539 .. The power consumption is 0.3 W in standby and 0.5 W in operation. The support ring, claws and claw screws are integrated via earth rail into the protective measure.

When installing the LED floor pilot light based on the principle of the SCHUKO® socket, it is necessary to use a deep wall box. All inserts have spring terminals for rigid conductors up to 2.5 mm<sup>2</sup> and are supplied with connection terminals according to DIN VDE 0620. The LED lamps in the inserts .. 1520 .. are permanently integrated. Only the lighting rail in the insert .. 520 .. can be replaced. The connection to 230 V ~ AC is made here using two flexible cables (brown/blue) of approx. 220 mm length directly or via an external switch.

## 8.5 LED info sign

In public areas of a hotel, it is important to mark certain orientation points in an intuitively understandable way and to make them visible from afar. The LED info signs are the most eye-catching way to mark important way points. The inserted Plexiglas® pane of 71 x 71 mm can be individually labelled. The most important symbols are provided directly for selection in the PDF order form ([www.jung.de/gt](http://www.jung.de/gt)).

Further customisations are possible using the JUNG Graphic Tool (<https://www.jung.de/en/2292/service/graphic-tool/>).

The Plexiglas® pane can be illuminated in blue or white. The colours red, blue, green, violet, yellow, light blue or white can be programmed via a 3-pole DIP switch for the RGB version.

### 8.5.1 Inserts

The LED pilot lights need an external power supply. Using the following inserts, all LED pilot lights – with the exception of the LED glass covers – are supplied with power. The inserts are mounted in a wall box according to DIN 49073.

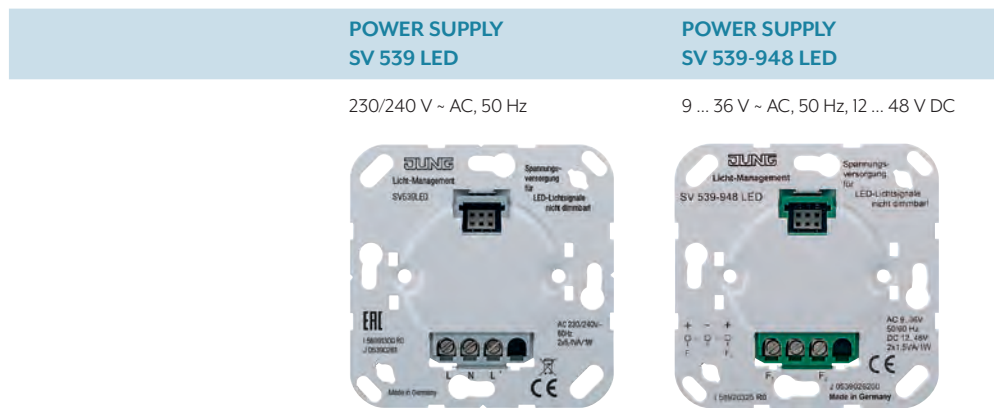

CONNECTION AND FUNCTIONS		
dimmmable		no
Rated voltage		
AC operation	230/240 V ~ AC, 50 Hz	9 ... 36 V ~ AC, 50 Hz
DC operation	no	12 ... 48 V DC
Ambient temperature		0 ... +40 °C
Terminals	L, N, L'	F1, L, F2
Protection class (for mounted attachment)		 or IP20
Power consumption (for mounted attachment)		
AC operation	typical 2 x 5.4 VA / 2 x 1.0 W	2 x 1.5 VA
DC operation	no	2 x 1.0 W
Connection	Screw terminals	
max. usable wire cross-section	2 x 2.5 mm <sup>2</sup> or 1 x 4 mm <sup>2</sup>	
Function	only for the power supply of the LED pilot lights ref. no. .. 539 ..	

## 8.5.2 Attachments

## LED INFO SIGN RGB



MATERIAL	COLOUR	REF. NO.
Metal versions (* lacquered aluminium)	white *	LS 539 N7IWW RGB
	light grey *	LS 539 N7ILG RGB
	black *	LS 539 N7ISW RGB
	aluminium	AL 2539 N7I RGB
	stainless steel *	ES 2539 N7I RGB
	anthracite *	AL 2539 N7IAN RGB

## LED INFO SIGN BLUE



MATERIAL	COLOUR	REF. NO.
Metal versions (* lacquered aluminium)	white *	LS 539 N7IWWLED B
	light grey *	LS 539 N7ILGLED B
	black *	LS 539 N7ISWLED B
	aluminium	AL 2539 N7ILED B
	stainless steel *	ES 2539 N7ILED B
	anthracite *	AL 2539 N7IAN LED B

## LED INFO SIGN WHITE



MATERIAL	COLOUR	REF. NO.
Metal versions (* lacquered aluminium)	white *	LS 539 N7IWWLED W
	light grey *	LS 539 N7ILGLED W
	black *	LS 539 N7ISWLED W
	aluminium	AL 2539 N7ILED W
	stainless steel *	ES 2539 N7ILED W
	anthracite *	AL 2539 N7IAN LED W

### 8.5.3 Connection

The frame ref. no. LS 981 .. (1 to 5-gang) or AL/ES/GCR 2981 (1 to 5-gang) is always required for mounting on the power supply.

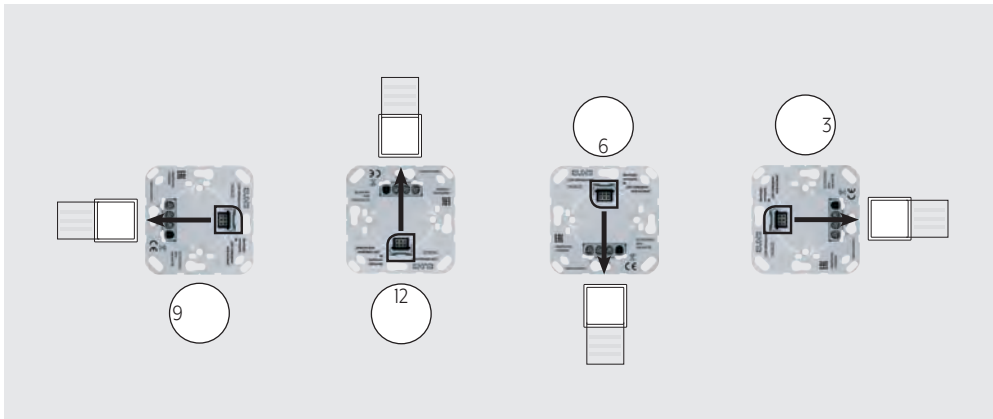

1. Decide in which direction the info sign should point.

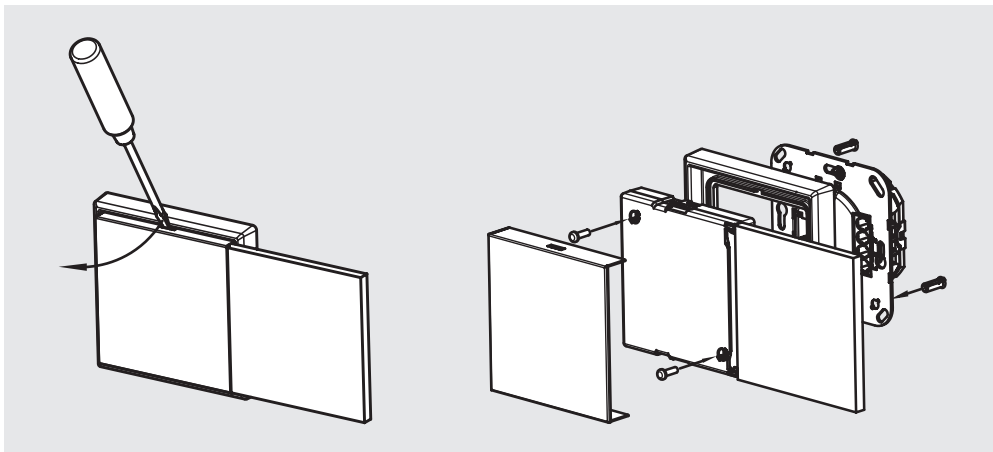

2. Loosen the cover of the attachment by levering into the small opening with a flat blade screwdriver.
3. Guide the plastic threaded sleeve through the holes provided in the flush-mounted insert.

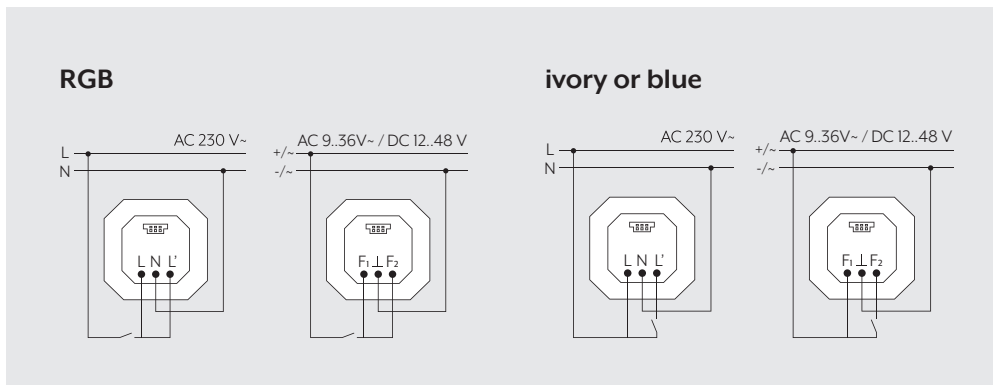

4. Connect the flush-mounted power supply insert according to the desired use of the attachment.

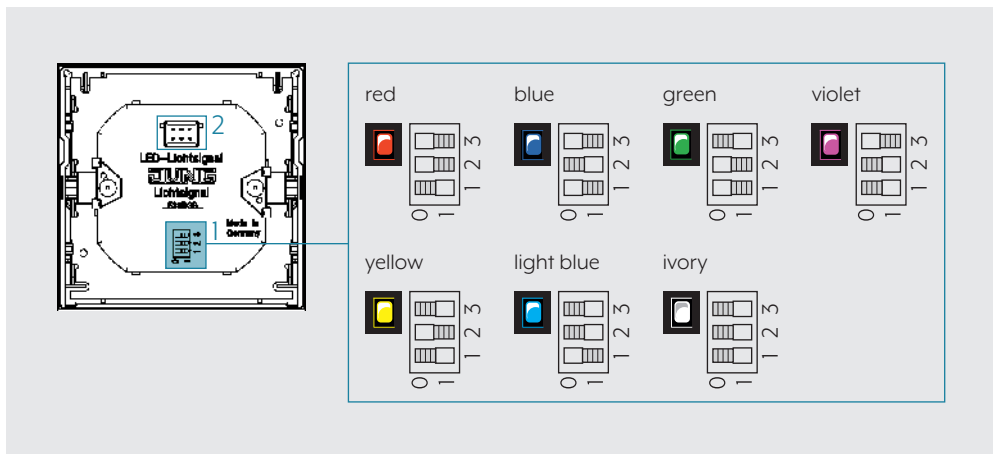

5. For LED pilot light with RGB colours: Set the colours on the back of the 3-pole DIP switch (1).
6. Mount the flush-mounted power supply insert in the wall box according to the required position for alignment of the information sign.
7. Mount the frame on the insert.
8. Insert the labelled information sign at the desired position.
9. Connect the electrical connection of the attachment to the plug (2).
10. Secure the attachment with the screws in two opposite corners.
11. Put the cover on the attachment.

## 8.6 LED pilot light with traffic light function

The LED pilot light with traffic light function is also an efficient control and information element in the hotel sector. It can be used as an access control in room service, whereby the guest in the room can select the visual display for the corridor. In addition, the LED pilot light can prevent unwanted disturbance in conference rooms. The red and green indicators can be controlled separately. The labelling is done with foil by JUNG and can be individually designed using the JUNG Graphic Tool (<https://www.jung.de/en/2292/service/graphic-tool/>).

### 8.6.1 Inserts

An overview of the different power supply inserts can be found in chapter "8.5.1 Inserts" on page 147.

### 8.6.2 Attachments

#### LS RANGE



MATERIAL	COLOUR	REF. NO.
Metal versions (* lacquered aluminium)	white *	LS 539-2 WW LED RG
	light grey *	LS 539-2 LG LED RG
	black *	LS 539-2 SW LED RG
	aluminium	AL 2539-2 LED RG
	stainless steel *	ES 2539-2 LED RG
	anthracite *	AL 2539-2 AN LED RG
	classic brass	ME 2539-2 LED RG C
	antique brass	ME 2539-2 LED RG AT

### 8.6.3 Connection

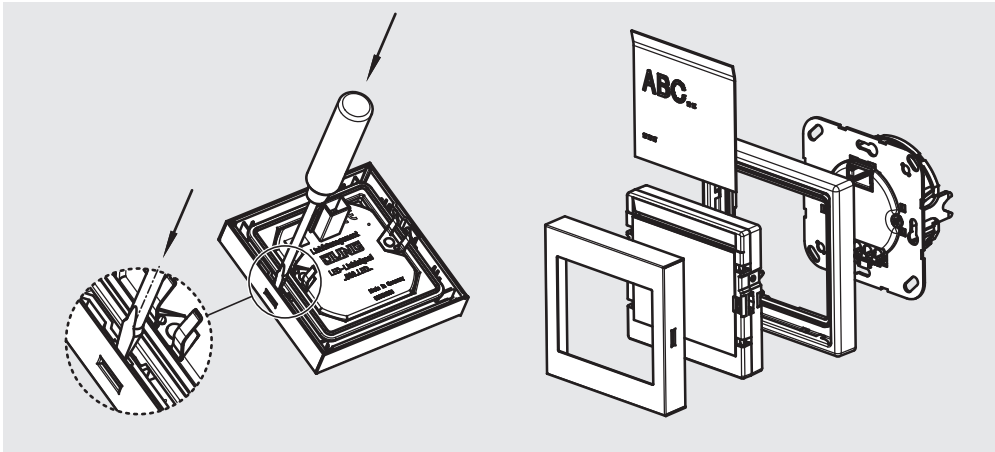

1. Open the LED pilot light by carefully loosening the connection between the frame and the attachment with a flat blade screwdriver.

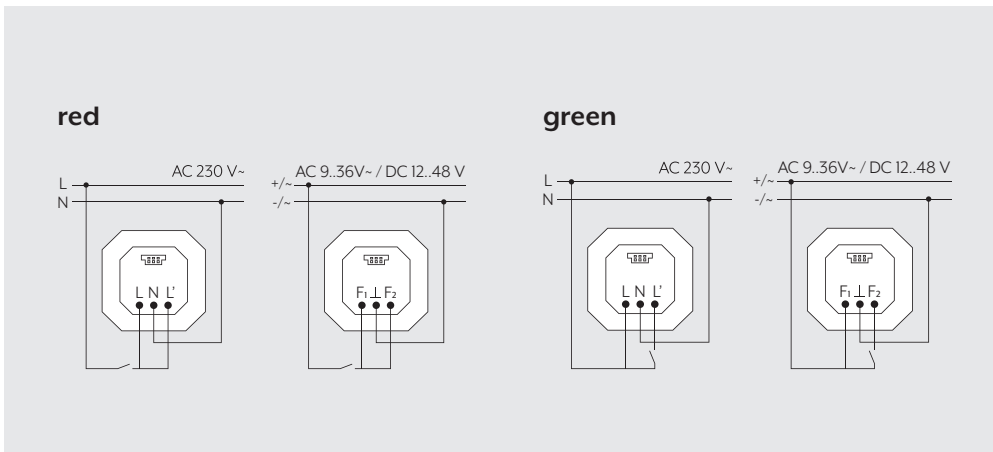

2. Connect the flush-mounted power supply insert in a deep wall box according to the desired use of the attachment.
3. Mount the frame on the insert.

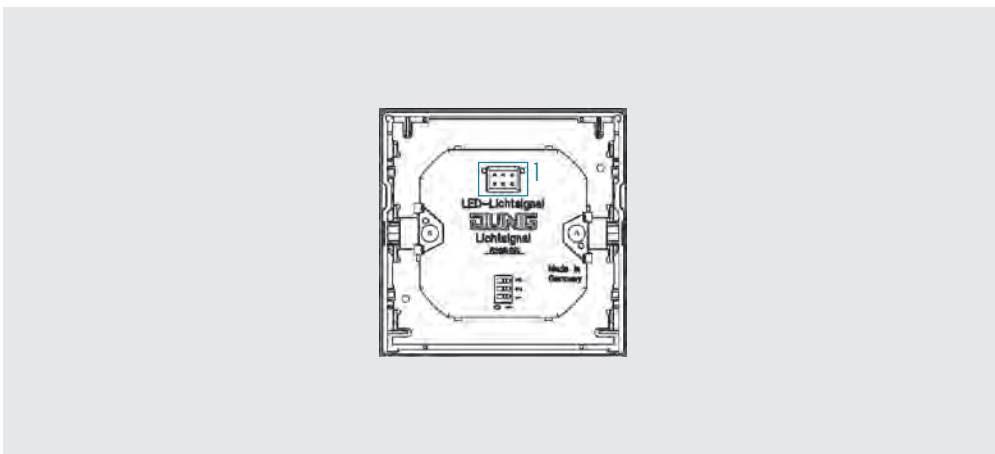

4. Connect the electrical connection of the attachment to the plug (1).
5. Slide the labelling foil into the provided holder.
6. Put the cover on the attachment.



## 8.7 LED reading light

The step lighting in a hotel is a safety-related issue. The LED reading light from JUNG is ideal for this purpose. It can be switched to two brightness levels via a 2-gang switch. All 12 LEDs are switched on for maximum brightness. The discreet reading light can be combined with all frames of the LS range.

### 8.7.1 Inserts

An overview of the different power supply inserts can be found in chapter "8.2 Overview of LED pilot lights" on page 141.

### 8.7.2 Attachments

#### LS RANGE



MATERIAL	COLOUR	REF. NO.
Metal versions (* lacquered aluminium)	white *	LS 539 WW LED LW-12
	light grey *	LS 539 LG LED LW-12
	black *	LS 539 SW LED LW-12
	aluminium	AL 2539 LED LW-12
	stainless steel *	ES 2539 LED LW-12
	anthracite *	AL 2539 AN LED LW-12

### 8.7.3 Connection

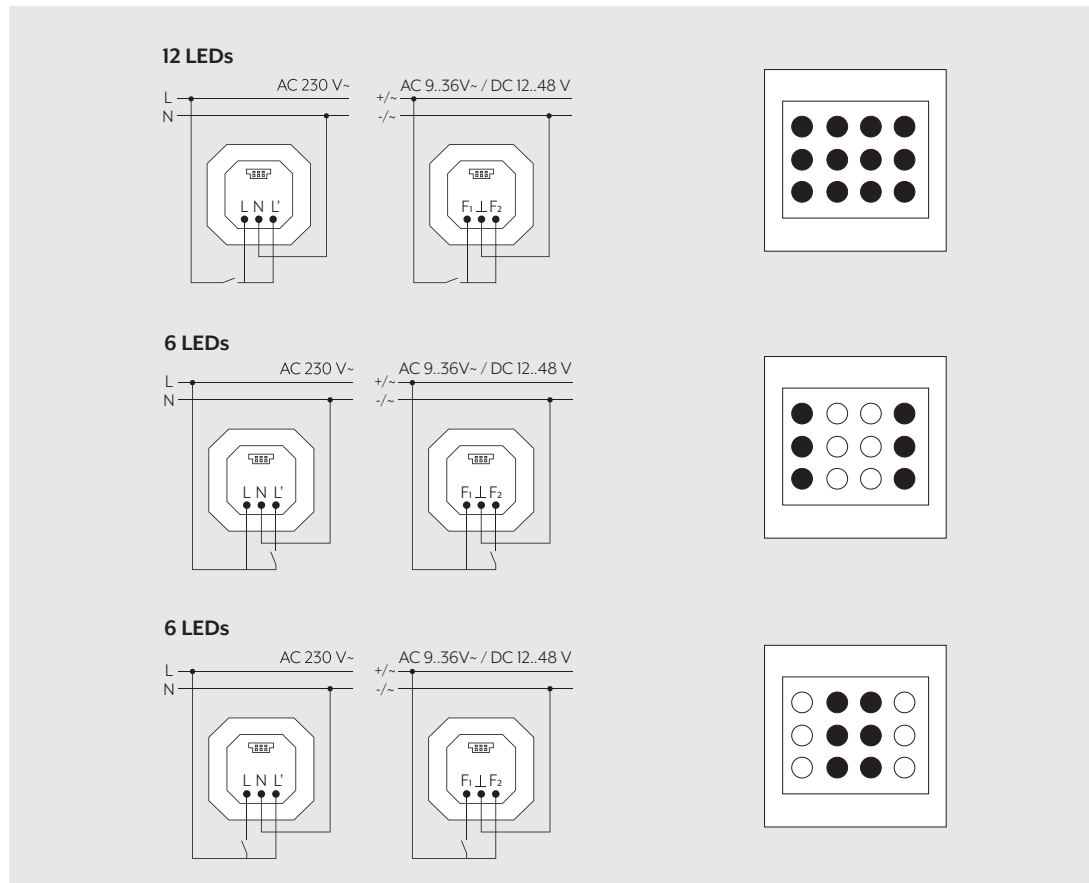

1. Connect the flush-mounted power supply insert in a deep wall box according to the desired use of the attachment.

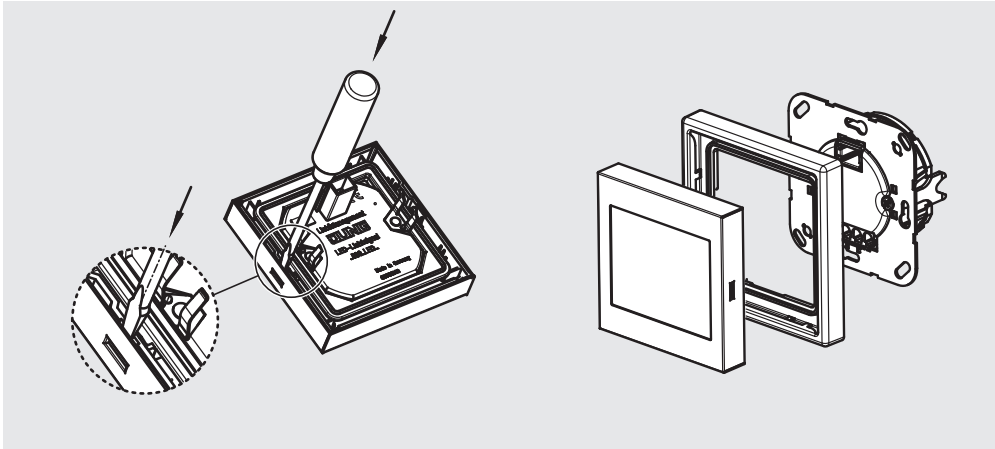

2. Open the LED pilot light by carefully loosening the connection between the frame and the attachment with a flat blade screwdriver.
3. Mount the frame on the insert.

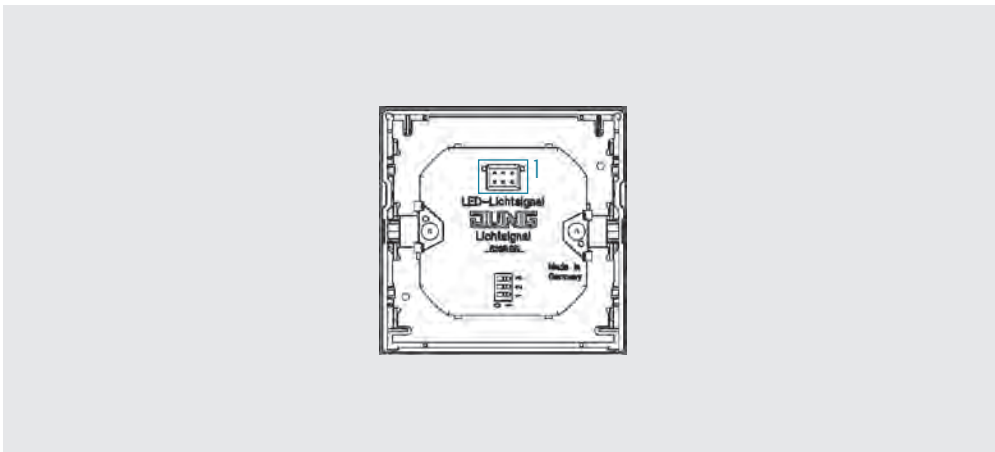

4. Connect the electrical connection of the attachment to the plug (I).
5. Put the cover on the attachment.

## 8.8 LED pilot light RGB, blue, white

The LED pilot light is suitable for discreet orientation lighting in continuous operation. Depending on the connection, it is backlit in blue or white. Programming the RGB attachment in red, blue, violet, yellow, light blue and white is also possible via the DIP switch of the power supply insert. A traffic light function in red, yellow and green is also possible.

The LED pilot light can be installed as a selective light signal and can be individually labelled. The labelling of the transparent foil is performed using the JUNG Graphic Tool (<https://www.jung.de/en/2292/service/graphic-tool/>).

The LED pilot light can be combined with all frames of the LS range.

### 8.8.1 Inserts

An overview of the different power supply inserts can be found in chapter "8.5.1 Inserts" on page 147.

### 8.8.2 Attachments

LED PILOT LIGHT RGB			
	MATERIAL	COLOUR	REF. NO.
	Metal versions (* lacquered aluminium)	white *	LS 539 WW RGB
		light grey *	LS 539 LG RGB
		black *	LS 539 SW RGB
		aluminium	AL 2539 RGB
		stainless steel *	ES 2539 RGB
		anthracite *	AL 2539 AN RGB
		dark *	AL 2539 RGB D
		classic brass (lacquered)	ME 2539 RGB C
		antique brass (lacquered)	ME 2539 RGB AT
		LED PILOT LIGHT, BLUE / WHITE	
	MATERIAL	COLOUR	REF. NO.
	Metal versions (* lacquered aluminium)	white *	LS 539 WW LEDWB
		light grey *	LS 539 LG LEDWB
		black *	LS 539 SW LEDWB
		aluminium	AL 2539 LEDWB
		stainless steel *	ES 2539 LEDWB
		anthracite *	AL 2539 AN LEDWB
		classic brass (lacquered)	ME 2539 LEDWB C
		antique brass (lacquered)	ME 2539 LED WB AT

### 8.8.3 Connection

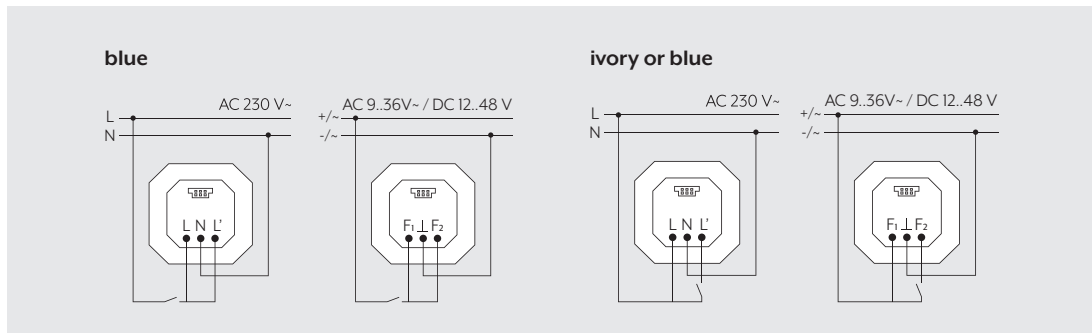

1. Connect the flush-mounted power supply insert in a deep wall box according to the desired use of the attachment.

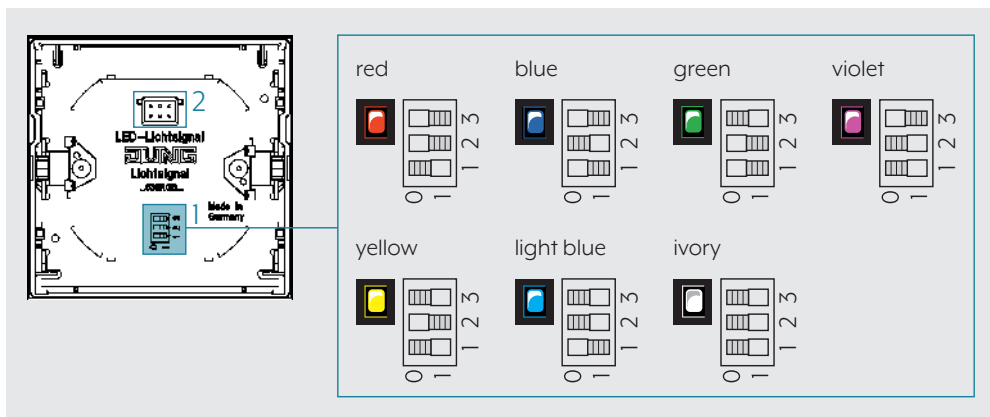

2. Set the colours on the back of the 3-pole DIP switch (1) for programming the LED pilot light with RGB colours.
3. The wiring L, L' and N or F<sub>1</sub>, F<sub>2</sub> and  $\underline{L}$  is necessary for programming a traffic light function.
4. Then set the switches on the rear side of the 3-pole DIP switch (1) to 1 0 1.
  - The following traffic light functions can be programmed:
 

only L' or F <sub>2</sub> energised	red
L and L' or F <sub>1</sub> and F <sub>2</sub> energised	yellow
only L or F <sub>1</sub> energised	green

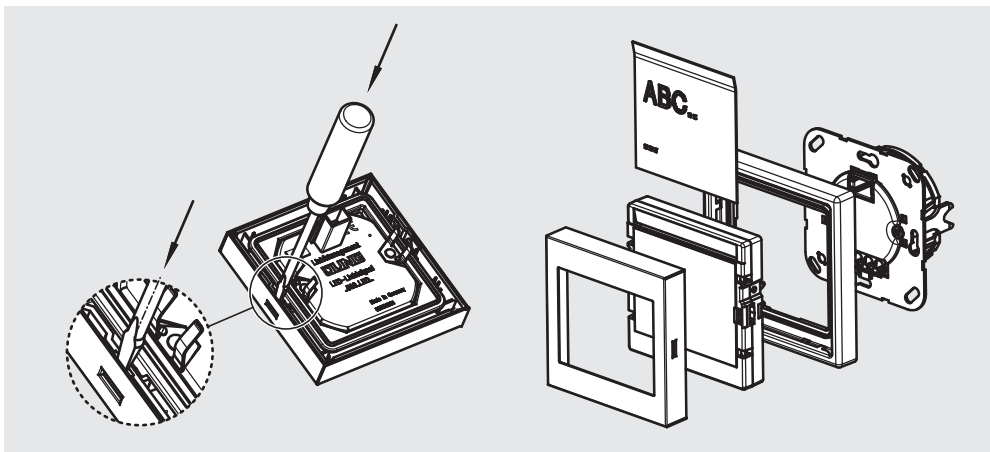

5. Open the LED pilot light by carefully loosening the connection between the frame and the attachment with a flat blade screwdriver.
6. Mount the frame on the insert.
7. Connect the electrical connection of the attachment to the plug (2).
8. Slide the optional labelling foil into the provided holder.
9. Put the cover on the attachment.

## 8.9 Plug & Light as pilot lights

The innovative Plug & Light lighting design also enables use as orientation and information lighting in a hotel room.

### PLUG & LIGHT LED FLOODLIGHTS



#### DESCRIPTION

The Plug & Light floodlight is characterised by its flat design. Its design is reminiscent of a classic switch.

The light attachments from Insta guarantee optimum light distribution over the entire dimming range and can be rotated 360° without any stops.

In the evening hours or for the night, the guest can turn the floodlight downwards and thus create a discreet orientation light from a glare-free working light or picture lighting.

Further information about devices, reference numbers and installation options can be found in chapter "12. Innovation: Plug & Light" on page 240.

## 8.10 LED glass cover

The stylish LED pilot lights with real glass cover stand out due to their wide range of design options. Different inscriptions can be made using the JUNG Graphic Tool (<https://www.jung.de/en/2292/service/graphic-tool/>) for different orientation indications. Safe, intuitive orientation in modern hotels is ensured with individual settings of the light colours. For example, different switching states with different labels can indicate the occupancy situation in conference rooms. The discreet design of the real glass covers is designed to match the JUNG A and LS ranges.

### 8.10.1 Insert

The insert for the LED pilot light is designed for use in dry indoor areas. Installation in a wall box according to DIN 49073. The backlighting in white, red, green or orange can be controlled as a colour change via a separate 2-gang switch, for example ref. no.: 505 U or 505 KO5 VEU M 24 (not included in the scope of delivery).

#### LED INSERT



LED KO6 TX24

#### CONNECTION AND FUNCTIONS

dimnable	no
Rated voltage	24 V DC SELV $\pm 10\%$
Ambient temperature	-5 ... +45 °C
Protection class (for mounted attachment)	⊕
Rated power	< 1.5 W
Connection	Terminal Wago PicoMax 3.5 Type 2091-II24
max. usable wire cross-section	0.5 ... 1.5 mm <sup>2</sup>
Function	for backlighting of the covers A CU KO6 TX .. LS CU KO 6 TX ...

## 8.10.2 Attachments

The LED pilot lights made of real glass, which are unique on the market, are characterised by a high-quality appearance. The order for individual labelling is made using the JUNG Graphic Tool (<https://www.jung.de/en/2292/service/graphic-tool/>). For larger projects with more than 200 components, further customisations such as special colours for the glass panes and individual lighting are possible.

### LED glass cover, 1-gang

#### A RANGE



COLOUR	REF. NO.
white 	A CU KO6 TX WW
black 	A CU KO6 TX SW

#### LS RANGE



COLOUR	REF. NO.
white 	LS CU KO6 TX WW
black 	LS CU KO6 TX SW

### LED glass cover, 2-gang

#### LS RANGE



COLOUR	REF. NO.
white 	LS CU KO6 TX-2 WW
black 	LS CU KO6 TX-2 SW

 : Laser engraving possible



### 8.10.3 Connection

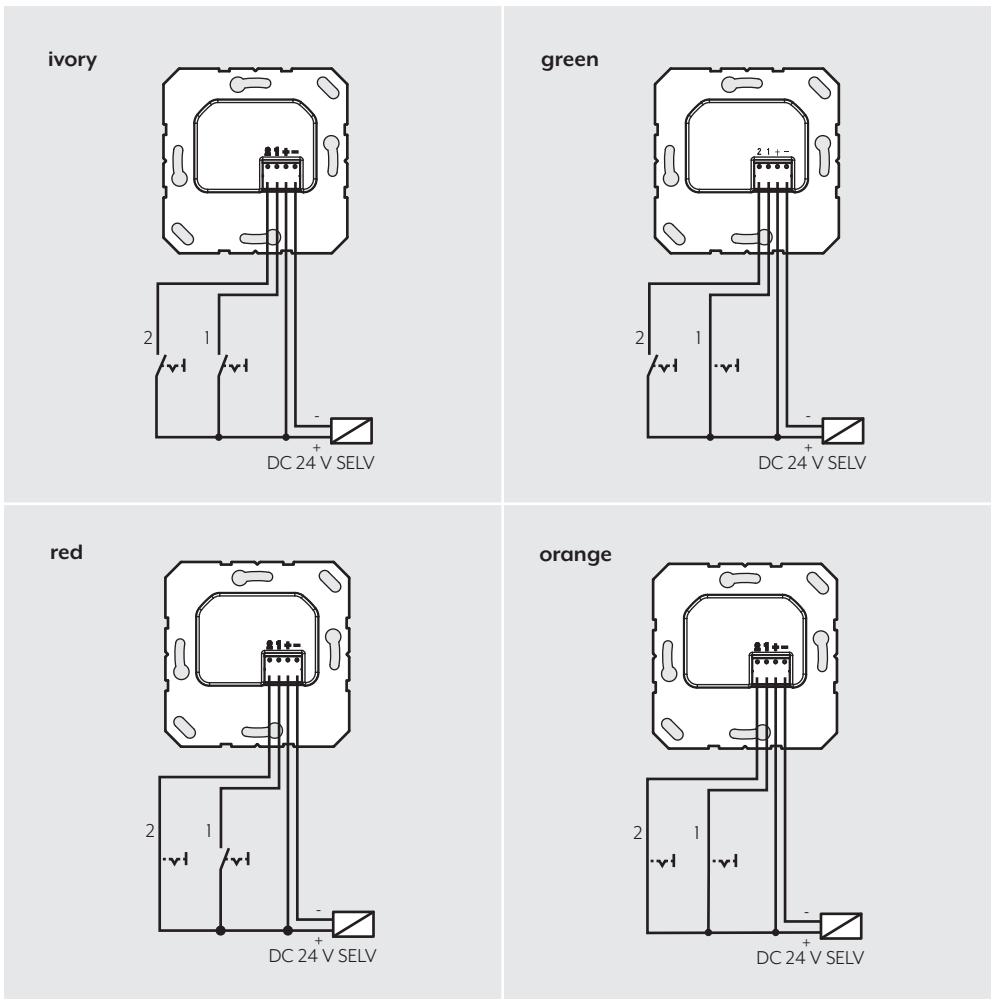

1. Mount the insert according to the desired colour in the wall box.

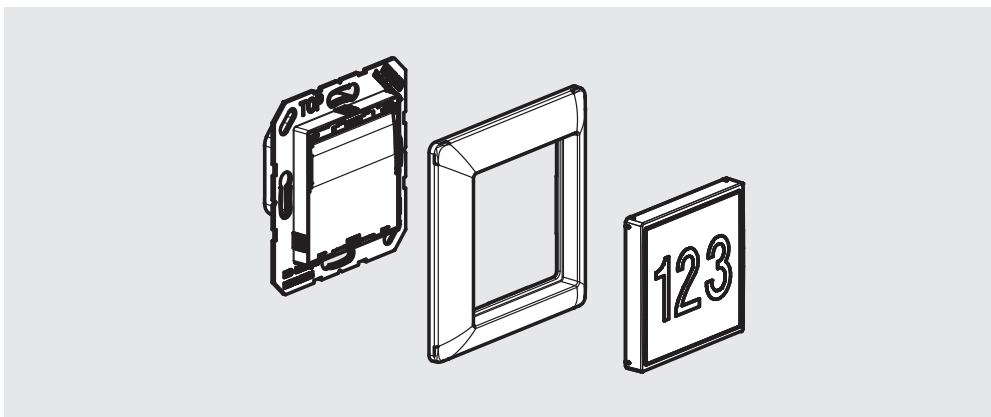

2. Mount the frame.
3. Put the real glass cover on the insert.



<b>9. AUTOMATIC LIGHT</b>	
<b>9.1 DEVICE OVERVIEW</b>	<b>165</b>
<b>9.2 OPERATING MODES AND FUNCTIONS</b>	<b>166</b>
<b>9.3 INSERTS</b>	<b>168</b>
9.3.1 Switch inserts	168
9.3.2 Installation and electrical connection	170
9.3.3 Dimming inserts	172
9.3.4 Installation and electrical connection	173
9.3.5 Expansion inserts	175
9.3.6 Installation and electrical connection	177
<b>9.4 ATTACHMENTS</b>	<b>180</b>
9.4.1 Standard automatic switch 1.1 m	180
9.4.2 Standard automatic switch 2.2 m	181
9.4.3 Installation and electrical connection of the Standard automatic switches 1.1 m and 2.2 m	182
9.4.4 Universal automatic switch 1.1 m	183
9.4.5 Universal automatic switch 2.2 m	184
9.4.6 Installation and electrical connection of the Universal automatic switches 1.1 m and 2.2 m	185
9.4.7 Mini Basic ceiling observer / presence detector / motion detector	187
9.4.8 Installation and electrical connection of ceiling observer / presence detector	188
<b>9.5 SETTING UP DETECTION FIELDS</b>	<b>193</b>
9.5.1 Adjustment of the parameters for automatic switches / ceiling observers / presence detectors	197
<b>9.6 ACCESSORIES</b>	<b>198</b>
<b>9.7 KNX AUTOMATIC SWITCHES AND PRESENCE DETECTORS</b>	<b>199</b>
9.7.1 Device Overview	200
9.7.2 KNX bus coupling unit insert	201
9.7.3 Installation and electrical connection of KNX bus coupling unit 3	202
9.7.4 KNX automatic switch 1.1 m Standard	203
9.7.5 KNX automatic switch 1.1 m Universal	204
9.7.6 Installation and electrical connection of KNX automatic switch 1.1 m	205
9.7.7 KNX automatic switch 2.2 m Standard	207
9.7.8 KNX automatic switch 2.2 m Universal	208
9.7.9 Installation and electrical connection of KNX automatic switch 2.2 m	209
9.7.10 KNX ceiling observer / presence detector	210
9.7.11 Installation and electrical connection of KNX presence detector mini and KNX brightness controller mini	212
9.7.12 Installation and electrical connection of KNX presence detector / ceiling observer	214
<b>9.8 MOTION DETECTOR MINI BASIC</b>	<b>215</b>
9.8.1 Use Case 1 – Guest room	215
9.8.2 Use Case 2 – Presence monitoring with motion detector – Luxury hotel room	217

## 9. Automatic Light

Different lighting requirements have to be met in the public areas of a comfortable hotel. In addition to orientation and information lighting throughout the building, corridors and car parks rely on additional light. The JUNG Light Management provides different components that automatically switch the light when required and thus ensure a safe path through the entire hotel and a responsible use of resources.

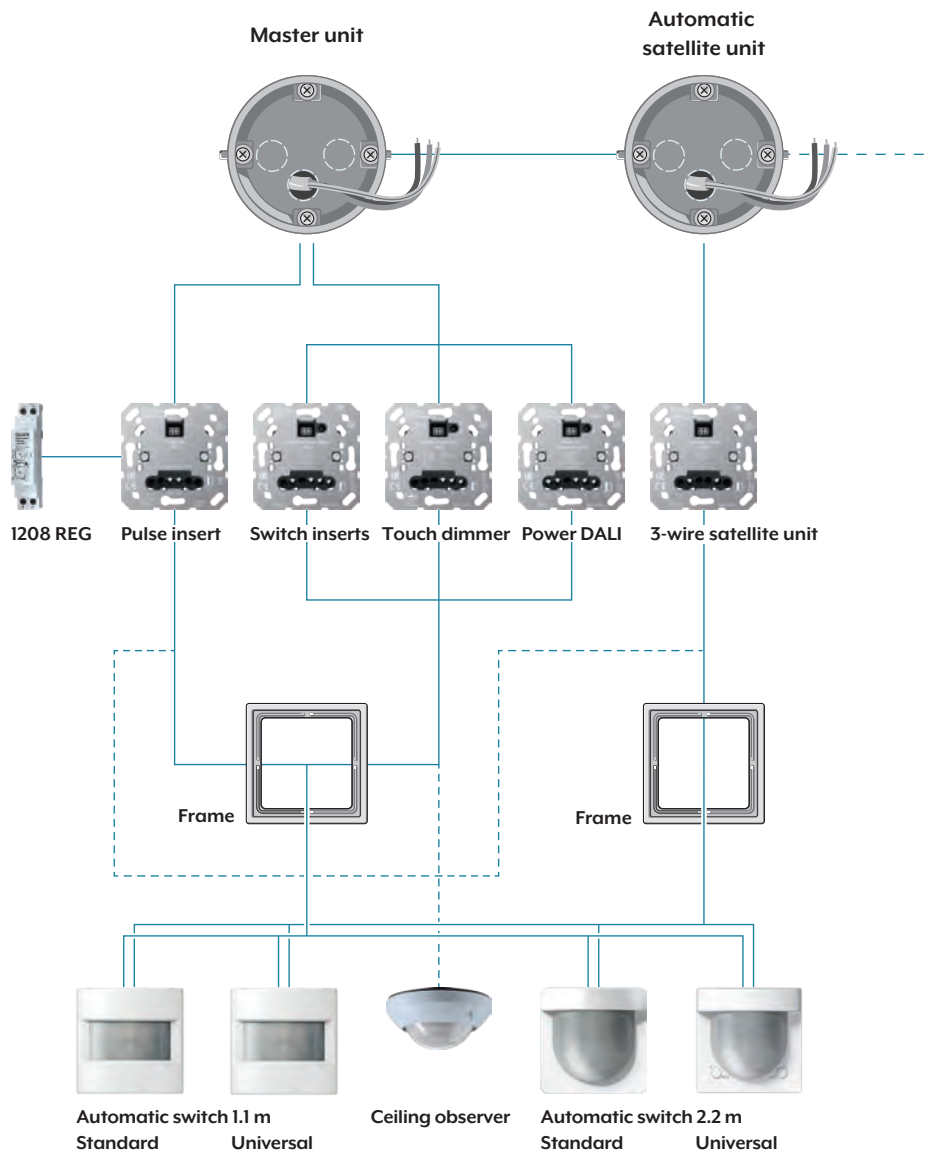

## 9.1 Device Overview

<b>INSERTS</b>	<b>REFERENCE NUMBER</b>
Relay switch insert 1-channel	1701 SE
Relay switch insert 2-channel	1702 SE
Electronic switch insert 1-channel	1704 ESE
Standard touch dimmer LED	1710 DE
Universal touch dimmer LED	1711 DE
2-wire satellite unit	1720 NE
3-wire satellite unit	1723 NE
Power DALI push-button controller TW	1713 DSTE
Pulse insert for rail mounting	1708 IE
	1208 REG

<b>ATTACHMENTS</b>	<b>RANGE</b>	<b>REFERENCE NUMBER</b>
Standard automatic switch 1.1 m		.. 17180 ..
Standard automatic switch 2.2 m	A LS	.. 17280 ..
Universal automatic switch 1.1 m	CD LS	.. 17181 ..
Universal automatic switch 2.2 m		.. 17281 ..
Ceiling observer/presence detector		DWPM 17360 ..
Ceiling observer / presence detector with integrated power section		DWPM K 360 ..

<b>ACCESSORIES</b>	<b>RANGE</b>	<b>REFERENCE NUMBER</b>
Sealing kit for automatic switch 2.2 m, to achieve protection level IP 44	A/AS CD/LS	AS A 50 DS AS CD 50 DS
Sealing gasket for automatic switch 1.1 m, to achieve protection level IP 44		551 WU
Protection cage		SK 180-90 WW
Surface-mounted housing		PM-KAPPE- ..

## 9.2 Operating modes and functions

JUNG provides various options for lighting areas of a comfortable hotel as required. Motion-dependent lighting control provides two areas of application that can be basically differentiated:

**Automatic switches** and **observers** are mainly designed to avoid dangerous situations in the dark. Transit zones such as stairs and corridors are illuminated in an energetically sensible way when movement is registered. In the bathroom, an automatic switch provides discreet indirect light at night without having to search for the light switch in the dark. The light switches off automatically after a programmed shut-off delay.

**Presence detectors** and **ceiling observers** are used for rooms where people spend longer periods of time and constant light is needed. These are public areas in the hotel such as conference rooms or the parking garage. In the area of housekeeping, presence detectors and ceiling monitors make work processes easier for the personnel. The light can be controlled manually, but there is no need to think about switching it off when leaving for example the utility room. In all cases, automatic switches and presence detectors optimise resource-saving energy use.

### OBSERVER OPERATING MODE

The load is switched depending on thermal movement and ambient brightness. The lighting cannot be switched off using a switch, push-button or radio networking.

### PRESENCE DETECTION OPERATING MODE

The load is switched depending on thermal movement and ambient brightness.

The lighting can be switched off using a 3-wire satellite unit, a push-button or radio networking. Switching on again by motion detection does not take place until after expiry of the shut-off delay. Motion-dependent lighting can be individually controlled with dimming inserts. The presence detection mode is adjusted easily and conveniently by smart phone via Bluetooth in the Clever Config app.

### CONTINUOUS ON FUNCTION

This function allows you to prevent the motion detector from detecting no presence for low-motion activities and switching off the lighting. Using the Clever Config app or a switch on the device, you can prevent the light from being switched off in relaxation rooms in the spa area.

### 0.5 - 5 HOURS CONTINUOUS ON FUNCTION

The load is switched on for a definable period of 0.5 to 5 hours until it is manually deactivated. Differently to "Continuous ON", the function is automatically terminated and changes to automatic mode ("AUTO" function).

### CONTINUOUS OFF FUNCTION

During film screenings or projector presentations, suddenly switching on lights is an avoidable disruptive factor. With this function, the load is switched off until the function is deactivated again via the Clever Config App or with a switch on the device.

### 0.5 - 5 HOURS CONTINUOUS OFF FUNCTION

Differently to "Continuous OFF", the load is automatically switched on again after a defined time. The device switches to automatic mode ("AUTO" function).

**PULSE MODE FUNCTION**

If presence is detected, the load is always activated only briefly (approx. 0.5 seconds) in pulse mode. Continuous movement detection results in repetition of the switch-on pulse at defined time intervals. Rooms that are not constantly used, such as bathrooms or guest toilets in the restaurant area, are thus effectively illuminated when in use.

**SWITCH-OFF PREWARNING FUNCTION**

At the end of a motion detection and after expiry of the shut-off delay, the lighting is not switched off immediately. The switch insert warns by flashing three times at intervals of 10 seconds. The dimming insert regulates the light and thus signals that the light will soon go out. The person present in the room can prevent the switch-off of the shut-off delay by moving again. While gathering all the utensils needed for housekeeping, the personnel are not surprised that the light suddenly goes out in the utility room without windows.

**ALARM MODE FUNCTION**

The alarm mode function is useful at closing times of the hotel. If the hotel is closed during the holiday of the owners, the automatic light in all or remote rooms can be programmed with the alarm mode function. Unwanted thermal movements cause the light to switch on and can deter burglars. Neighbouring residents can also be alerted to a burglary in this way.

**HOTEL LIGHT / PILOT LIGHT FUNCTION**

The convenience function switches the light in hotels between two brightness levels. The device must be combined with a dimming insert for this. If the corridor or staircase is permanently minimally lit for better orientation, the motion detector switches to a stored higher brightness value when it detects thermal movement. After expiry of the shut-off delay, the lighting is dimmed back to the brightness of the pilot lights.

**NIGHT LIGHT FUNCTION**

The light is switched on at a low brightness at programmable time intervals when movement is detected. The device must be combined with a dimming insert for this.

**CONSTANT LIGHT REGULATION FUNCTION**

Combined with a dimming insert and the 2-wire satellite unit centre plate (at terminal 1), the motion detector constantly measures the sum of artificial light and daylight. A desired brightness value is switched when a movement is detected and the value falls below the set switching threshold. The brightness in the room remains constant independently of the incidence of daylight. This comfortable illumination ensures the best possible light, for example in conference rooms, and results in the greatest possible energy savings.

**TIMER FUNCTION**

A schedule for the different functions can be created for each day of the week.

**LOCKING TIME**

If the motion detector switches off the light after expiry of the shut-off delay, a short locking time ensures that the motion detection is suppressed. This prevents the motion detector from registering the cooling lamps in the monitoring area as thermal movement and immediately switching them on again. The motion detectors automatically determine the required locking time between 0.3 to max. 3 seconds.

## 9.3 Inserts

The JUNG modular system enables the combination of different switch inserts, dimming inserts and optional add-ons such as satellite units, Power DALI or pulse inserts. All inserts are mounted in wall boxes according to DIN 49073.

### 9.3.1 Switch inserts

#### RELAY SWITCH INSERT 1-CHANNEL | 1701 SE

230 V ~ AC, 50/60 Hz

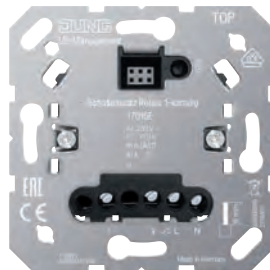

#### RELAY SWITCH INSERT 2-CHANNEL | 1702 SE

230 V ~ AC, 50/60 Hz



#### CONNECTION AND FUNCTIONS

Attachments	.. 17180 .. / .. 17280 .. / .. 17181 .. / .. 17281 .. / .. DWPM17360 ..	
Standby consumption	approx. 0.1 ... 0.5 W	
Switching current at 25 °C		
Ohmic	16 A (AC1)	10 A (AC1)
Minimum switching current AC	100 mA	
Connection	Screw terminals	
Capacitive load	920 VA (115 µF)	580 VA (70 µF)
Number of 2-wire satellite units (ref. no. 1720 NE)	unlimited	unlimited
Number of 3-wire satellite units (ref. no. 1723 NE)	5	10
Number of push-buttons	unlimited	
Shut-off delay	without, 1 min, 5 min, 30 min, 60 min	
Switch-on delay	without	without, 3 min.
Function	<ul style="list-style-type: none"> <li>- Test operation for function test</li> <li>- Adaptive zero point circuit</li> </ul>	<p>In combination with automatic switch:</p> <ul style="list-style-type: none"> <li>- Output a2 switches depending on output a1 e.g. to switch on ventilation depending on the lighting and to switch it off with delay</li> <li>- Switch-on delay for output a2 can be set</li> <li>- Shut-off delay for output a2 can be set</li> </ul> <p>In combination with 3-wire satellite unit and 2-gang centre plate:</p> <ul style="list-style-type: none"> <li>- two independent outputs</li> </ul>



## ELECTRONIC SWITCH INSERT 1-CHANNEL | 1704 ESE

230 V ~ AC, 50/60 Hz

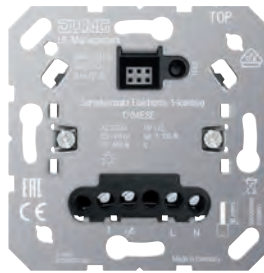

### CONNECTION AND FUNCTIONS

Attachments	.. 17180 .. / .. 17280 .. / .. 17181 .. / .. 17281 .. / .. DWPM17360 ..
Standby consumption	approx. 0.25 W
Switching current at 25 °C	
Ohmic	various; see product data sheet
Minimum switching current AC	
Connection	Screw terminals
Capacitive load	various; see product data sheet
Number of 2-wire satellite units (ref. no. 1720 NE)	unlimited
Number of 3-wire satellite units (ref. no. 1723 NE)	5
Number of push-buttons	unlimited
Shut-off delay	without
Switch-on delay	without
Function	<ul style="list-style-type: none"> <li>- Switching on uses a soft start that is gentle on the lamp</li> <li>- Electronic short-circuit protection</li> <li>- Electronic overtemperature protection</li> <li>- Test operation for function test</li> </ul> <p>Operation with neutral conductor:</p> <ul style="list-style-type: none"> <li>- Device supplies itself via phase conductor and neutral conductor; no leading edge or trailing edge phase control</li> </ul> <p>Operation without neutral conductor:</p> <ul style="list-style-type: none"> <li>- Supply via phase conductor and the connected load; leading and trailing edge phase control principle</li> <li>- Automatic or manual setting of the appropriate operating mode for the load</li> <li>- Display of the set operating mode using LED</li> </ul>



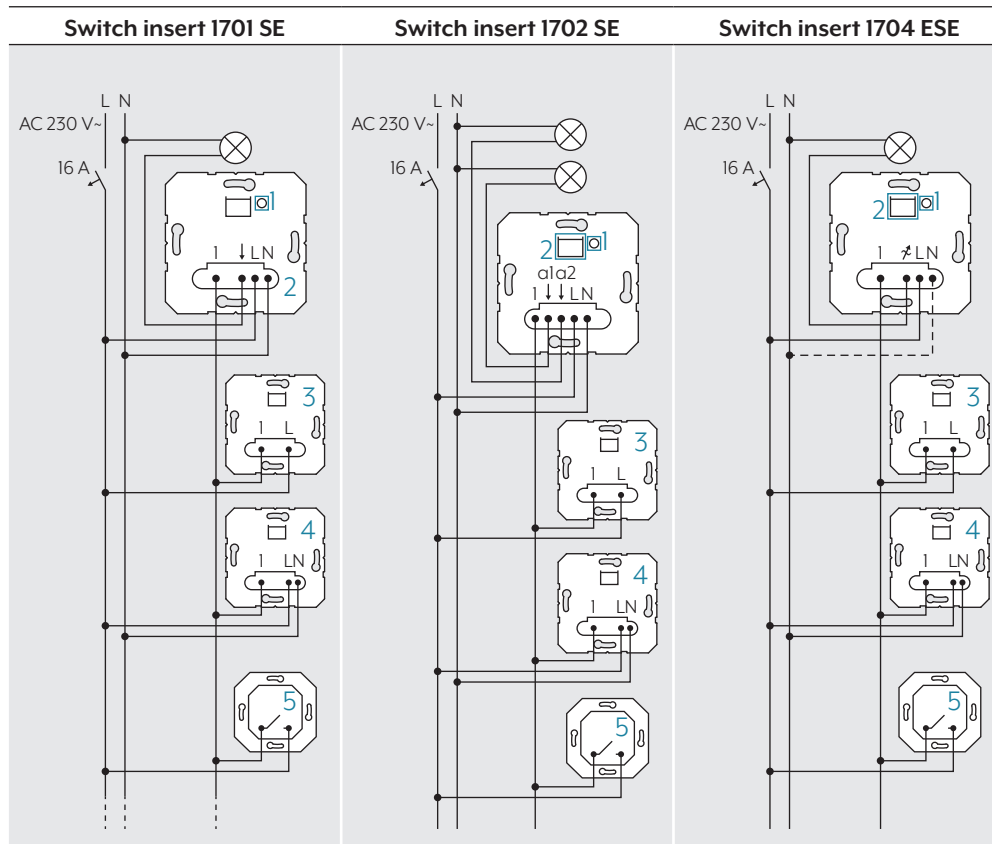



### 9.3.2 Installation and electrical connection



- (1) TEST button
- (2) Switch insert
- (3) 2-wire satellite unit
- (4) 3-wire satellite unit
- (5) Push-button, NO contact

- (1) TEST button
- (2) LED indicator and connection socket for attachment
- (3) 2-wire satellite unit
- (4) 3-wire satellite unit / rotary dimmer satellite unit
- (5) Push-button, NO contact

- (1) TEST button
- (2) LED indicator and connection socket for attachment
- (3) 2-wire satellite unit
- (4) 3-wire satellite unit
- (5) Push-button, NO contact

Usable wire cross sections		LED signalling	
	1 x 0.5 ... 4 mm <sup>2</sup>	LED colour	Specified shut-off delay
	2 x 0.5 ... 2,5 mm <sup>2</sup>	green	Switch without shut-off delay
	1 x 0.5 ... 4 mm <sup>2</sup>	ivory	Shut-off delay: 1 minute
	2 x 0.5 ... 2,5 mm <sup>2</sup>	blue	Shut-off delay: 5 minutes
	1 x 0.5 ... 4 mm <sup>2</sup>	yellow	Shut-off delay: 30 minutes
	2 x 0.5 ... 1,5 mm <sup>2</sup>	red	Shut-off delay: 60 minutes

1. Connect the switch insert according to the wiring diagram. Observe the usable wire cross-sections.
2. Optionally connect the 2-wire satellite unit (3), 3-wire satellite unit (4) and push-button, NO contact (5).
3. Mount the switch insert in the wall box. Note that the connection terminals are at the bottom.

**Do not attach or replace the attachment while it is energised, otherwise malfunctions can occur.**

4. Attach the frame and attachment.
5. Switch on the mains power.

**The load can be switched by briefly pressing the TEST button (I).**

6. Set the shut-off delay.
7. Press and hold the TEST button (I) for longer than 4 seconds.
8. Release the TEST button (I) briefly and then press the TEST button (I) so often until the LED lights in the colour of the desired shut-off delay (see table). This is saved automatically after 30 seconds or after pressing and holding the TEST button (I) for approx. 4 seconds. The save process was successful if the LED extinguishes.

### 9.3.3 Dimming inserts

#### STANDARD TOUCH DIMMER LED | 1710 DE

230 V ~ AC, 50/60 Hz

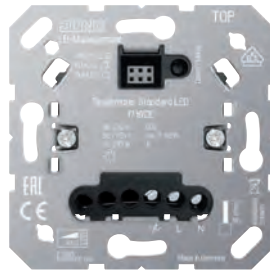

#### UNIVERSAL TOUCH DIMMER LED | 1711 DE

230 V ~ AC, 50/60 Hz

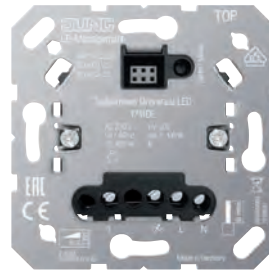

#### CONNECTION AND FUNCTIONS

Attachments	.. 17180 .. / .. 17280 .. / .. 17181 .. / .. 17281 .. / .. DWPM17360 ..	
Standby consumption	approx. 0.25 W	
Power dissipation	approx. 2 W	approx. 4 W
Ambient temperature	-5 ... +45 °C	
Connected load	various; see product data sheet	
Connection	Screw terminals	
Total length of load cable	100 m	
Number of 3-wire satellite units (ref. no. 1723 NE)	5	
Number of push-buttons	connection of satellite units is not possible	unlimited
Total length of satellite unit cable	100 m	
Function	<ul style="list-style-type: none"> <li>- The device uses the leading edge phase control or trailing edge phase control principle</li> <li>- Automatic or manual setting of the appropriate dimming principle for the load</li> <li>- Display of the set operating mode using LED</li> <li>- Device can be operated without neutral conductor</li> <li>- Switching on uses a soft start that is gentle on the lamp</li> <li>- Switching on with the last set brightness or saved switch-on brightness</li> <li>- Switch-on brightness can be permanently stored</li> <li>- Minimum brightness can be permanently stored</li> <li>- Electronic short-circuit protection with permanent switch-off after 7 seconds at the latest</li> <li>- Electronic overtemperature protection</li> <li>- Test operation for function test</li> <li>- Power extension possible using amplifiers</li> </ul>	

### 9.3.4 Installation and electrical connection

#### Touch dimmer 1710 DE

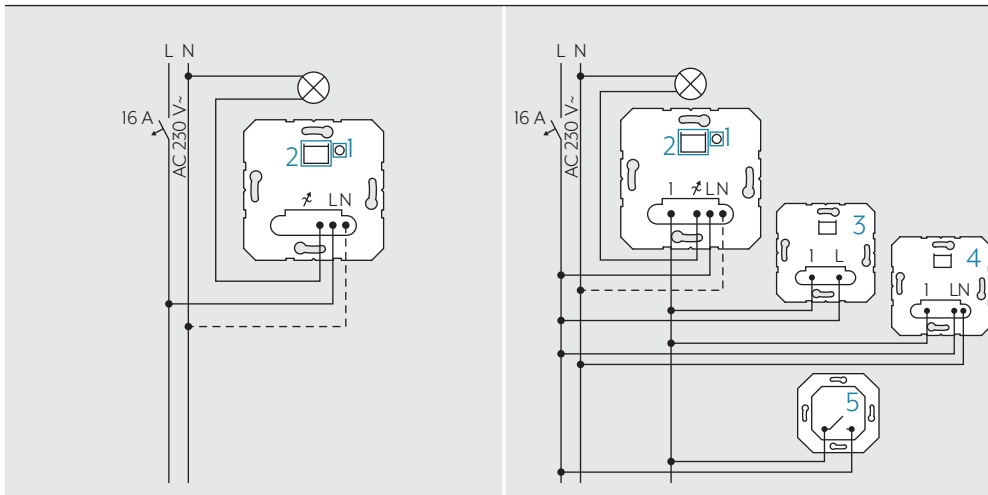

(1) Dimming mode button

(2) LED indicator and connection socket for attachment

(1) Dimming mode button

(2) LED indicator and connection socket for attachment





(3) 2-wire satellite unit

(4) 3-wire satellite unit / rotary dimmer satellite unit

(5) Push-button, NO contact

Connect maximum 600 W LED or compact fluorescent lamps per 16 A circuit breaker. The connected load and dimming quality of LED lamps depend on the type of lamp and the installation conditions. The maximum brightness can be reduced depending on the type of lamp. Operation with a neutral conductor reduces this effect and the possibility of unsuitable combinations of dimmers and LED lamps.

#### Usable wire cross sections

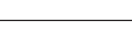
	1 x 0.5 ... 4 mm <sup>2</sup>
	2 x 0.5 ... 2,5 mm <sup>2</sup>
	1 x 0.5 ... 4 mm <sup>2</sup>
	2 x 0.5 ... 2,5 mm <sup>2</sup>
	1 x 0.5 ... 4 mm <sup>2</sup>
	2 x 0.5 ... 1,5 mm <sup>2</sup>

#### LED signalling

LED colour	Dimming mode
GN (green)	R, L, C, LED
RD (red)	LED trailing edge phase control
BU (blue)	LED leading edge phase control

Requirements: Load is switched off.

1. Press and hold the dimming mode button (1) until the LED (2) lights.
2. Briefly press the dimming mode button (1) repeatedly until the required operating mode is selected. LED (2) lights in the colour of the selected operating mode.
3. Press and hold the dimming mode button (1) for longer than 1 second. LED (2) flashes. Light switches to the lowest brightness and becomes brighter slowly.

**When changing the operating mode to Universal, the calibration to the load is performed first. Continue to keep the dimming mode button (1) pressed.**

**Lighting of the lamp must be recognisable in the lowest dim position.**

4. Release the dimming mode button (1) as soon as the required minimum brightness is reached. LED (2) lights, operating mode and minimum brightness are set.
5. Optionally change minimum brightness again: Press and hold the dimming mode button (1) for longer than 1 second. Light switches to the lowest brightness again and becomes brighter slowly.
6. Save settings: Press the dimming mode button (1) for shorter than 1 second or do not actuate the button for 30 seconds. LED (2) extinguishes.

### 9.3.5 Expansion inserts

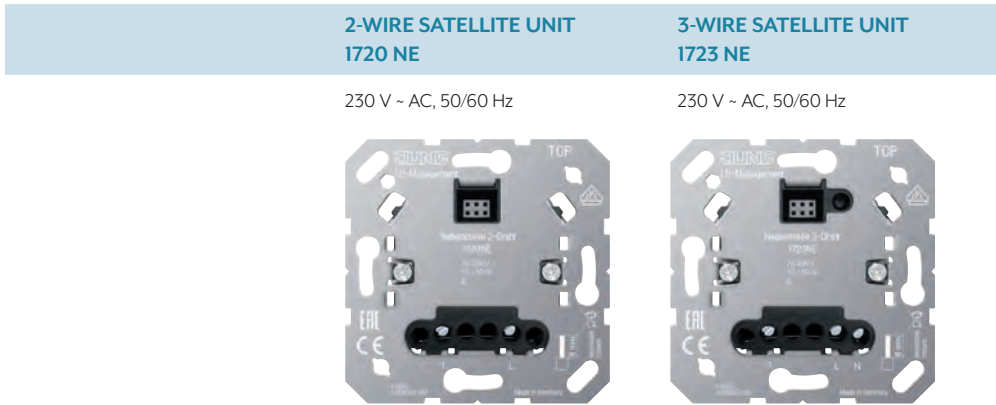

#### CONNECTION AND FUNCTIONS

Attachments	.. 1700 ..	.. 17180 .. / .. 17280 .. / .. 17181 .. / .. 17281 .. / .. DWPM 17360 ..
Ambient temperature	-20 ... +45 °C	
Power consumption	-	-
DALI rated voltage	-	-
Output current	-	-
Short-circuit current	-	-
Colour temperature setting	-	-
Number of DALI devices	-	-
Number of parallel control units	-	-
Pulse duration	-	-
Pulse interval	-	-
Connection	Screw terminals	
Function	- Satellite unit operation with centre plate	- Extension of the detection field of motion and presence detectors - central control of multiple main units

**POWER DALI PUSH-BUTTON  
CONTROLLER TW | 1713 DSTE**

230 V ~ AC, 50/60 Hz

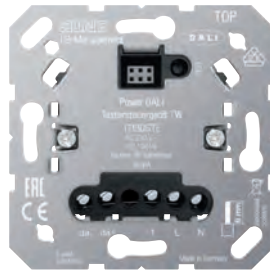

**PULSE INSERT  
1708 IE**

230 V ~ AC, 50 Hz

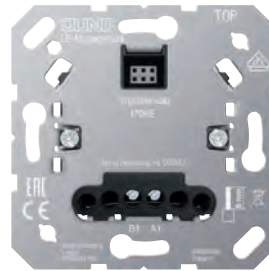

**CONNECTION AND FUNCTIONS**

Attachments	.. 17180 .. / .. 17280 .. / .. 17181 .. / .. 17281 .. / .. DWPM17360 ..	
Ambient temperature	-5 ... +45 °C	
Power consumption	max. 2.8 W	0.25 ... 0.45 W
DALI rated voltage	16 V DC	
Output current	max. 36 mA	-
Short-circuit current	max. 60 mA	-
Colour temperature setting	2000 ... 10000 K	-
Number of DALI devices	18	-
Number of parallel control units	4	-
Pulse duration	-	approx. 60 ms
Pulse interval	-	approx. 8 s
Connection	-	Screw terminals
Function	<ul style="list-style-type: none"> <li>- DALI supply for maximum 18 nodes</li> <li>- Parallel switching of up to 4 DALI control units with the possibility to supply up to 72 nodes</li> <li>- Saving the minimum brightness, the coldest and the warmest colour temperature</li> <li>- Switching on with the last set brightness / colour temperature or with the saved switch-on brightness / colour temperature</li> <li>- Test operation for function test</li> </ul>	<ul style="list-style-type: none"> <li>- only use in combination with the staircase automatic switch ref. no. 1208REG</li> <li>- automatic switching</li> <li>- Operation in 3-wire or 4-wire circuit</li> <li>- Insert implemented in 2-wire technology</li> </ul>

### 9.3.6 Installation and electrical connection

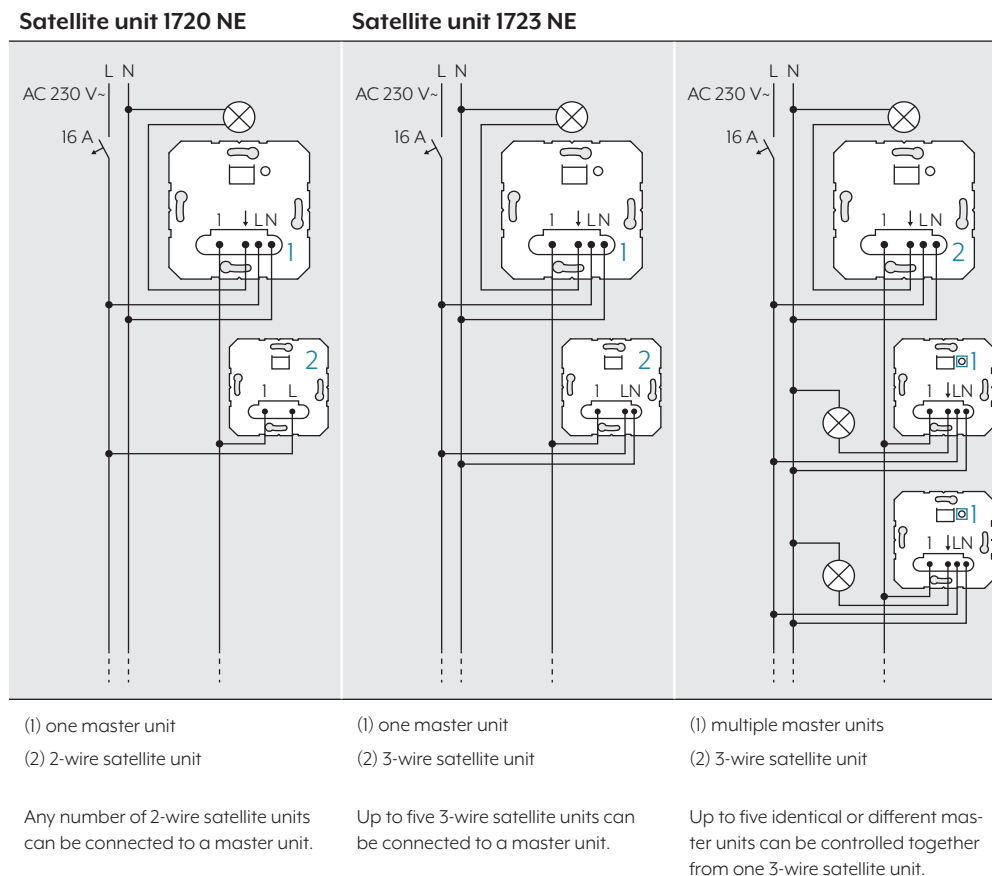

#### Usable wire cross sections

	1 x 0.5 ... 4 mm <sup>2</sup>
	2 x 0.5 ... 2,5 mm <sup>2</sup>
	1 x 0.5 ... 4 mm <sup>2</sup>
	2 x 0.5 ... 2,5 mm <sup>2</sup>
	1 x 0.5 ... 4 mm <sup>2</sup>
	2 x 0.5 ... 1,5 mm <sup>2</sup>

The function of the satellite unit depends on the insert and attachment of the master unit.

1. Connect the satellite unit according to the wiring diagram. Observe the usable wire cross-sections.
2. Mount the insert in the wall box. Note that the connection terminals are at the bottom.

**Do not attach or replace the attachment while it is energised, otherwise malfunctions can occur.**

3. Put the frame on the attachment.
4. Switch on the mains power.



**Power DALI push-button controller TW 1713 DSTE**

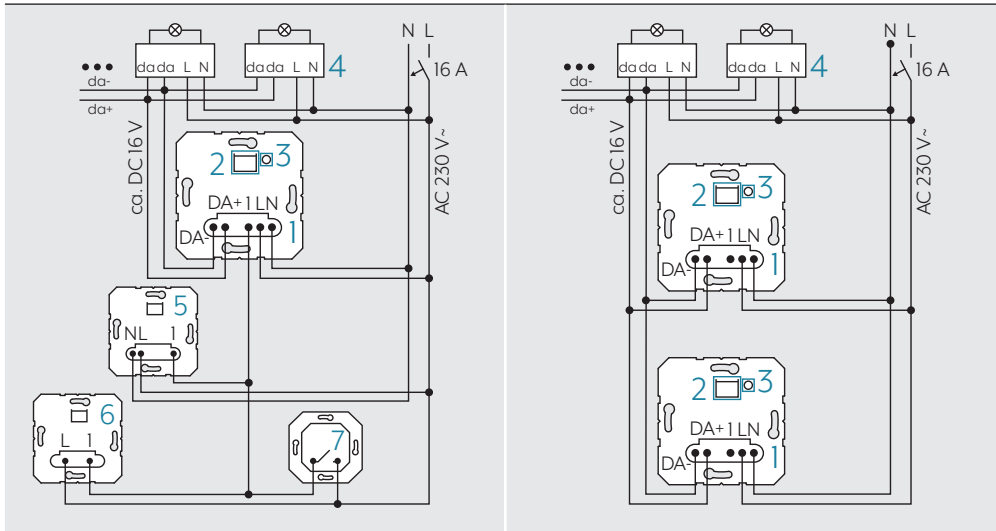

- (1) DALI insert
- (2) Attachment interface with LED
- (3) TEST button
- (4) DALI device
- (5) 3-wire satellite unit
- (6) 2-wire satellite unit
- (7) Push-button, NO contact

A 3-wire satellite unit can only control one DALI insert. Central control is not possible.

- (1) DALI inserts
- (2) Attachment interface with LED
- (3) TEST button
- (4) DALI device

Ensure correct polarity when connecting several DALI inserts in parallel.

**Usable wire cross sections**

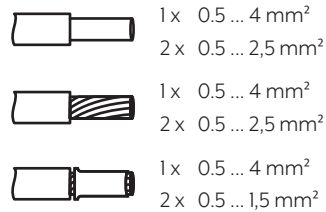

1. Connect the DALI insert (1) and DALI device (4) according to the wiring diagram. Observe the manufacturer's specifications and the usable wire cross sections.
  2. If several circuit breakers supply dangerous voltages to the device or load, couple the circuit breakers or label the circuit breakers with a warning sign that disconnection is ensured.
- The connected DALI devices may be operated on different phases.**
3. Briefly press the TEST button to switch the connected lighting even without the attachment.

**Depending on the attachment, the DALI insert can switch light, set and save brightness and colour temperature.**

### Pulse insert with staircase automatic switch I208 REG

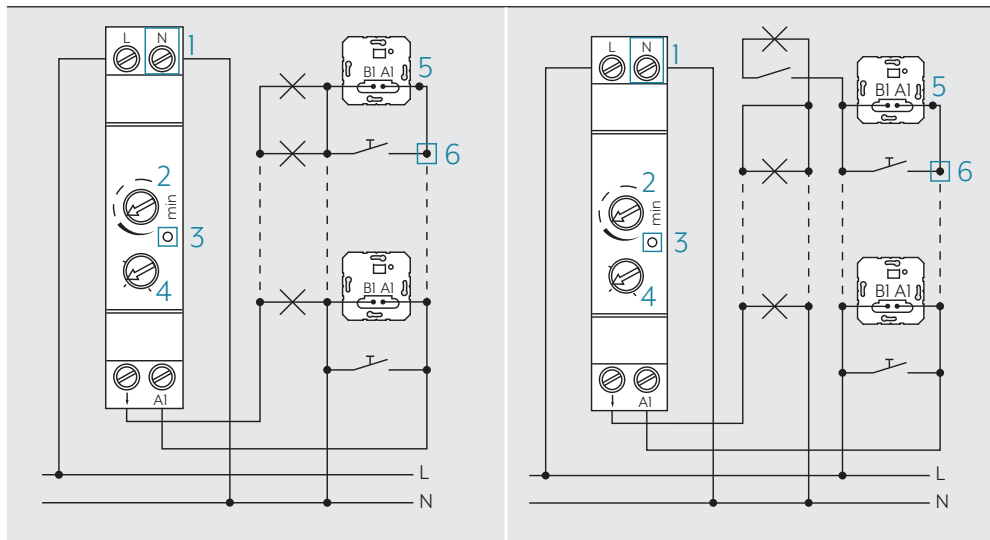

- (1) Automatic switch for rail mounting  
 (2) Shut-off delay potentiometer  
 (3) LED

- (4) Operating mode adjuster  
 (5) Pulse insert with motion detector or button attachment  
 (6) Push-button, NO contact

### Usable wire cross sections

#### Automatic switch for rail mounting

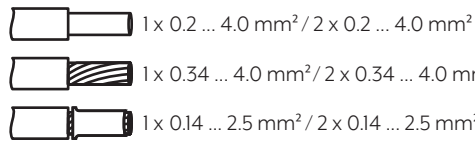

#### Pulse insert

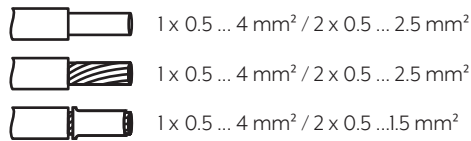

**Do not operate multiple automatic switches for rail mounting next to each other. Avoid sources of heat in the immediate vicinity. Ensure sufficient heat dissipation.**

- Observe the usable wire cross sections of the automatic switch for rail mounting and pulse insert.
- Mount the automatic switch for rail mounting (1) on the DIN rail.
- Connect the automatic switch for rail mounting (1), pulse insert (5) and push-button (6) according to the wiring diagram.
- Mount the pulse insert or push-button in the wall box. Note that the connection terminals of the pulse insert are at the bottom.
- Mount frame and attachment.
- If several circuit breakers supply dangerous voltages to the device or load, couple the circuit breakers or label the circuit breakers with a warning sign that disconnection is ensured.
- Set shut-off delay and operating mode on the automatic switch for rail mounting:
  - CLOCK: automatic function without switch-off prewarning
  - CLOCK LIGHT: automatic function with switch-off prewarning
  - RADIATE LIGHT: light is switched on continuously
  - LIGHT: light is switched off continuously

**In the case of automatic function with switch-off prewarning, the service life of the relay contact may be reduced when fluorescent lamps or energy-saving lamps are used. The specified shut-off delay is increased by approx. 30 seconds.**

- Set the brightness threshold and sensitivity on the motion detector attachment, see the instructions for the respective attachment

**Not all functions on the motion detector can be used in combination with a pulse insert.**

## 9.4 Attachments

### 9.4.1 Standard automatic switch 1.1 m

The IP 44 protection level is ensured with the sealing gasket, ref. no. 551 WU, and range-specific IP 44 frames.

#### A RANGE



MATERIAL	COLOUR	REF. NO.
Thermoplastic (breakproof) high-gloss	ivory	A 17180 (WU)
	white	A 17180 (WU) WW
	black	A 17180 (WU) SW

MATERIAL	COLOUR	REF. NO.
Thermoplastic (breakproof) lacquered	aluminium	A 17180 (WU)AL
	champagne	A 17180 (WU) CH
	mocha	A 17180 (WU) MO
	matt anthracite	A 17180 (WU) ANM

The products are also available with integrated sealing gasket (identified by WU in the reference number).

#### CD RANGE



MATERIAL	COLOUR	REF. NO.
Thermoplastic (breakproof) high-gloss	ivory	CD 17180 (WU)
	white	CD 17180 (WU) WW
	brown	CD 17180 (WU) BR
	grey	CD 17180 (WU) GR
	light grey	CD 17180 (WU) LG
	black	CD 17180 (WU) SW

MATERIAL	COLOUR	REF. NO.
Lacquered metal versions	gold bronze	CD 17180 (WU) GB
	platinum	CD 17180 (WU) PT

The products are also available with integrated sealing gasket (identified by WU in the reference number).

#### LS RANGE



MATERIAL	COLOUR	REF. NO.
Thermoplastic (breakproof) high-gloss	ivory	LS 17180 (WU)
	white	LS 17180 (WU) WW
	light grey	LS 17180 (WU) LG
	black	LS 17180 (WU) SW

MATERIAL	COLOUR	REF. NO.
Lacquered metal versions	aluminium	AL 17180 (WU)
	stainless steel	ES 17180 (WU)
	anthracite	AL 17180 (WU) AN
	dark	AL 17180 (WU) D
	classic brass	ME 17180 (WU) C
	antique brass	ME 17180 (WU) AT

The products are also available with integrated sealing gasket (identified by WU in the reference number).

## 9.4.2 Standard automatic switch 2.2 m

The IP 44 protection level is ensured with the sealing kit AS A/CD 50 DS and range-specific IP 44 frames.

### A / AS RANGE



MATERIAL	COLOUR	REF. NO.
Thermoplastic (breakproof) high-gloss	ivory	THE A 17280
	white	A 17280 WW
	black	A 17280 SW

MATERIAL	COLOUR	REF. NO.
Thermoplastic (breakproof) lacquered	aluminium	A 17280 AL
	champagne	A 17280 CH
	mocha	A 17280 MO
	matt anthracite	A 17280 ANM

### CD RANGE



MATERIAL	COLOUR	REF. NO.
Thermoplastic (breakproof) high-gloss	ivory	CD 17280
	white	CD 17280 WW
	grey	CD 17280 GR
	light grey	CD 17280 LG
	black	CD 17280 SW

MATERIAL	COLOUR	REF. NO.
Lacquered metal versions	gold bronze	CD 17280 GB
	platinum	CD 17280 PT

### LS RANGE



MATERIAL	COLOUR	REF. NO.
Thermoplastic (breakproof) high-gloss	ivory	LS 17280
	white	LS 17280 WW
	light grey	LS 17280 LG
	black	LS 17280 SW



MATERIAL	COLOUR	REF. NO.
Lacquered metal versions	aluminium	AL 17280
	stainless steel	ES 17280
	anthracite	AL 17280 AN
	dark	AL 17280 D
	classic brass	ME 17280 C
	antique brass	ME 17280 AT

### 9.4.3 Installation and electrical connection of the Standard automatic switches 1.1 m and 2.2 m

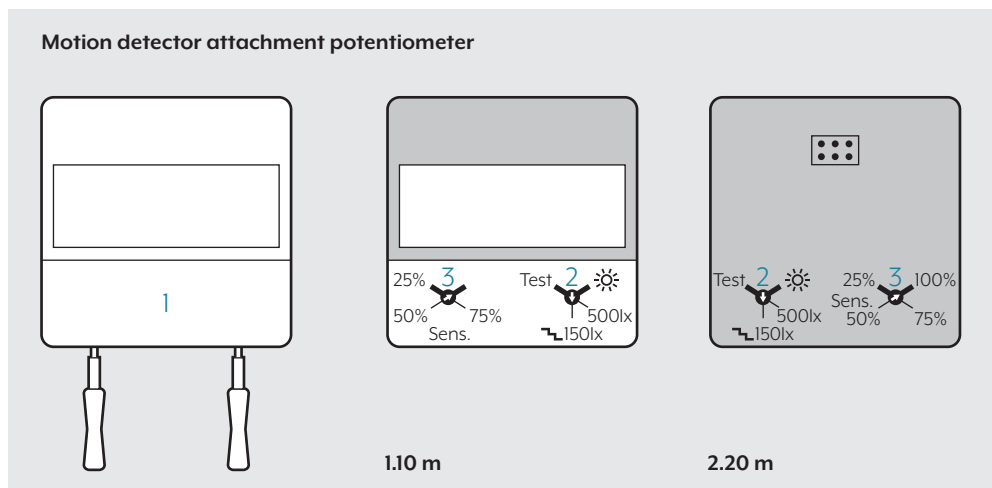
1. Make sure that the mounting location is free of vibrations.
2. For optimum range, select the mounting location tangential to the direction of movement (a detailed description of the range can be found in the operating instructions Standard Automatic Switch ref. no ... 17180 ... and ... 17280 ..).
3. Avoid sources of interference in the detection range.
4. Connect the flush-mounted insert correctly.
5. Further installation steps are necessary to ensure IP44 protection (see instructions for sealing kit).
6. Put the attachment with frame on the flush-mounted insert.
7. You can reduce the detection field by using a shutter. You can increase the detection range by using satellite units (see operating manual for Standard automatic switch ref. no. ...). 17180 ... and ... 17280 ..).
8. Set the brightness threshold and the sensitivity.
9. The potentiometers for the 1.10 m motion detector attachment are located behind the cover. The potentiometers for the 2.20 m motion detector attachment are located on the back of the device. The shut-off delay cannot be changed.



10. Carefully remove the cover (1) using a screwdriver.
11. Set the brightness threshold on the attachments of the main unit and on all satellite units.
12. Turn potentiometer (2) to one of the four defined values:

TEST	Test detection range
	Day operation: The motion detector functions regardless of brightness.
500 lux	individual setting
 150 lux	Setting for staircases according to DIN EN12464-1.

13. Set the required sensitivity on the potentiometer (3).
14. Test the detection range by turning the potentiometer (2) to TEST.

### 9.4.4 Universal automatic switch 1.1 m

The IP 44 protection level is ensured with the sealing gasket 551 WU, and range-specific IP 44 frames.

#### A / AS RANGE



MATERIAL	COLOUR	REF. NO.
Thermoplastic (breakproof) high-gloss	ivory	A 17181 WU
	white	A 17181 (WU) WW
	black	A 17181 (WU)SW

MATERIAL	COLOUR	REF. NO.
Thermoplastic (breakproof) lacquered	aluminium	A 17181 (WU) AL
	champagne	A 17181 (WU) CH
	mocha	A 17181 (WU) MO
	matt anthracite	A 17181 (WU) ANM

The products are also available with integrated sealing gasket (identified by WU in the reference number).

#### CD RANGE



MATERIAL	COLOUR	REF. NO.
Thermoplastic (breakproof) high-gloss	ivory	CD 17181 (WU)
	white	CD 17181 (WU) WW
	brown	CD 17181 (WU) BR
	grey	CD 17181 (WU) GR
	light grey	CD 17181 (WU) LG
	black	CD 17181 (WU) SW

MATERIAL	COLOUR	REF. NO.
Lacquered metal versions	gold bronze	CD 17181 (WU) GB
	platinum	CD 17181 (WU) PT

The products are also available with integrated sealing gasket (identified by WU in the reference number).

#### LS RANGE



MATERIAL	COLOUR	REF. NO.
Thermoplastic (breakproof) high-gloss	ivory	LS 17181 (WU)
	white	LS 17181 (WU) WW
	light grey	LS 17181 (WU) LG
	black	LS 17181 (WU) SW

MATERIAL	COLOUR	REF. NO.
Lacquered metal versions	aluminium	AL 17181 (WU)
	stainless steel	ES 17181 (WU)
	anthracite	AL 17181 (WU) AN
	dark	AL 17181 (WU) D
	classic brass	ME 17181 (WU) C
	antique brass	ME 17181 (WU) AT

The products are also available with integrated sealing gasket (identified by WU in the reference number).

## 9.4.5 Universal automatic switch 2.2 m

The IP 44 protection level is ensured with the sealing kit AS A/CD/LS 50 DS and range-specific IP 44 frames.

### A / AS RANGE



MATERIAL	COLOUR	REF. NO.
Thermoplastic (breakproof) high-gloss	ivory	THE A 17281
	white	A 17281 WW
	black	A 17281 SW

MATERIAL	COLOUR	REF. NO.
Thermoplastic (breakproof) lacquered	aluminium	A 17281 AL
	champagne	A 17281 CH
	mocha	A 17281 MO
	matt anthracite	A 17281 ANM

### CD RANGE



MATERIAL	COLOUR	REF. NO.
Thermoplastic (breakproof) high-gloss	ivory	CD 17281
	white	CD 17281 WW
	grey	CD 17281 GR
	light grey	CD 17281 LG
	black	CD 17281 SW

MATERIAL	COLOUR	REF. NO.
Lacquered metal versions	gold bronze	CD 17281 GB
	platinum	CD 17281 PT

### LS RANGE



MATERIAL	COLOUR	REF. NO.
Thermoplastic (breakproof) high-gloss	ivory	LS 17281
	white	LS 17281 WW
	light grey	LS 17281 LG
	black	LS 17281 SW

MATERIAL	COLOUR	REF. NO.
Lacquered metal versions	aluminium	AL 17281
	stainless steel	ES 17281
	anthracite	AL 17281 AN
	dark	AL 17281 D
	classic brass	ME 17281 C
	antique brass	ME 17281 AT

#### 9.4.6 Installation and electrical connection of the Universal automatic switches 1.1 m and 2.2 m

1. Make sure that the mounting location is free of vibrations.
2. For optimum range, select the mounting location tangential to the direction of movement (a detailed description of the range can be found in the operating instructions Standard Automatic Switch ref. no ... 17181 ... and ... 17281 ..).
3. Avoid sources of interference in the detection range.
4. Connect the flush-mounted insert correctly.
5. Further installation steps are necessary to ensure IP44 protection (see instructions for sealing kit).
6. Put the attachment with frame on the flush-mounted insert.
7. You can reduce the detection field by using a shutter. You can increase the detection range by using satellite units (see operating manual for Universal automatic switch ref. no. ... 17181 ... and ... 17281 ..).
8. Pair the Universal automatic switch via Bluetooth to a smart phone.

##### MOTION DETECTOR ATTACHMENT 1.10 M

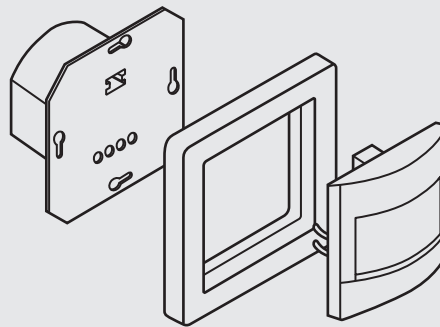

##### MOTION DETECTOR ATTACHMENT 2.20 M

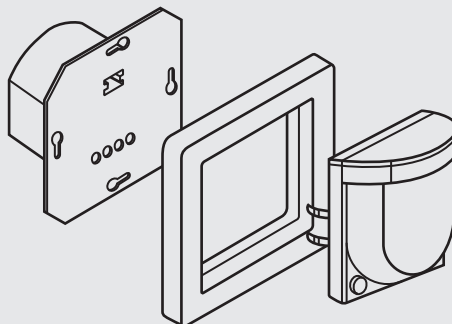

9. Activate the pairing mode on the device.
  - Universal automatic switch 1.1 m: Switch the automatic switch to Continuous On and darken the sensors for at least four seconds.
  - Universal automatic switch 2.2 m: Press and hold the Bluetooth button for at least four seconds.
10. Search for available devices using the app and follow the instructions on the display. Each Bluetooth device can manage up to eight smart phones.



- ii. Make the fine adjustments via the JUNG Clever Config app. The settings can be checked on the device using the status LEDs.

<b>red LED lights</b>	Self-test
<b>red LED flashes 3 s on / 3 s off</b>	Alarm function active
<b>red LED flashes 0.5 s on / 0.5 s off</b>	Alarm has been triggered
<b>red LED flashes three times, then 1 s pause</b>	Attachment was previously connected to another insert
<b>yellow LED lights</b>	"Continuous Off" or "Off for 0.5 -5 hours" active
<b>yellow LED flashes</b>	Presence simulation active
<b>green LED lights</b>	"Continuous On" or "On for 0.5 -5 hours" active
<b>blue LED lights</b>	Device is paired with a mobile device and active app
<b>blue LED flashes 0.5 s on / 0.5 s off</b>	Bluetooth pairing mode active

### 9.4.7 Mini Basic ceiling observer / presence detector / motion detector

There are extensive areas in a hotel that can be illuminated in an energy-efficient manner with automatically switched light. The JUNG ceiling observer / presence detector and the JUNG motion detector Mini Basic are suitable for all areas where the installation of an automatic switch on the wall is not possible or not desired. The DWPM 17360 .. ceiling observer / presence detector is mounted on fixed ceilings in mounting boxes according to DIN 49073 or, with the additionally available surface-mounted housing, installed in historical existing buildings in a way that is as gentle on the structure as possible. Another surface-mounted variant is the ceiling observer/presence detector DWPM K 360 .. with integrated power section.

A matching protective cage is available for particular protection, for example in the fitness area or the parking garage.

The JUNG motion detector Mini Basic BM 360MB WW is mainly used in hotel rooms. The motion detector is mounted on a room ceiling and monitors the area below.

#### Ceiling observer / presence detector for use with various inserts

##### STANDARD



MATERIAL	COLOUR	REF. NO.
Plastic	white	DWPM 17360 WW
	aluminium (lacquered)	DWPM 17360 AL

#### Ceiling observer / presence detector with integrated power section

##### STANDARD



MATERIAL	COLOUR	REF. NO.
Plastic	white	DWPM K 360 WW
	aluminium (lacquered)	DWPM K 360 AL

#### Motion detector Mini Basic

##### STANDARD



MATERIAL	COLOUR	REF. NO.
Plastic	white	BM 360MB WW

### 9.4.8 Installation and electrical connection of ceiling observer / presence detector

1. Make sure that the mounting location is free of vibrations.
2. For optimum range, make sure that the installation location is free of interference (a detailed description of the range can be found in the operating manuals for the ceiling observers / presence detectors DWPM 17360 .. and DWPM K 360 ..).

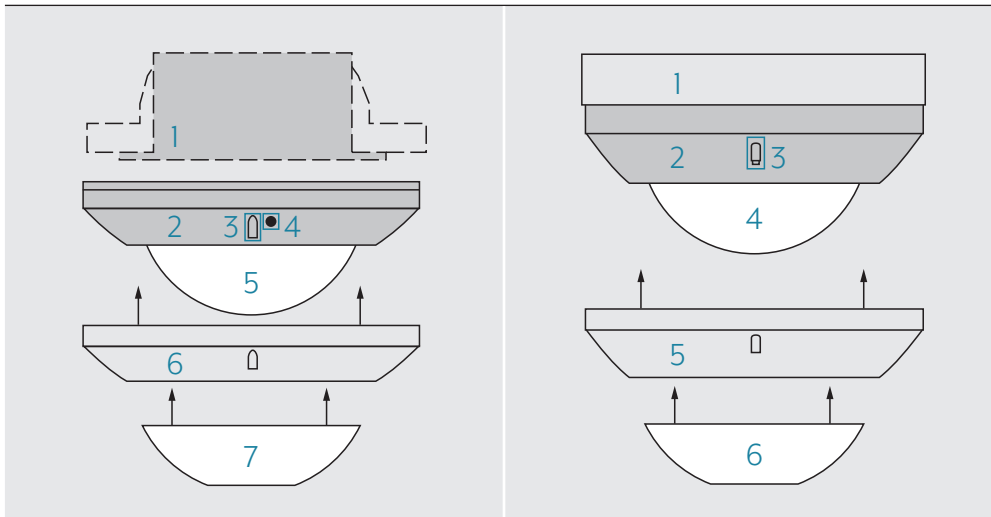

- (1) Flush-mounted insert
- (2) Sensor attachment
- (3) Brightness sensor
- (4) Bluetooth push-button
- (5) Sensor window and status LEDs I
- (6) Decorative ring
- (7) Snap-on cover

- (1) Junction box
- (2) Sensor attachment
- (3) Brightness sensor
- (4) Sensor window with red and blue LED indicator
- (5) Decorative ring
- (6) Snap-on cover

3. Connect the flush-mounted insert correctly. This is not necessary for the DWPM K 360 .. because it has an integrated power section and is surface mounted.
4. You can reduce the detection field by using a shutter. You can increase the detection range by using satellite units (see operating manuals for ceiling observer / presence detector DWPM 17360 .. and DWPM K 360 ..).
5. Adjust the ceiling observer / presence detector individually. Detailed instructions can be found in the respective operating manuals DWPM 17360 .. and DWPMK 360 .. .

**Example installation of a ceiling observer / presence detector with satellite units**  
**Hotel corridor**

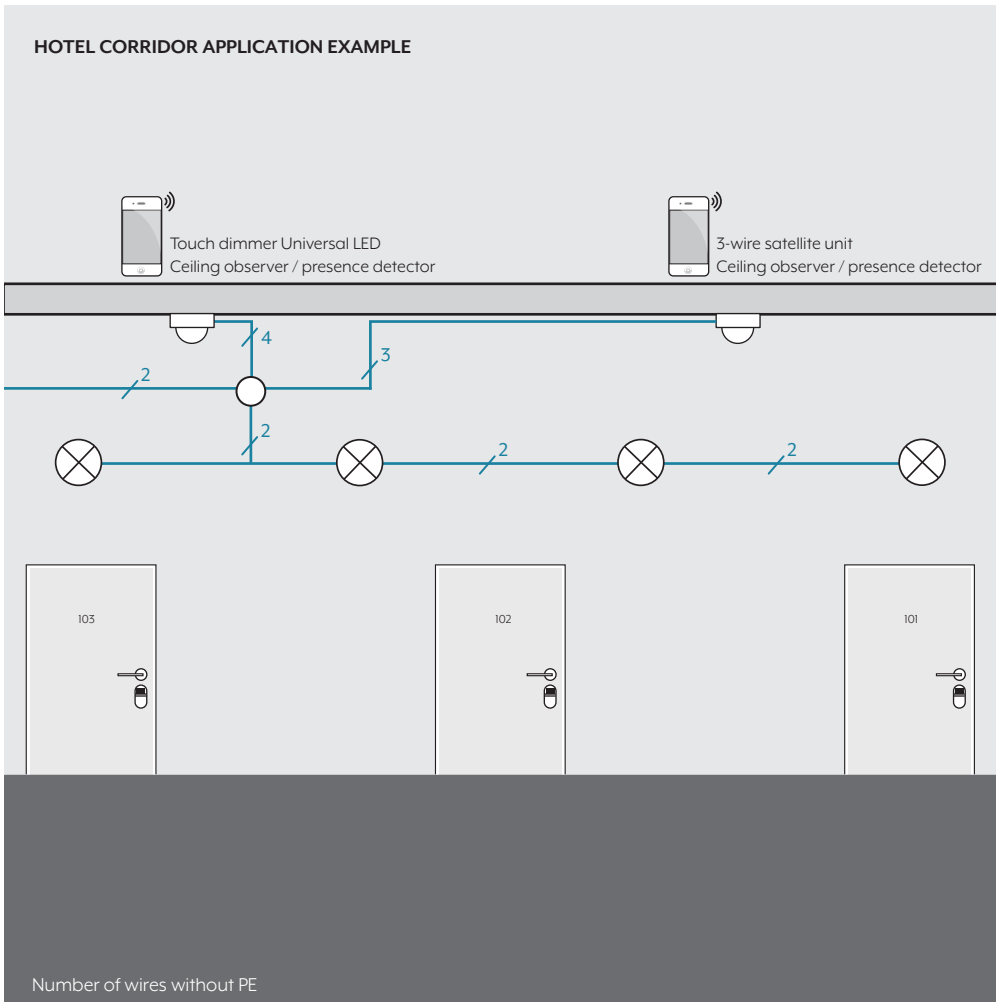

### Installation and electrical connection of motion detector Mini Basic

1. Make sure that the mounting location is free of vibrations.
2. Avoid sources of interference, such as heating, ventilation or air conditioning systems in the detection range. Sources of interference and cooling lamps can result in unwanted detections.

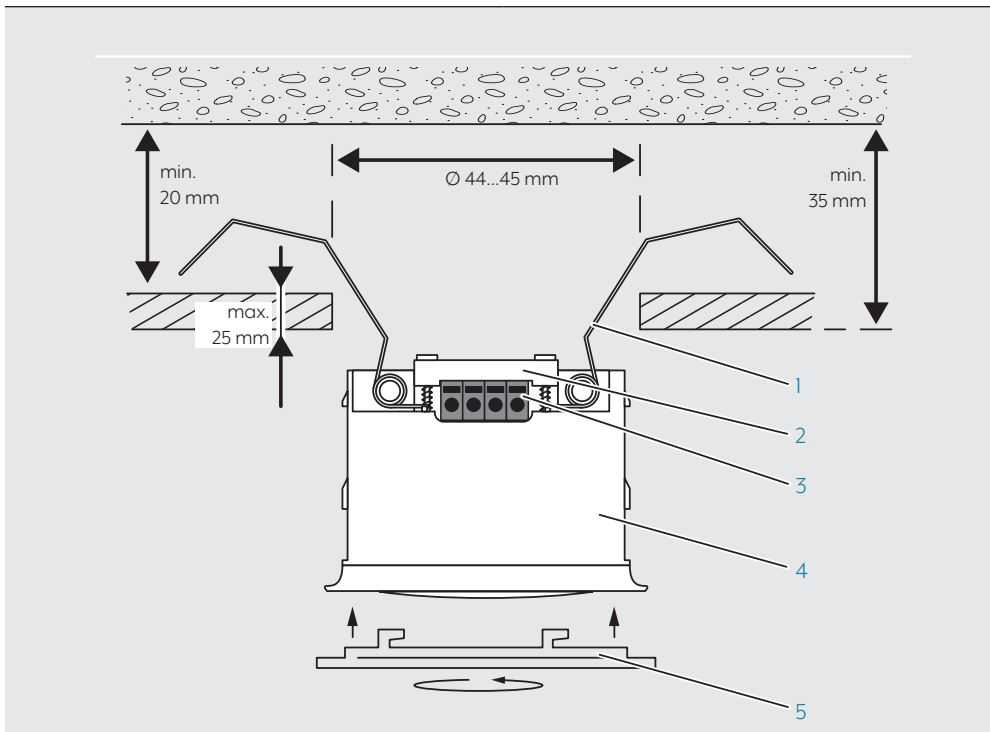

- |                    |                     |
|--------------------|---------------------|
| (1) Spring clamp   | (4) Motion detector |
| (2) Cable fastener | (5) Design ring     |
| (3) Terminal       |                     |

#### Usable wire cross sections

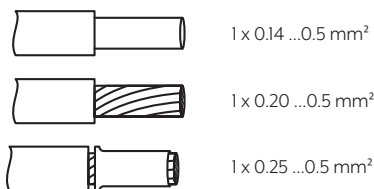

3. Make a ceiling cut-out with a diameter of 44...45 mm.  
Note that the environment in the false ceiling must be dry. The thickness of the false ceiling must not exceed 25 mm. The installation depth of the motion detector must be at least 35 mm. The distance between the concrete ceiling and the false ceiling must be at least 20 mm.
4. Use the unchoked output of a KNX power supply or the power supply unit with safety extra-low voltage as the power supply.
5. Connect the connection cable to the terminal.
6. Secure the connection cable using the provided cable fastener.
7. Bend the spring clamp back and push the motion detector into the false ceiling.
8. Attach the design ring and turn the ring clockwise.

### Connection of motion detector Mini Basic and compatible devices

#### CONNECTION TO MULTISTATION

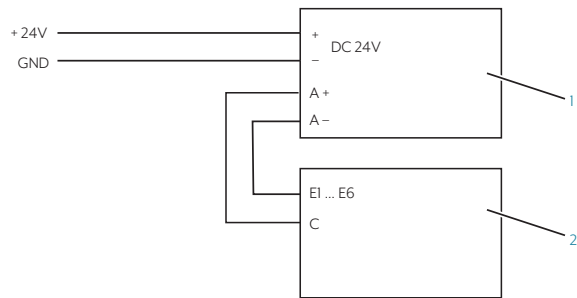

- (1) Motion detector Mini Basic
- (2) Multistation

#### CONNECTION TO 6-GANG BINARY INPUT

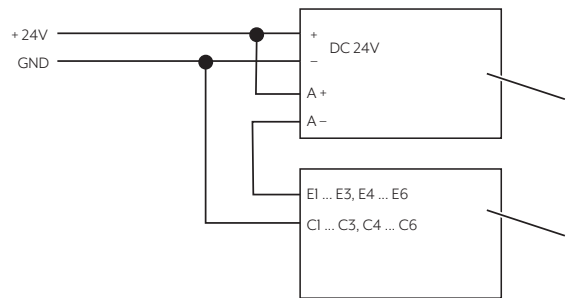

- (1) Motion detector Mini Basic
- (3) 6-gang binary input

#### CONNECTION TO PUSH-BUTTON INTERFACE, 2-GANG, PUSH-BUTTON INTERFACE, 4-GANG

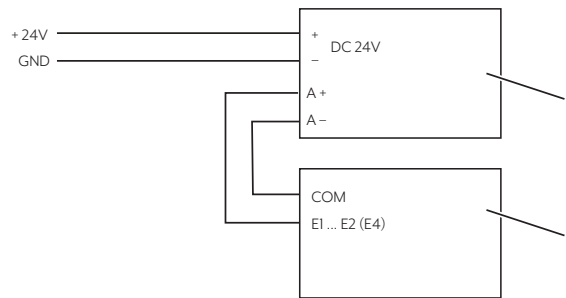

- (1) Motion detector Mini Basic
- (4) Push-button interface, 2-gang / push-button interface, 4-gang

**CONNECTION TO SWITCH ACTUATOR, 2-GANG**

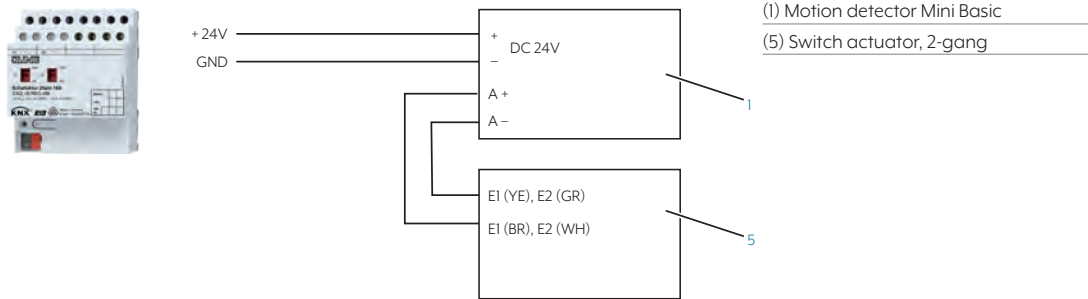

**CONNECTION TO 8-GANG BINARY INPUT**

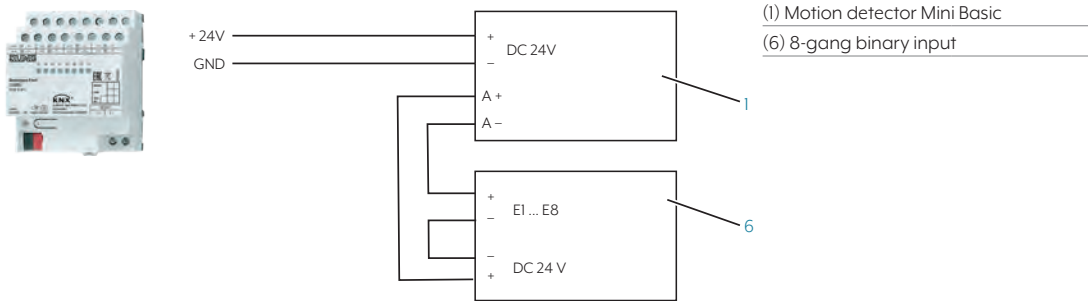

**CONNECTION TO FLUSH-MOUNTED BLINDS ACTUATOR, 1-GANG WITH SATELLITE UNIT ACTUATOR**

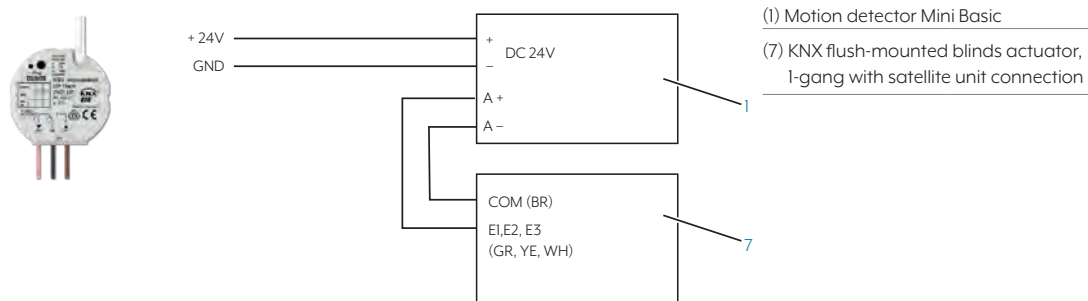

## 9.5 Setting up detection fields

If a motion detector is supplied with mains voltage, it first switches on the light.

A calibration process of the environment then starts for a maximum of 60 seconds. In this time, no movement is detected and no switching command is accepted.

### Standard and Universal automatic switches

The detection fields of the different automatic switches depend on the nominal mounting height. In the case of nominal mounting height of the motion detectors of 1.10 metres or 2.20 metres, the following results as seen from the mounting position:

- A detection field with a detection angle of 180°
- A frontal monitoring range of up to 30 metres
- A lateral monitoring range of up to 15 metres

For more detailed information, see the operating manuals of the various automatic switches.

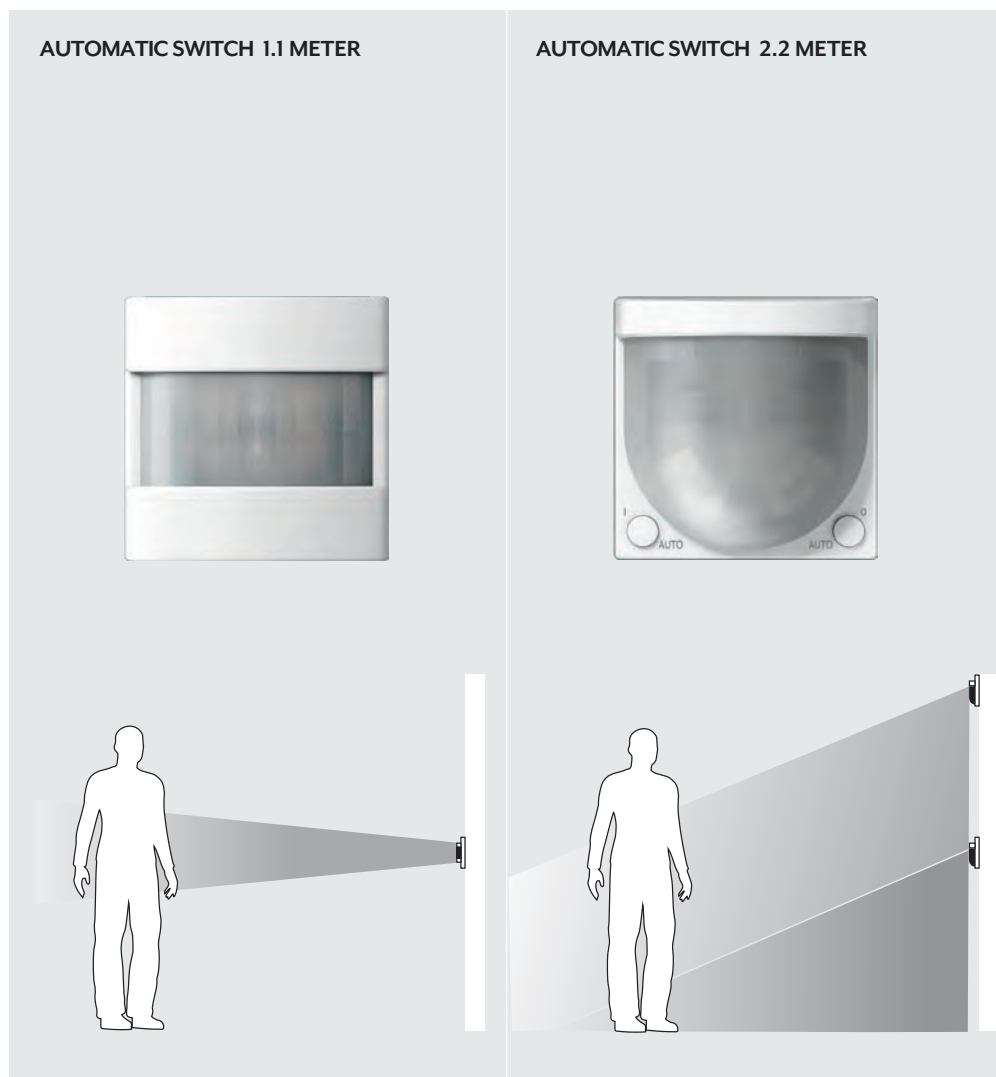



### Options for limitation of the detection field

The detection field of the automatic switches can be restricted if required.

A shutter that limits the detection field to an angle of  $90^\circ$  is included in the scope of delivery of the Standard and Universal 1.1 m automatic switches. The shutter can optionally be installed on the right or on the left. The individual sensors of the 1.1 m Universal automatic switch can also be activated / deactivated using the Clever Config app. Thus, the detection range on the left and on the right can be restricted by  $60^\circ$ . The detection field of the 2.2 m Universal automatic switch can also be customised via the Clever Config app.

### Ceiling observer / presence detector

The monitoring diameter of the ceiling observer / presence detector depends on the mounting height. With a nominal mounting height of 3 metres, a ceiling observer / presence detector has a monitoring area of 20 metres in diameter. You can set the detection field via Clever Config App or IR remote control (see operating manual DWPMK 360 ..).



### Detection field of the motion detector Mini Basic

The motion detector Mini Basic has a detection field of 360°. The diameter of the detection field depends on the mounting height and the direction of movement of persons in the detection field. As the mounting height increases, the detection field increases, and at the same time the detection density and sensitivity are reduced. The following applies for a mounting height of 3 m:

- Range for tangential movement on the floor: approx. 3 m.
  - The tangential movement is interpreted more clearly by the PIR sensor, as more segments are passed through than with a radial movement of the body.
- Range for radial movement on the floor: approx. 2.5 m.

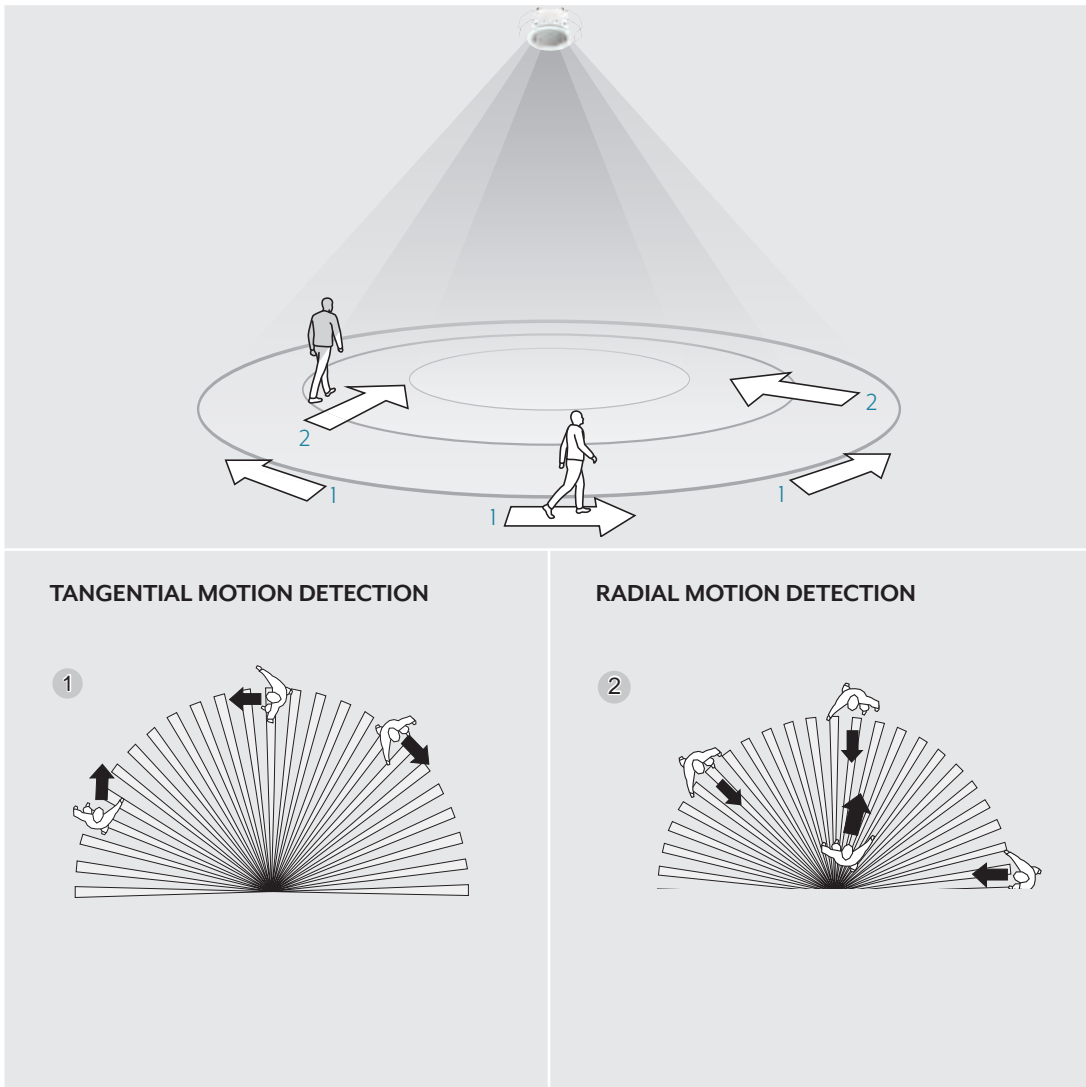

(1) Range for tangential movement on the floor

(2) Range for radial movement on the floor

### Motion detector Mini Basic: Installation in the hotel room

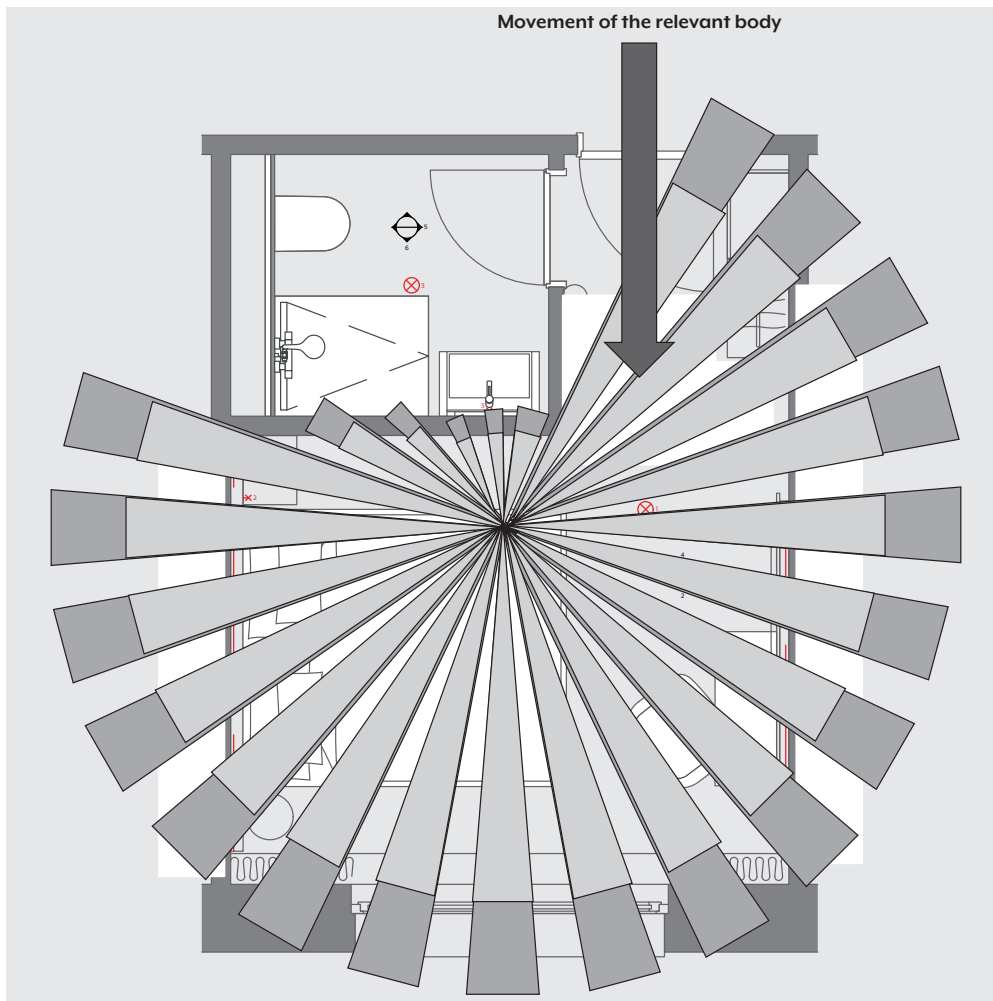

The sketched beams illustrate the detection range of the sensor:  
The motion detector placed in the front part of the hotel room covers the entire room as well as a large area of the entrance area with its sensor field.

### **9.5.1 Adjustment of the parameters for automatic switches / ceiling observers / presence detectors**

The automatic switches and ceiling observers / presence detectors can be mounted in various positions for a wide range of applications. The setting parameters can be individually adjusted so that they precisely match the individual application purpose and installation location. Further details can be found in the respective operating manual.

#### **SHUT-OFF DELAY**

Using the shut-off delay, you control how long the lighting remains switched on after each motion detection.

For the Standard automatic switches, the shut-off delay is set to two minutes and cannot be changed. The shut-off delay of the Universal automatic switches can be set from 10 seconds to 60 minutes via the Clever Config app.

The Universal automatic switches also have a dynamic self-learning shut-off delay. This optimises energy efficiency and user comfort of the automatic switching.

#### **SENSITIVITY**

Set the sensitivity individually to adjust the range of the automatic switches as required and to prevent incorrect switching due to over-sensitive monitoring. The sensitivity of the individual infrared sensors for the Universal automatic switches can also be adjusted using the Clever Config app. This does not apply for the motion Detector Mini Basic.

#### **BRIGHTNESS THRESHOLD**

Each application needs a different switch-on brightness. You set this via the adjustment of the brightness threshold.

#### **WALKING TEST**

Use the walking test function to check the detection range and the detection behaviour. The walking test is performed independently of brightness.

#### **SAVE SWITCH-ON BRIGHTNESS (MEMORY VALUE)**

In combination with a dimming insert, you can save an individual switch-on brightness. You can adjust the brightness as required using centre plates or conveniently using the Clever Config app or IR remote control (see operating instructions DWPMK 360 ..).

## 9.6 Accessories

Automatic switches and ceiling observers / presence detectors provide energy-efficient lighting in a wide variety of locations in the hotel. Additional components are available for individual use.

### SEALING GASKET



**DESCRIPTION**

for automatic switch 1.1 m,  
to achieve protection level IP 44

**REF. NO.**

551 WU

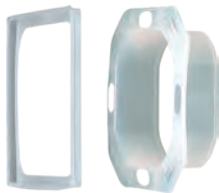
### SEALING KIT

**DESCRIPTION**

for automatic switch 2.2 m,  
to achieve protection level IP 44

**RANGE**

A / AS range  
CD/LS range

**REF. NO.**

AS A 50 DS

AS CD 50 DS

### PROTECTION CAGE

**REF. NO.**

SK 180-90 WW

### SURFACE-MOUNTED HOUSING

**REF. NO.**

PM-KAPPE and  
PM-KAPPE-AL

## 9.7 KNX automatic switches and presence detectors

In addition to the conventional automatic switches and presence detectors, JUNG also provides KNX components. These are part of the ETS product family of physical sensors. The programming into the KNX system of a modern hotel opens further possibilities of building automation.



## 9.7.1 Device Overview

INSERTS	REFERENCE NUMBER
KNX bus coupling unit 3	2073 U

ATTACHMENTS	RANGE	REFERENCE NUMBER
Standard KNX automatic switch 1.1 m		.. 3181 ..
Standard KNX automatic switch 2.2 m	A	.. 3281 ..
Universal KNX automatic switch 1.1 m	AS	.. 3181-1 ..
Universal KNX automatic switch 2.2 m	CD	.. 3281-1 ..
	LS	.. 3281-1 ..
KNX presence detector Mini Standard with integrated BCU (bus coupling unit)		3361 M WW ..
KNX presence detector Mini Universal with integrated BCU (bus coupling unit)		3361-1 M WW
KNX brightness controller Mini with integrated BCU (bus coupling unit)		2096 LUX
KNX standard presence detector / ceiling observer with integrated BCU (bus coupling unit)		3361 ..
KNX presence detector / ceiling observer Universal with integrated BCU (bus coupling unit)		3361-1 ..
Motion detector Mini Basic		BM 360 MB

ACCESSORIES	RANGE	REFERENCE NUMBER
IR remote control for KNX automatic switch and presence detector Universal		KNX PM FB IR
Sealing kit for automatic switch 2.20 m, to achieve protection level IP 44	A/AS	AS A 50 DS
	CD/LS	AS CD 50 DS
Sealing gasket for automatic switch 1.10 m, to achieve protection level IP 44		551 WU
Protection cage		SK 180-90 WW
Flush mounting set		PMM-UP-SET-WW
Surface mounting set		PMM-AP-SET-WW
Surface-mounted housing		PM-KAPPE- ..

## 9.7.2 KNX bus coupling unit insert

An insert is required to use the JUNG KNX Standard and Universal automatic switches. The KNX bus coupling unit 3 is mounted in wall boxes according to DIN 49073.

### KNX BUS COUPLING UNIT 3 2073 U



#### CONNECTION AND FUNCTIONS

Attachments	.. 3181 .. / .. 3281 ..
KNX medium	TP 256
KNX rated voltage	21 ... 32 V DC SELV
Ambient temperature	-25 ... +55 °C
Storage / transport temperature	-25 ... +70 °C
Connection	Screw fastening, without fastening claws
Protection class	
Number of satellite units	unlimited
Function	- Coupling KNX application modules with programming button to KNX systems



### 9.7.3 Installation and electrical connection of KNX bus coupling unit 3

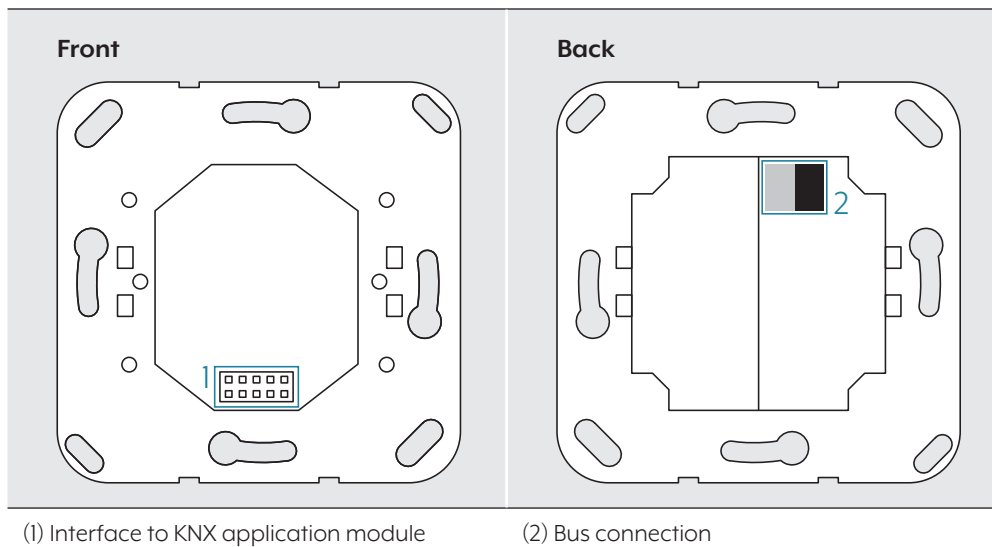

**Observe installation position. Observe TOP marking.**

1. Connect the device to the bus line using the bus connection terminal (2). Red = +, black = -.
2. Mount the device in the wall box.
3. Attach the KNX application module.

### 9.7.4 KNX automatic switch 1.1 m Standard

The KNX automatic switches 1.1 m Standard are exclusively designed for use in dry indoor rooms. The extension with a sealing gasket is not possible.

#### A RANGE



MATERIAL	COLOUR	REF. NO.
Thermoplastic (breakproof) high-gloss	ivory	THE A 3181
	white	A 3181 WW
	black	A 3181 SW

MATERIAL	COLOUR	REF. NO.
Thermoplastic (breakproof) lacquered	aluminium	A 3181 AL
	champagne	A 3181 CH
	mocha	A 3181 MO
	matt anthracite	A 3181 ANM

#### CD RANGE



MATERIAL	COLOUR	REF. NO.
Thermoplastic (breakproof) high-gloss	ivory	CD 3181
	white	CD 3181 WW
	grey	CD 3181 GR
	light grey	CD 3181 LG
	black	CD 3181 SW

#### LS RANGE



MATERIAL	COLOUR	REF. NO.
Thermoplastic (breakproof) high-gloss	ivory	LS 3181
	white	LS 3181 WW
	light grey	LS 3181 LG
	black	LS 3181 SW

MATERIAL	COLOUR	REF. NO.
Lacquered metal versions	aluminium	AL 3181
	stainless steel	ES 3181
	anthracite	AL 3181 AN
	dark	AL 3181 D
	classic brass	ME 3181 C
	antique brass	ME 3181 AT

## 9.7.5 KNX automatic switch 1.1 m Universal

The KNX automatic switches 1.1 m Universal are exclusively designed for use in dry indoor rooms. The extension with a sealing gasket is not possible.

### A RANGE



MATERIAL	COLOUR	REF. NO.
Thermoplastic (breakproof) high-gloss	ivory	A 3181-1
	white	A 3181-1 WW
	black	A 3181-1 SW

MATERIAL	COLOUR	REF. NO.
Thermoplastic (breakproof) lacquered	aluminium	A 3181-1 AL
	champagne	A 3181-1 CH
	mocha	A 3181-1 MO
	matt anthracite	A 3181-1 ANM

### CD RANGE



MATERIAL	COLOUR	REF. NO.
Thermoplastic (breakproof) high-gloss	ivory	CD 3181-1
	white	CD 3181-1 WW
	brown	CD 3181-1 BR
	grey	CD 3181-1 GR
	light grey	CD 3181-1 LG
	black	CD 3181-1 SW

### LS RANGE



MATERIAL	COLOUR	REF. NO.
Thermoplastic (breakproof) high-gloss	ivory	LS 3181-1
	white	LS 3181-1 WW
	light grey	LS 3181-1 LG
	black	LS 3181-1 SW

MATERIAL	COLOUR	REF. NO.
Lacquered metal versions	aluminium	AL 3181-1
	stainless steel	ES 3181-1
	anthracite	AL 3181-1 AN
	dark	AL 3181-1 D
	classic brass	ME 3181-1 C
	antique brass	ME 3181-1 AT

### 9.7.6 Installation and electrical connection of KNX automatic switch 1.1 m

1. Make sure that the mounting location is free of vibrations.
2. For optimum range, select the mounting location tangential to the direction of movement (a detailed description of the range can be found in the operating manual KNX Standard Automatic Switch ref. no ... 3181 ... and ... 3181-1 ..).
3. Avoid sources of interference in the detection range.
4. Connect the bus coupling unit (3) correctly.
5. Plug the attachment (3) with frame (2) onto the bus coupling unit 3 (1).

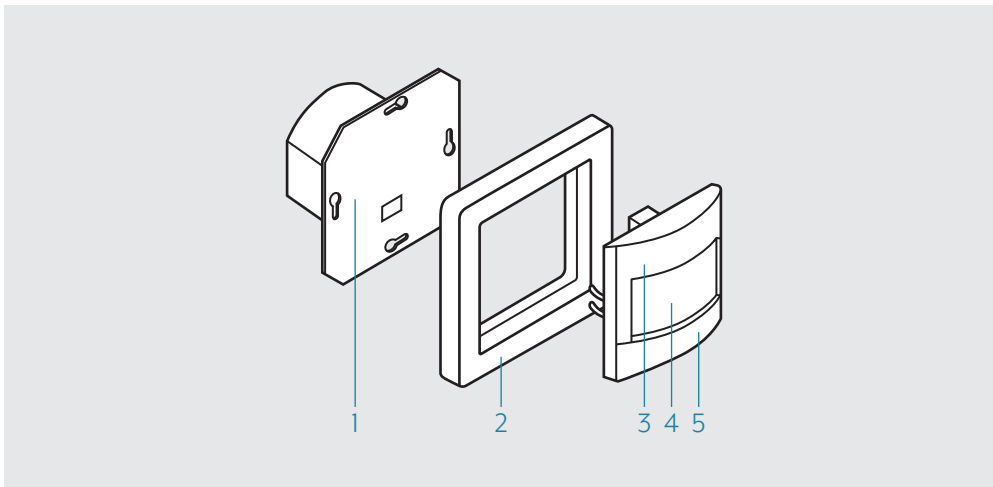

6. You can reduce the detection field by using a shutter. The detection field can be extended by using additional KNX automatic switches with bus coupling unit 3.
7. The device is programmed using KNX-certified software.

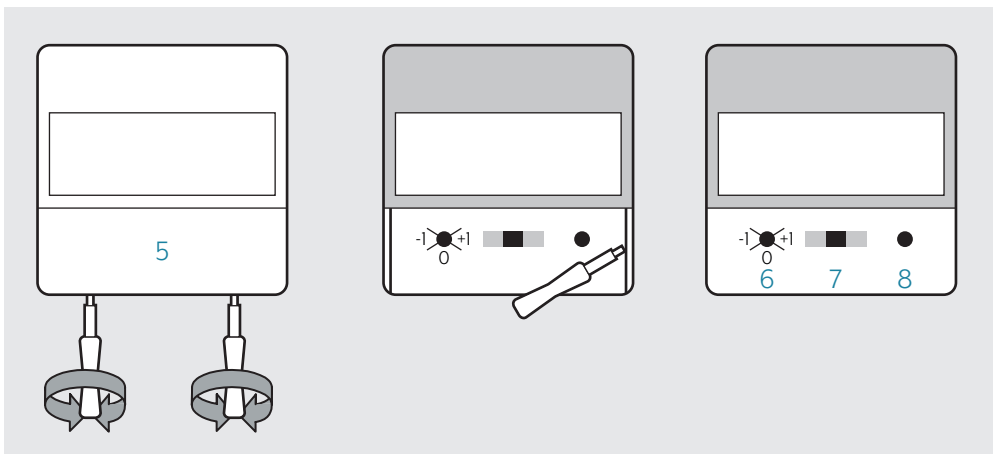

8. Carefully pull the cover off the sliding switch (5).
9. Press the programming button (8). The red LED in the lens lights.
10. Allocate the physical address using the programming software. The red LED extinguishes.
11. Label the device with the physical address.
12. Load the application program into the device.
13. The detection sensitivity can be corrected with the SENS adjuster (6), if required.

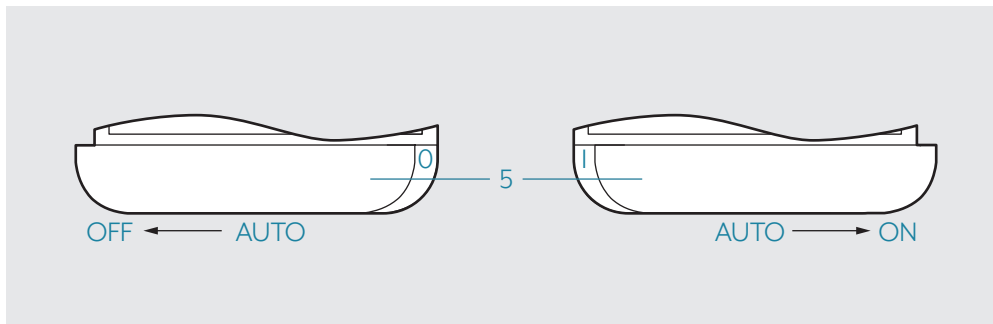

14. Manual control (Continuous ON or Continuous OFF) is possible at the sliding switch (5).

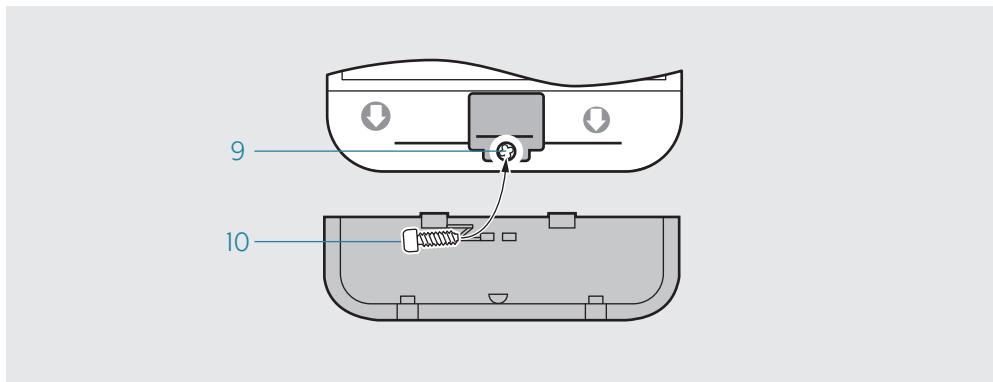

15. If necessary, the sliding switch can be mechanically locked in the AUTO position. To do this, move the sliding switch to the AUTO position. Screw the locking screw (10) into the hole (9) of the sliding switch.
16. Carefully reattach the cover.
17. The KNX Universal automatic switch can also be operated via an IR remote control, which is available as an accessory. The exact description can be found in the operating manual KNX Standard Automatic Switch ref. no. ... 3181 ... and ... 3181-1 ...



## 9.77 KNX automatic switch 2.2 m Standard

The IP 44 protection level is ensured with the sealing kit AS A/CD 50 DS and range-specific IP 44 frames.

### A RANGE



MATERIAL	COLOUR	REF. NO.
Thermoplastic (breakproof) high-gloss	ivory	THE A 3281
	white	A 3281 WW
	black	A 3281 SW

MATERIAL	COLOUR	REF. NO.
Thermoplastic (breakproof) lacquered	aluminium	A 3281 AL
	champagne	A 3281 CH
	mocha	A 3281 MO
	matt anthracite	A 3281 ANM

### CD RANGE



MATERIAL	COLOUR	REF. NO.
Thermoplastic (breakproof) high-gloss	ivory	CD 3281
	white	CD 3281 WW
	grey	CD 3281 GR
	light grey	CD 3281 LG
	black	CD 3281 SW

### LS RANGE



MATERIAL	COLOUR	REF. NO.
Thermoplastic (breakproof) high-gloss	ivory	LS 3281
	white	LS 3281 WW
	light grey	LS 3281 LG
	black	LS 3281 SW

MATERIAL	COLOUR	REF. NO.
Lacquered metal versions	aluminium	AL 3281
	stainless steel	ES 3281
	anthracite	AL 3281 AN
	dark	AL 3281 D
	classic brass	ME 3281 C
	antique brass	ME 3281 AT

## 9.7.8 KNX automatic switch 2.2 m Universal

The IP 44 protection level is ensured with the sealing kit AS A/CD/LS 50 DS and range-specific IP 44 frames.

### A RANGE



MATERIAL	COLOUR	REF. NO.
Thermoplastic (breakproof) high-gloss	ivory	A 3281-1
	white	A 3281-1 WW
	black	A 3281-1 SW

MATERIAL	COLOUR	REF. NO.
Thermoplastic (breakproof) lacquered	aluminium	A 3281-1 AL
	champagne	A 3281-1 CH
	mocha	A 3281-1 MO
	matt anthracite	A 3281-1 ANM

### CD RANGE



MATERIAL	COLOUR	REF. NO.
Thermoplastic (breakproof) high-gloss	ivory	CD 3281-1
	white	CD 3281-1 WW
	grey	CD 3281-1 GR
	light grey	CD 3281-1 LG
	black	A 3281-1 SW

### LS RANGE



MATERIAL	COLOUR	REF. NO.
Thermoplastic (breakproof) high-gloss	ivory	LS 3281-1
	white	LS 3281-1 WW
	light grey	LS 3281-1 LG
	black	LS 3281-1 SW

MATERIAL	COLOUR	REF. NO.
Lacquered metal versions	aluminium	AL 3281-1
	stainless steel	ES 3281-1
	anthracite	AL 3281-1 AN
	dark	AL 3281-1 D
	classic brass	ME 3281-1 C
	antique brass	ME 3281-1 AT

### 9.7.9 Installation and electrical connection of KNX automatic switch 2.2 m

1. Make sure that the mounting location is free of vibrations.
2. For optimum range, select the mounting location tangential to the direction of movement (a detailed description of the range can be found in the operating manual KNX Standard Automatic Switch ref. no ... 3281 ... and ... 3281-1 ..).
3. Avoid sources of interference in the detection range.
4. Connect the bus coupling unit 3 (l) correctly.
5. Further installation steps are necessary to ensure IP44 protection (see instructions for sealing kit).
6. Plug the attachment (3) with frame (2) onto the bus coupling unit 3 (l).

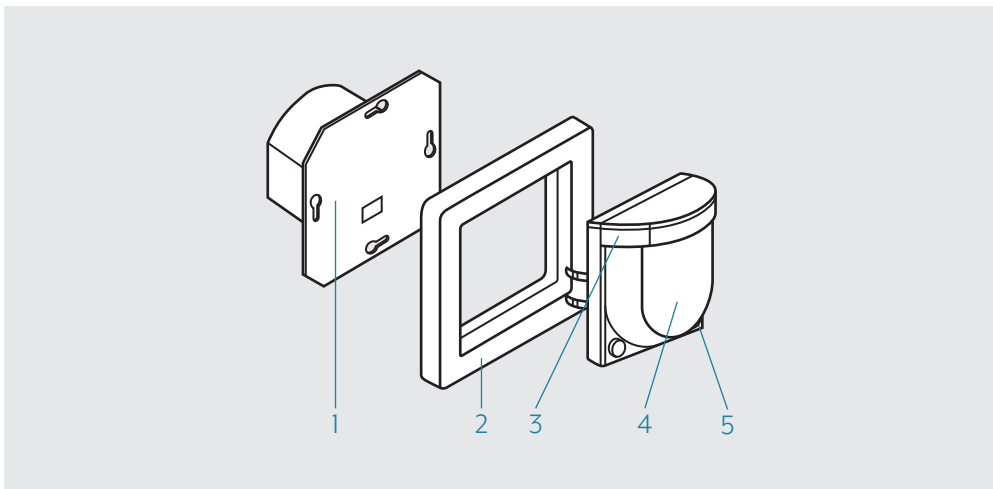

7. The detection field can be extended by using additional KNX automatic switches with bus coupling unit 3.
8. The device is programmed using KNX-certified software.
9. Press and hold the AUTO / I button (5) for approx. 5 seconds until the red LED in the lens (4) lights.
10. Allocate the physical address using the programming software. The red LED extinguishes.
11. Label the device with the physical address.
12. Load the application program into the device.

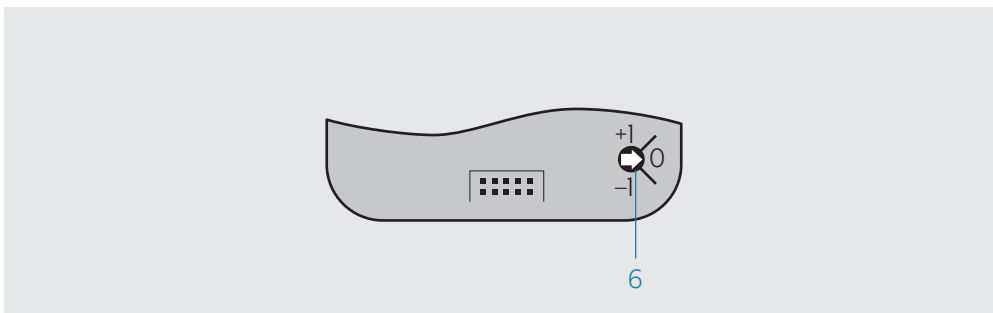

13. The detection sensitivity can be corrected with the SENS adjuster (6), if required.
14. The KNX automatic switch Universal can also be operated via an IR remote control, which is available as an accessory. The exact description can be found in the operating manual KNX Standard Automatic Switch ref. no. .. 3281 .. and .. 3281-1 ..



### 9.7.10 KNX ceiling observer / presence detector

The KNX ceiling observers / presence detectors are programmed using KNX-certified software. Subsequent fine adjustment of the settings is also possible for the Universal versions via IR remote control (ref no.: KNX PM FB IR).

#### KNX PRESENCE DETECTOR MINI WITH INTEGRATED BCU (BUS COUPLING UNIT)



	COLOUR	REF. NO.
<b>Standard</b>	white	3361 M WW
<b>Universal</b>	white	3361-1 M WW

The KNX presence detector Mini with integrated BCU (bus coupling unit) controls lighting, room thermostats and other electrical consumers in indoor rooms as needed. It is designed for clamp mounting in suspended ceilings. Mounting on fixed ceilings in a mounting box according to DIN 49073 is also possible with the flush-mounting set (ref. no. PMM-UP-SET-WW). Surface mounting on the ceiling is possible with the surface-mounted housing (ref. no.: PMM-AP-SET-WW).

#### MOTION DETECTOR MINI BASIC



	COLOUR	REF. NO.
	white	BM 360 MB

The motion detector Mini Basic is designed as a node in KNX systems, e.g. with a KNX Multistation or with a KNX push-button interface. The device is based on the KNX presence detector Mini, but is only suitable for motion detection.

#### KNX BRIGHTNESS CONTROLLER MINI WITH INTEGRATED BCU (BUS COUPLING UNIT)



	COLOUR	REF. NO.
	white	2096 LUX

The KNX brightness controller Mini with integrated BCU (bus coupling unit) measures and controls the lighting indoors or in protected outdoor areas. It is designed for clamp mounting in suspended ceilings. Mounting on fixed ceilings in a mounting box according to DIN 49073 is also possible with the flush-mounting set (ref. no. PMM-UP-SET-WW). Surface mounting on the ceiling is possible with the surface-mounted housing (ref. no.: PMM-AP-SET-WW).

## Accessories for the KNX Presence Detector Mini and KNX Brightness Controller Mini

### FLUSH MOUNTING SET



		REF. NO.
Design ring Ø, inner	35.6 mm	PMM-UP-SET-WW
Design ring Ø, outer	80 mm	
Design ring installation height	3 mm	
Lens installation height	6.6 mm	

for ceiling mounting; for installation in wall box according to DIN 49073

### SURFACE MOUNTING SET



		REF. NO.
Dimensions (Ø x H)	80 / 83 x 49 mm (including design ring)	PMM-AP-SET-WW
Design ring Ø, outer	80 mm	
Design ring Ø, inner	35.6 mm	
Design ring Ø, outer	80 mm	

for ceiling mounting

### KNX PRESENCE DETECTOR / CEILING OBSERVER WITH INTEGRATED BCU (BUS COUPLING UNIT)



	COLOUR	REF. NO.
<b>Standard</b>	white	3361 WW
	aluminium (lacquered)	3361 AL
<b>Universal</b>	white	3361-I WW
	aluminium (lacquered)	3361-I AL

Housing material: Plastic

The KNX presence detector / ceiling observer with integrated BCU (bus coupling unit) is designed for ceiling mounting in flush-mounting boxes according to DIN 49073. Surface mounting with the surface-mounted housing (ref. no.: PM-Kappe ..) is possible. The KNX presence detector / ceiling observer is mainly used for actively used areas of the hotel, e.g. the fitness area or utility rooms, as it can be protected against damage with a protective cage (ref. no.: SK 180-90 WW).

### 9.7.11 Installation and electrical connection of KNX presence detector mini and KNX brightness controller mini

The KNX presence detector mini and the KNX brightness controller mini are designed for installation in false ceilings. Mounting in flush-mounted boxes according to DIN 49073 or with a surface-mounted housing is possible. For this, please refer to the operating manuals KNX Presence Detector Mini ref. no. 3361 ... M WW and KNX Brightness Controller Mini ref. no.: 2092 LUX.

1. Make sure that the mounting location is free of vibrations.
2. For optimum range, select an interference-free installation location (a detailed description can be found in the operating manuals KNX Presence Detector Mini ref. no. 3361 ... M WW and KNX Brightness Controller Mini ref. no.: 2092 LUX).

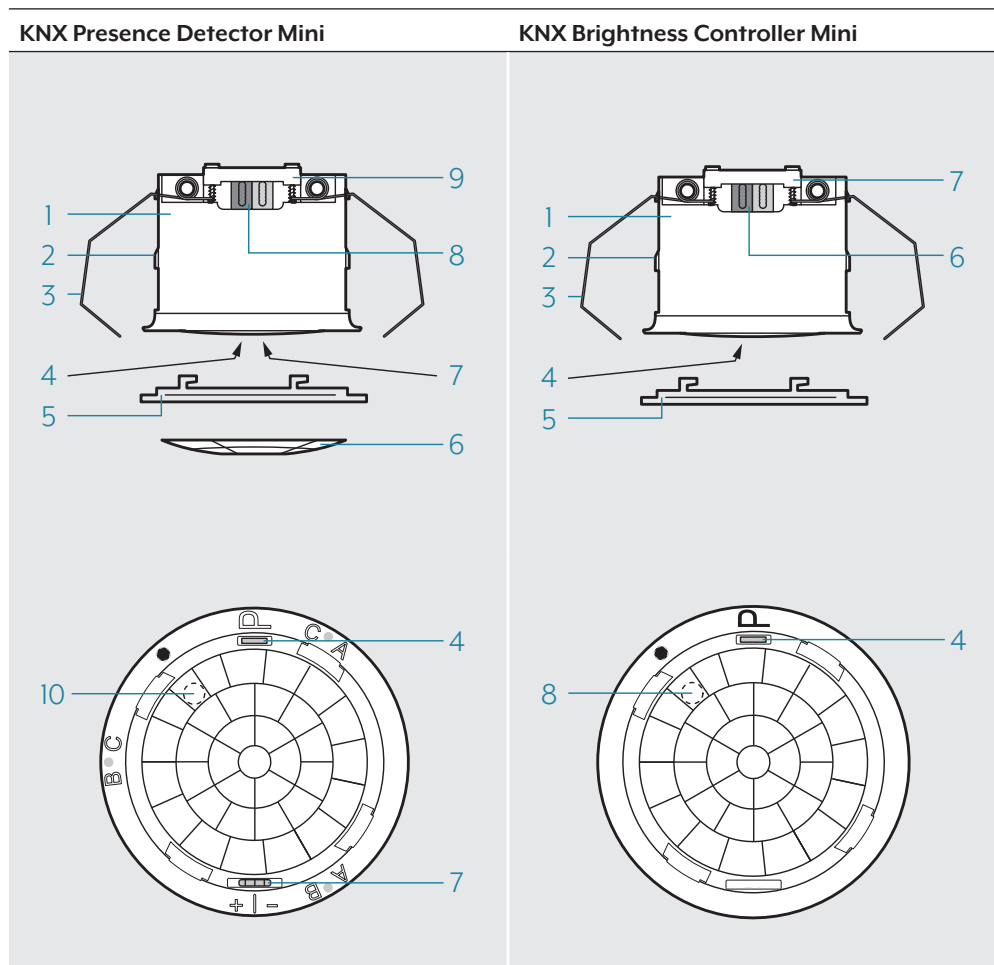

- (1) Presence detector
- (2) Guide for clamping springs
- (3) Spring clamp
- (4) Programming button, red
- (5) Design ring
- (6) Shutter
- (7) Sensitivity switch, blue
- (8) Bus connection
- (9) Cable fastener
- (10) Brightness sensor

- (1) Brightness controller
- (2) Guide for clamping springs
- (3) Spring clamp
- (4) Programming button, red
- (5) Design ring
- (6) Bus connection
- (7) Cable fastener
- (8) Brightness sensor

3. The environment in the false ceiling must be dry.  
Max. thickness of the false ceiling approx. 25 mm, minimum installation depth 35 mm.  
The distance between the concrete and the false ceiling must be at least 20 mm. Ceiling cut-out 44...45 mm.
4. Connect the bus cable and clamp the bus cable with cable fastener (9) and (7).
5. Bend the spring clamp (3) back and push the device (1) into the false ceiling.
6. Attach the design ring (5) and turn it clockwise.

### PROGRAMMING

The device is programmed using KNX-certified software.

1. Connect the device.
2. Make sure that the device is operational.  
If the device is mounted, remove the design ring.
3. Switch on the bus voltage.
4. Press the red programming button (4); LED in the sensor window lights.
5. Allocate the physical address; LED extinguishes.
6. Label the device on the side with the physical address.
7. Load the application software into the device.
8. Check the detection ranges of each KNX device connected in parallel using the software.  
Further details can be found in the operating manuals KNX Presence Detector Mini ref. no. 3361 ... M WW and KNX Brightness Controller Mini ref. no.: 2092 LUX.
9. An additional fine adjustment is possible for the KNX Presence Detector Mini Universal version with an IR remote control available as an accessory. The exact description can be found in the operating manual KNX Presence Detector Mini ref. no. 3361 ... M WW.

### 9.7.12 Installation and electrical connection of KNX presence detector / ceiling observer

The KNX presence detector / ceiling observer is designed for mounting in flush mounting wall boxes according to DIN 49073. Mounting with a surface-mounted housing is possible. For this, please refer to the operating manual KNX Presence Detector / Ceiling Monitor ref. no. 3361 ...

1. Make sure that the mounting location is free of vibrations.
2. For optimum range, select an interference-free installation location (a detailed description can be found in the operating manual KNX Presence Detector / Ceiling Observer ref. no. 3361 ..).

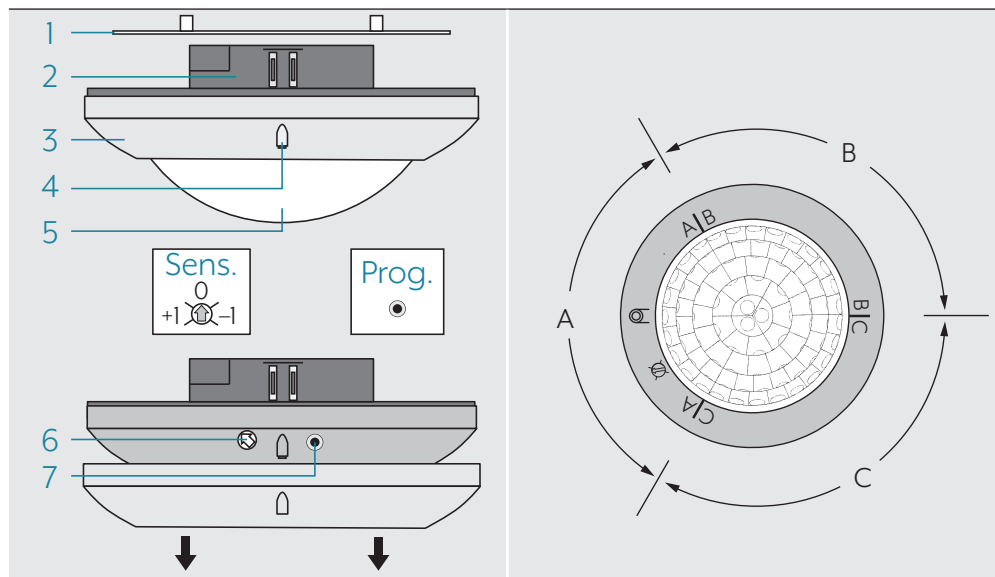

- |   |   |
|---|---|
| <ol style="list-style-type: none"> <li>(1) Supporting ring</li> <li>(2) Integrated BCU (bus coupling unit)</li> <li>(3) Decorative ring</li> <li>(4) Brightness sensor</li> </ol> | <ol style="list-style-type: none"> <li>(5) Sensor window with programming LED, red and status LED, blue</li> <li>(6) Sensor adjuster for manual sensitivity correction</li> <li>(7) Programming button Prog.</li> </ol> |
|---|---|

Requirements: Flush-mounted device box is installed at the intended installation location on the room ceiling.

3. Pull off the decorative ring (3).
4. Mount the support ring (1) so that the areas A, B and C are correctly aligned.
5. Guide the bus cable through the support ring.
6. Connect the bus cable using the terminal to the bus connection on the back of the device.
7. Press the correctly aligned device into the support ring until it engages.
8. Attach the decorative ring (3).

#### PROGRAMMING

The device is programmed using KNX-certified software.

1. Switch on the bus voltage.
2. Press the programming button (7); LED in the sensor window lights.
3. Allocate a physical address; LED extinguishes.
4. Label the device on the side with the physical address.
5. Load the application software into the device.
6. Check the detection ranges of each KNX device connected in parallel using the software. Further details about this and the fine adjustment via IR remote control, which is available as an accessory, can be found in the operating manual KNX Presence Detector / Ceiling Observer ref. no. 3361 ...

## 9.8 Motion detector Mini Basic

Two possible use cases in which the motion detector Mini Basic is used are in a simple guest room and presence monitoring in a luxury hotel room. Use Case 1 shows the use of the motion detector Mini Basic, which is connected to the KNX Multistation. In Use Case 2, the motion detector Mini Basic is connected to the KNX push-button interface. The complete parametrisation is performed in the respective KNX product to ensure easy commissioning and maintenance.



### 9.8.1 Use Case I – Guest room

Instead of a key card holder, the motion detector Mini Basic together with a KNX Multistation takes over the presence detection. This can be used to switch electrical consumers (here lighting) and electrothermal drives (heating or air conditioning). Electrically operated blinds, shutters and awnings can also be triggered.

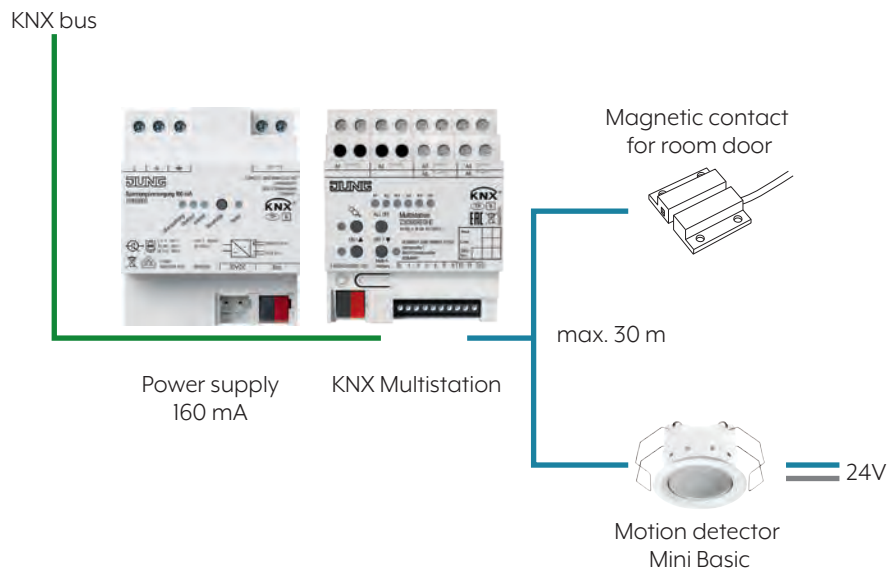
In addition to the hotel room, further applications are also possible in offices, conference rooms, public washrooms as well as corridors and passages.

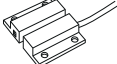

#### NECESSARY COMPONENTS

	NAME	REF. NO.
	JUNG 160 mA power supply	20160 REG
	JUNG KNX Multistation	23066 REGHE
	JUNG motion detector Mini Basic	BM 360MB WW
	JUNG magnetic contact	FUS 4410 WW

## SCENARIO

If the motion detector Mini Basic detects the presence of a person, the room is "occupied" and the connected Multistation starts the integrated "Welcome" logic. Various actions are performed, such as the regulation of the air conditioning control in the "Comfort " mode and the activation of a predefined light scene.

If no presence is detected, the room is "not occupied" and the connected Multistation starts the "Goodbye" logic. Depending on the request, this switches the air conditioning to the "Standby" or "Eco" operating mode.

Optionally, a delay for switching the lighting on or off can be configured. The result of the lighting control is then not output until the set time has elapsed. If the motion detector Mini Basic is combined with the KNX Multistation, further switching options are available: SCENES, OPERATING MODES and SWITCHING OPERATIONS can be triggered with the KNX Multistation.

## LIGHTING CONTROL

The lighting control is available as a configuration template for logic functions. Lighting control can be activated as an alternative to the user-defined configuration for logic functions 1 and 2 and enables a "Welcome" or "Goodbye" control for the light in a hotel room etc. Defined inputs and outputs are available.

### Functionality

The lighting control distinguishes between the "Welcome" (welcoming light) and "Goodbye" (light completely OFF) applications. The parameter "Type of logic function" on the parameters page "Logic functions -> LO... - General" defines the functionality.

### Welcome

When entering a room or building, the lighting is specifically switched on, triggered by the 1-bit switching telegram of the motion detector BM 360 MB, provided that it is completely switched off. The polarity of the switching telegram for activation of the lighting (ON, OFF) can be configured. The controller uses the optional 8 or 15 lighting inputs to detect whether luminaires are switched on in the room. The "Welcome" function is only executed if all luminaires are switched off (all lighting inputs = "OFF") and the light should be switched on when the room is entered. Ideally, the 1-bit feedback objects of the KNX actuator channels of the lighting to be evaluated are each linked to a lighting input of the controller. The 1-bit result object selected in the result stage is used to switch on the lighting for a "Welcome".

### Goodbye

When leaving a room or building, the lighting is switched off centrally, triggered by the 1-bit switching telegram of the motion detector BM 360 MB, provided that it is completely or partially switched on. The polarity of the switching telegram for deactivation of the lighting (ON, OFF) can be configured. The controller uses the optional eight or 15 lighting inputs to detect whether all or individual luminaires are switched on in the room.

The "Goodbye" function is only executed if at least one luminaire is switched on (min. one lighting input = "ON") and the light should be switched off when leaving the room. Ideally, the 1-bit feedback objects of the KNX actuator channels of the lighting to be evaluated are also each linked to a lighting input of the controller. The 1-bit result object selected in the result stage is used to switch off the lighting for a "Goodbye".

### 9.8.2 Use Case 2 – Presence monitoring with motion detector – Luxury hotel room



Instead of a key card holder, the motion detector Mini Basic, together with a KNX power supply with IP interface, takes over the presence detection. The power supply is operated by the communication objects of the push-button interface. This can be used to trigger light scenes and operating modes (e.g. air conditioning, underfloor heating, etc.) in hotel rooms, for example:

- A. Light scene 1: With 50% light in the bathroom, 100% light at the bed; operating mode 1: "Comfort"
- B. Light scene 2: "All Off"; operating mode 2: "Eco".

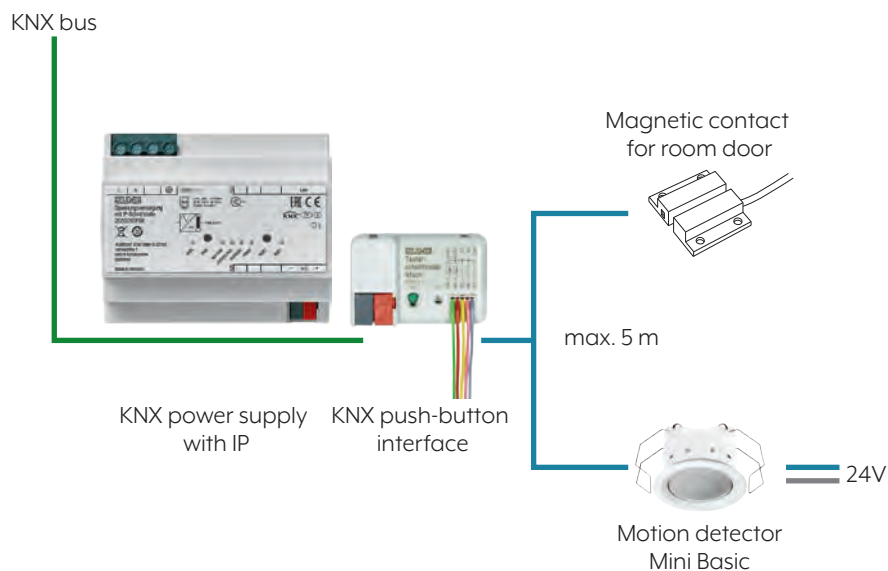
In addition to the hotel room, further applications are also possible in offices, conference rooms, public washrooms as well as corridors and passages.

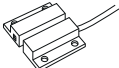

#### NECESSARY COMPONENTS

	NAME	REF. NO.
	JUNG KNX power supply with IP interface, 320 mA	20320 IS IPS R
	JUNG KNX push-button interface, 4-gang	2076-4 T
	JUNG motion detector Mini Basic	BM 360MB WW
	JUNG magnetic contact	FUS 4410 WW



## SCENARIO

A person enters the room for the first time (First Entry) (door contact is activated), thereby triggering a "Welcome" scene. The lighting is switched on dimmed (additional dimming actuator required).

If the presence detector detects presence within the presence activation time, the "Comfort" operating mode can be activated, the blinds moved to the upper end position (an additional blind actuator would be required for this) and supplementary lighting dimmed.

A different scene is triggered if the presence detector does not detect presence within the activation time. The lighting is switched off ("All Off").

If another person enters the room (door contact is activated again), a "Night Light" scene is triggered: The entrance lighting is dimmed to minimum brightness.

An operating mode is transmitted if a person leaves the room and no presence is detected after a delay time. For example, the "Standby" operating mode can be activated. A "Goodbye" scene is triggered after the activation time, thus switching off the lighting.

## PRESENCE MONITORING WITH MOVEMENT DETECTOR – LUXURY

Trigger 1 activation (e.g. door contact or switch) by	change to "On"
Number of presence detectors (all presence detectors are OR linked)	3
Scene "Welcome" before detection of a presence	√
Activation time "Welcome" (s)	30
Output value (scene) "Welcome"	1
Output value (scene), if presence mode is not activated in this time (no presence detected)	2
Scene "Presence" after detection of a presence	√
Output value (scene) "Presence"	3
Changeover to room controller operating mode after detection of a presence	√
Output value (operating mode)	"Comfort" mode (1)

## PRESENCE MODE

Presence mode describes the state when a door contact is detected, although there is presence in the room.

If trigger 1 is activated again and no presence is detected within a configurable period of time, the lighting is deactivated and the room lighting is deactivated and the room controller switches to "Comfort" or "Standby" mode.

If presence is detected, "Goodbye" is cancelled. Trigger 1 must first be activated again to restart the "Goodbye" loop.

Scene after reactivation of trigger 1, if trigger 2 is already active	√
Output value (scene)	4
Scene "Goodbye" if trigger 1 is activated again and no presence is detected	√
Trigger 2 shut-off delay before calling "Goodbye" scene (s)	240
Output value (scene) "Goodbye"	5
Room controller operating mode changeover "Goodbye"	√
Output value (operating mode)	"Standby" mode (2)





## 10. HEATING AND COOLING

### 10.1 EQUIPMENT OVERVIEW [221](#)

#### 10.1.1 Connection and functions [222](#)

### 10.2 2-PIPE AND 4-PIPE SYSTEMS [224](#)

#### 10.2.1 Connecting 2-pipe fan coil unit [224](#)

#### 10.2.2 Connecting 4-pipe fan coil unit [225](#)

### 10.3 OPERATING MODES AND PROFILES [226](#)

### 10.4 KNX [228](#)

## 10. Heating and cooling

The fan coil room thermostat provides the optimum temperature in the hotel room, whether as a conventional design or as a KNX device. In the switch design and with a high-quality, real glass front, the controller blends harmoniously into its surroundings. Clear displays and unambiguous symbols make it easy for the guest to select the appropriate air conditioning mode for his own comfort.

The requirements for more energy efficiency are met by the “Eco” mode, one of four operating modes. The display is darkened in the idle state so that the sleep of the guest is not disturbed.

### **PROJECT-SPECIFIC CONFIGURATION AND ORDERING**

Are you planning a hotel where the fan coil room thermostat should be used in multiple hotel rooms? JUNG delivers the controllers already pre-configured on request. Simply download the configuration PDF and define the parameters such as display brightness, temperature setpoints or temperature unit. The configuration PDF can be found at <https://www.jung.de/en/6799/solutions/hotel/hotel-room/room/>.

Afterwards, send us the filled in PDF to the specified e-mail address in the document. The fan coil room thermostat will then be produced and configured according to your specifications. All settings can, of course, also be adjusted manually during and/or after installation.

## 10.1 Equipment Overview

<b>ATTACHMENTS</b>	<b>RANGE</b>	<b>REFERENCE NUMBER</b>
Fan coil room thermostat, 2-pipe	AS, A	TRD A 523028 ..
	LS	TRD LS 923028 ..
Fan coil room thermostat, 4-pipe	AS, A	TRD A 523048 ..
	LS	TRD LS 923048 ..
KNX fan coil room thermostat	AS, A	TRD A 5248 ..
	LS	TRD LS 9248 ..

## 10.1.1 Connection and functions

FAN COIL ROOM THERMOSTAT,  
2-PIPE

TRD .. 23028 ..

FAN COIL ROOM THERMOSTAT,  
4-PIPE

TRD .. 23048 ..



## CONNECTION AND FUNCTIONS

		Power supply TRD-NT 2302	Power supply TRD-NT 2304
Power supply			
2-pipe fan coil unit connection		●	●
4-pipe fan coil unit connection			●
Heating / cooling		Heating or cooling	Heating and/ or cooling
8 capacitive sensor buttons		●	●
5 adjustable temperature profiles		●	●
Optionally 4 adjustable operating modes according to KNX standard		–	–
internal temperature sensor		●	●
external temperature sensor can be evaluated		–	–
Satellite unit input for connection of, for example, a key card holder		●	●
Operation as room thermostat satellite unit		--	
Integrated BCU (Integrated bus coupling unit)		–	–
Colour			
white	A range	TRD A 523028 WW	TRD A 523048 WW
	LS range	TRD LS 923028 WW	TRD LS 923048 WW
black	A range	TRD A 523028 SW	TRD A 523048 SW
	LS range	TRD LS 923028 SW	TRD LS 923048 SW

## KNX FAN COIL ROOM THERMOSTAT

TRD ..248 ..



### CONNECTION AND FUNCTIONS

Power supply	Power supply via KNX system 21 ... 32 V	
2-pipe fan coil unit connection	●	
4-pipe fan coil unit connection	●	
Heating / cooling	Heating and/ or cooling	
8 capacitive sensor buttons	●	
5 adjustable temperature profiles	●	
Optionally 4 adjustable operating modes according to KNX standard	●	
internal temperature sensor	●	
external temperature sensor can be evaluated	●	
Satellite unit input for connection of, for example, a key card holder	-	
Operation as room thermostat satellite unit	●	
Integrated BCU (bus coupling unit)	●	
Colour		
white	A range	TRD A 5248 WW
	LS range	TRD LS 9248 WW
black	A range	TRD A 5248 SW
	LS range	TRD LS 9248 SW

## 10.2 2-pipe and 4-pipe systems

Fan coil units are divided into 2-pipe and 4-pipe units depending on the number of pipes. The 2-pipe fan coil units have one supply and one return pipe. The supply pipe can carry hot or cold water. However, the 2-pipe units can either exclusively heat or exclusively cool, depending on which medium flows through the pipe system. 4-pipe fan coil units have two supply and two return pipes and can thus have hot and cold water flowing through them simultaneously. This makes sense particularly in buildings with large temperature differences where cooling and heating functions are required simultaneously (for example, technical room versus wellness area or also hotel rooms facing south versus hotel rooms facing north).

### 10.2.1 Connecting 2-pipe fan coil unit

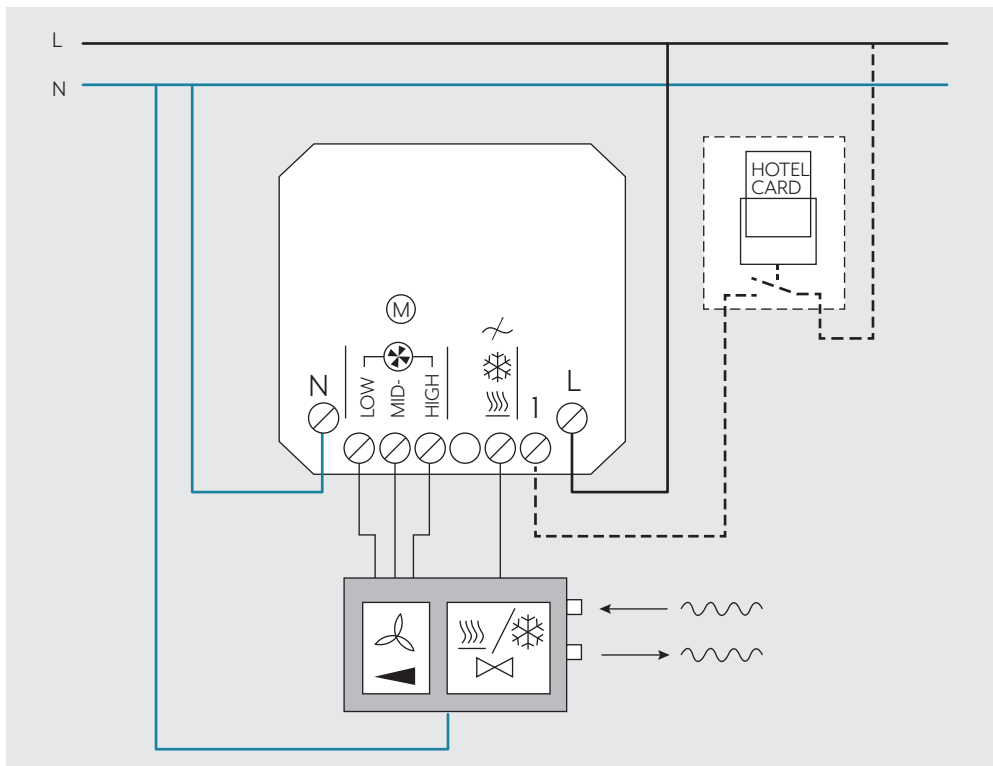





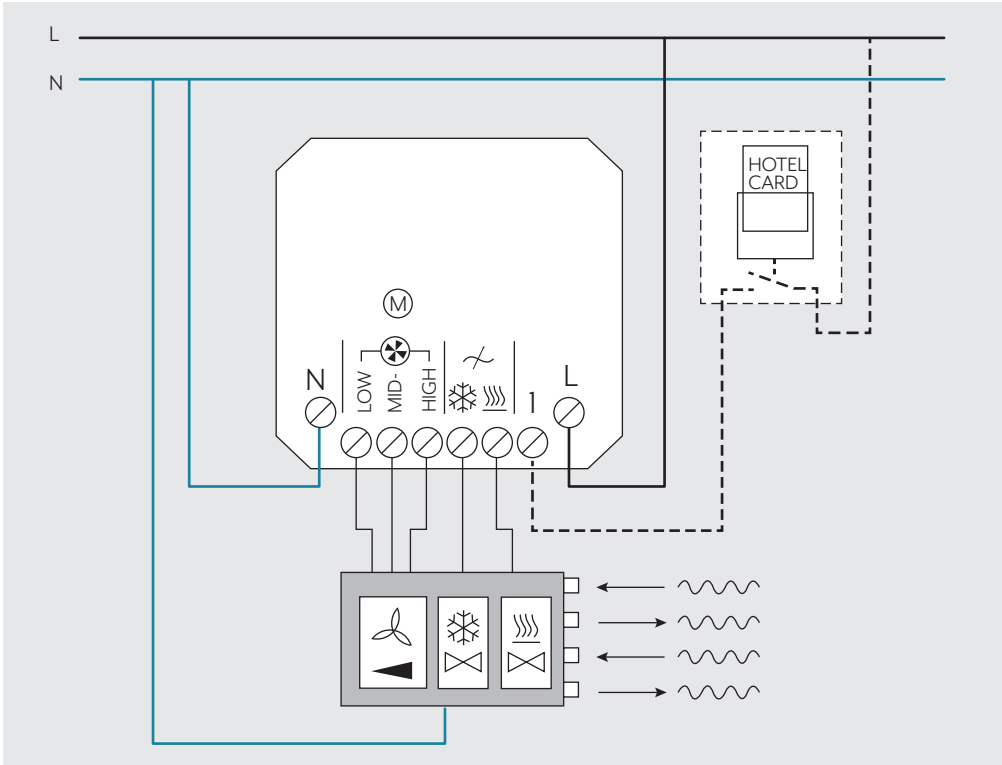

10.2.2 Connecting 4-pipe fan coil unit

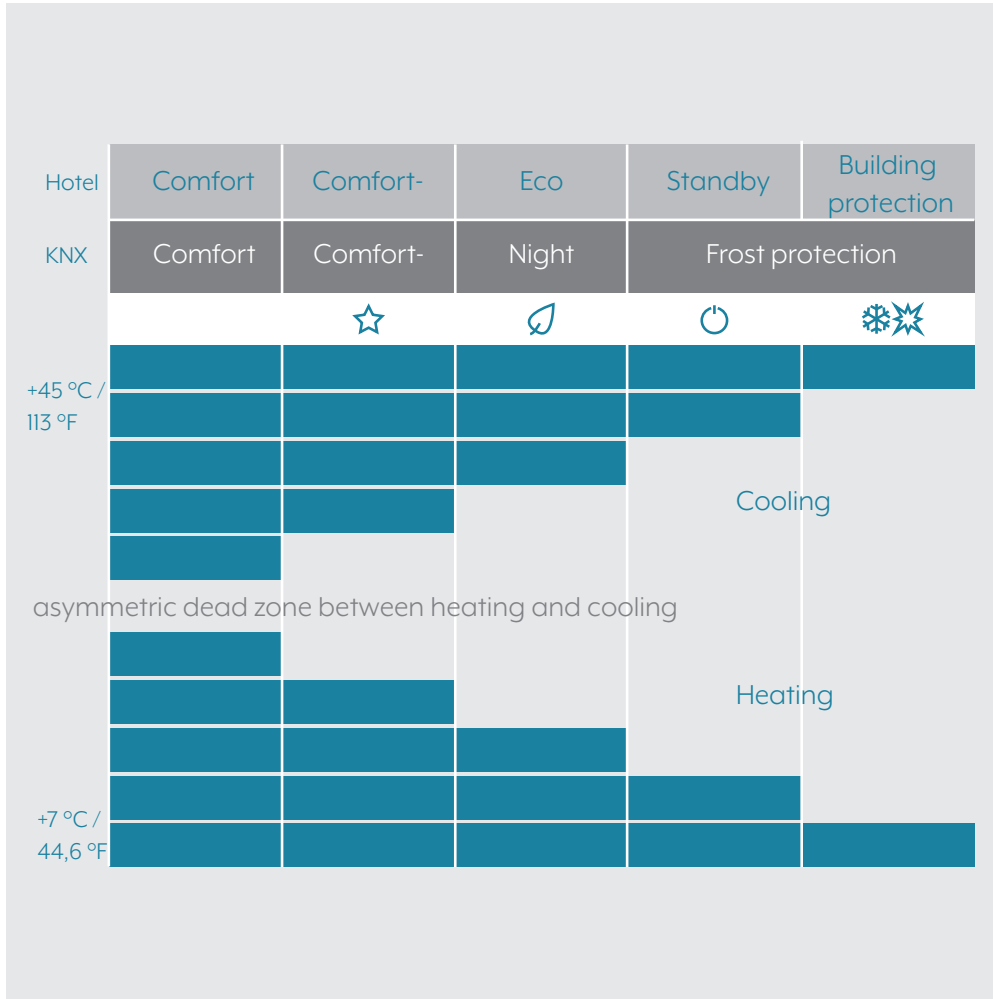

### 10.3 Operating modes and profiles

Different operating modes and profiles are available for the guest. The hotel mode includes the 5 profiles **Comfort**, **Comfort-**, **Eco**, **Standby** and **Building Protection**. In addition to the hotel mode, the KNX fan coil room thermostat can also be switched to KNX mode and then has 4 operating modes: **Comfort**, **Standby**, **Night** and **Frost Protection**.



HOTEL MODE	KNX	DESCRIPTION
Comfort	Comfort	<ul style="list-style-type: none"> <li>- During presence of the guest</li> <li>- Detection by key card or presence detector</li> <li>- Temperature control to Comfort mode</li> </ul>
Comfort- 		<ul style="list-style-type: none"> <li>- During absence of the guest</li> <li>- no detection by key card or presence detector</li> <li>- reduced heating or cooling (lowering of the heating setpoint, increasing the cooling setpoint)</li> </ul>
Eco 		<ul style="list-style-type: none"> <li>- Night mode</li> <li>- can be activated by guest on the room thermostat or via bus</li> <li>- in comparison with Comfort- sustained reduced heating or cooling (lowering the heating setpoint, increasing the cooling setpoint)</li> </ul>
Standby 	Frost protection	<ul style="list-style-type: none"> <li>- Room is not occupied or is reserved or</li> <li>- Guest switches off regulation</li> <li>- can be activated by guest on the room thermostat or via bus</li> <li>- in comparison with Eco sustained reduced heating or cooling (lowering the heating setpoint, increasing the cooling setpoint)</li> </ul>
Building protection 		<ul style="list-style-type: none"> <li>- Controller is almost switched off.</li> <li>- Can be activated via KNX (for example window contact)</li> <li>- Protection during extremely low temperatures (&lt; 7 °C / 44.6 °F) and extremely high temperatures (&gt; 45 °C / 113 °F)</li> </ul>

## 10.4 KNX

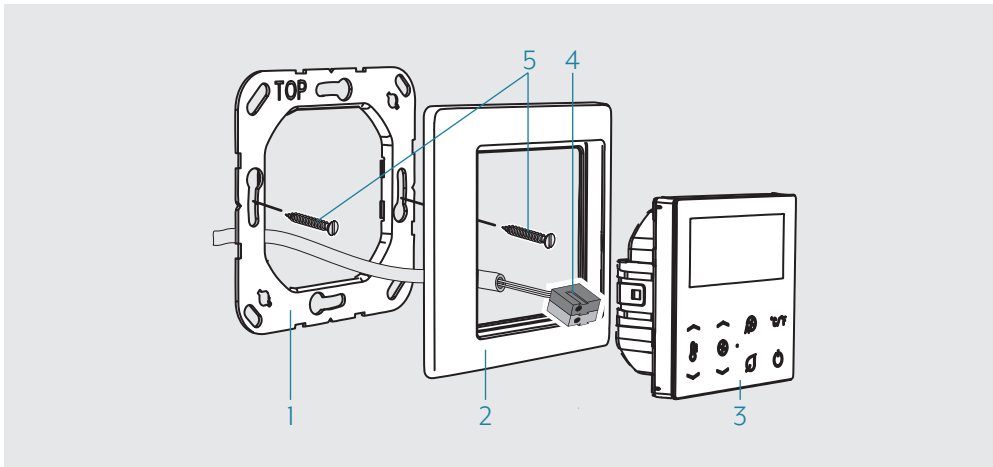

1. Mount the support ring (1) using two screws (5) in a wall box.  
The inscription TOP faces upwards.
2. Put the frame (2) on the support ring.
3. Connect the control panel (3) with the bus terminal to the bus line (4).
4. Put the control panel (3) on the frame (2).

### LOAD PHYSICAL ADDRESS AND APPLICATION PROGRAM

Requirements: The device is connected and the bus voltage is switched on.

1. Press and hold the sensor buttons (^) and (o) simultaneously for approx. 2 seconds.  
The display shows **PRG MODE**. The status LED flashes blue quickly.
2. Allocate the physical address.
3. Load the application program into the device.





## 11. INNOVATION: PLUG + GO

### 11.1 PLUG + GO: THE READY TO PLUG-IN ELECTRICAL INSTALLATION 232

11.1.1 Individual configurations 233

---

11.1.2 The potential savings 235

---

11.1.3 Use in the hotel sector 237

---

# 11. Innovation: plug + go

Sustainability and installation time are key factors for electrical installations in buildings. Among other things, both are optimised by the use of plug-in operating equipment and plug-in installation materials.

The plug + go installations are ideal for use in buildings where rooms are repeated in their furnishings and are therefore recommended for installation in hotels.

plug & go is the clever pre-assembled solution for simple, fast and clean electrical installation in cavity walls and furniture. If required, the system can be adapted at any time and expanded with stylish attachments in the JUNG design.

## 11.1 plug + go: the ready to plug-in electrical installation



plug + go simplifies the daily work of the installers. Furthermore, the ready to plug-in system gives architects and investors planning certainty, as deadlines and costs can be calculated reliably. JUNG provides the basis in pre-production.



Directly after your order, the specialist craftspeople at JUNG start their work: they wire the amount ordered of the required inserts in the individual allocation of flush-mounted boxes. This preparation includes the complete configuration and fixing of the inserts. This involves the use of high-quality technology: while connectors and wiring come from the Wieland and Wago partners, Kaiser supplies the flush-mounting boxes. JUNG builds ready to plug-in installation modules for the customer that fit in the Wieland and Wago system.

Up to four devices can be combined with each other and supplied ready to plug in. JUNG tests the function of the order-specific pre-assembled devices in each case. At the end, they receive the test label "Tested and Approved by JUNG" as a seal of quality. Ordering is simple and convenient using the JUNG website at [www.jung.de/pag](http://www.jung.de/pag). The only thing you have to do on site is to select your desired compilation of plug + go. A special order form is available online for this purpose. Your pre-assembled electrical components then come directly to you. Unpack, fit in the wall, connect the plugs – finished!

### 11.1.1 Individual configurations

#### SOCKET COMBINATIONS



For a pure socket combination you decide, ...



... whether all sockets are supplied via one supply line, ...



... whether an outgoing line is required in addition to the incoming line ...



... or even whether a combination of both cases is required (optional).

**STEP 1: SELECT SIZE**

plug + go is available in four different sizes. Choose between a simple flush-mounted box or a multiple installation with up to four units. If an empty cavity wall box is planned, special devices such as data connections can be added later.

**STEP 2: DETERMINE FORMAT**

plug + go is variable in all areas. Install the plug-in system both in horizontal and vertical formats. In this way you implement the electrical installation in an optimal manner, always aligned to the property, and the arrangement of the inserts also remains flexible.

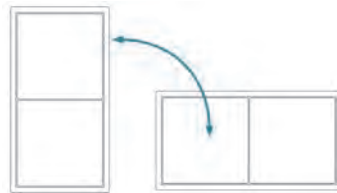
**STEP 3: SELECT INSERTS**

Thanks to the JUNG modular system, plug + go can be individually populated with various inserts. Changeover and 2-gang switches, SCHUKO® sockets, dimmers or USB chargers are quickly installed. You decide which technology is installed at which position. plug + go is flexible.

**STEP 4: SELECT COVERS**

All solutions are, of course, available in the variety of JUNG designs. They can thus be ideally matched to the interior design in various materials, shapes and colours. Simply specify the appropriate covers in the required design in the ordering process.



### 11.1.2 The potential savings

Modular components make work on the building site easier. Industrial prefabrication is the solution for more cost-efficient projects. The savings potential of plug + go is enormous.

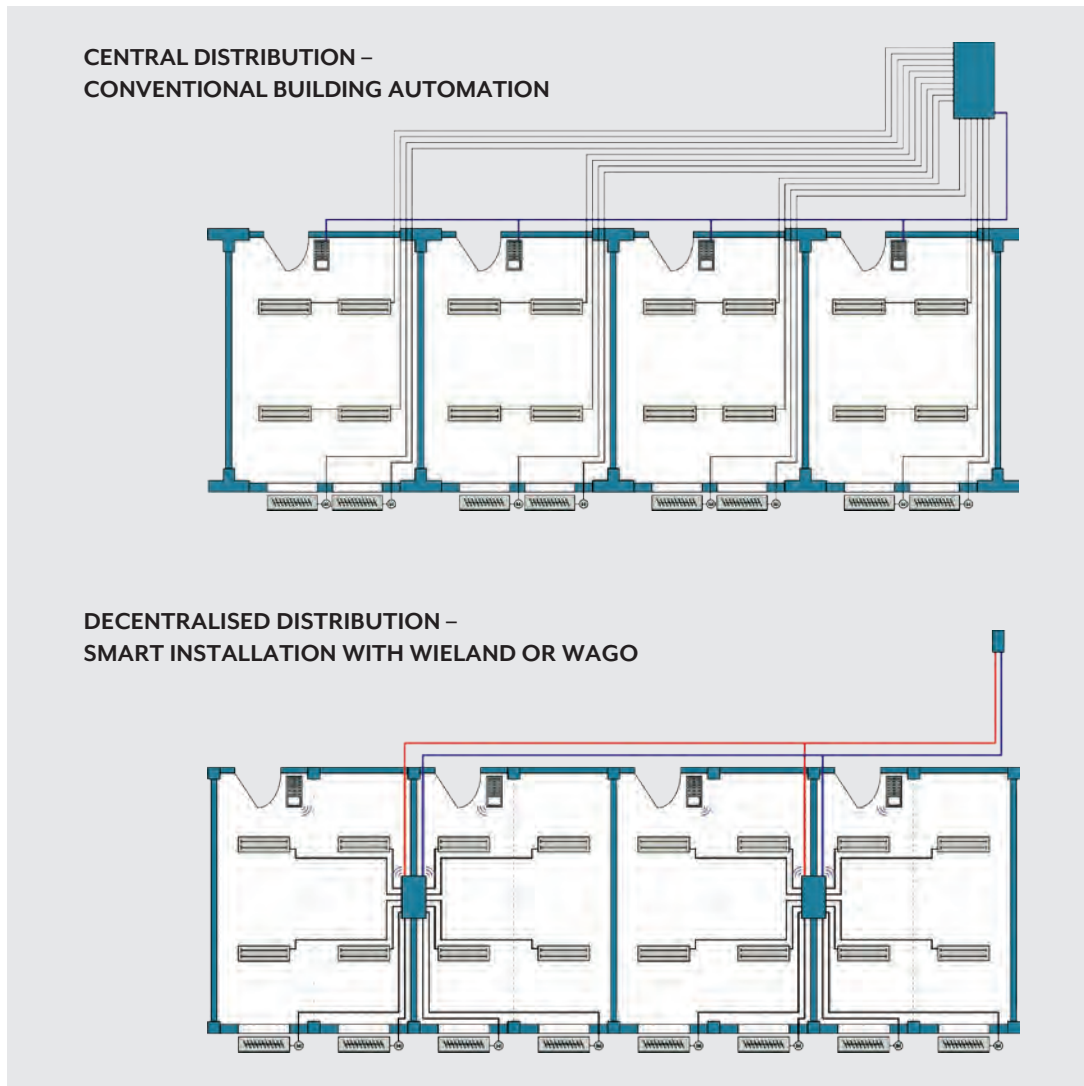

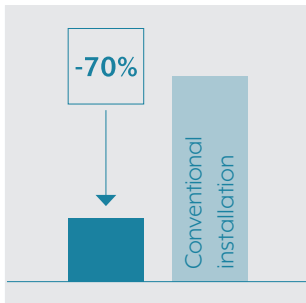

#### Low time requirement

The cabling time is minimal. The installation time at the building site is noticeably reduced.

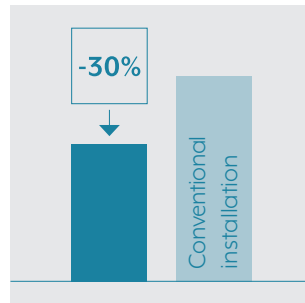

#### Low total costs

Rapid installation, high quality, low defect frequency: The total costs reduce by up to 30%.

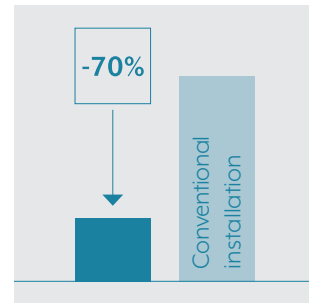

#### Shorter cable lengths

The cables are simply connected. Multiple junction boxes are likewise unnecessary.

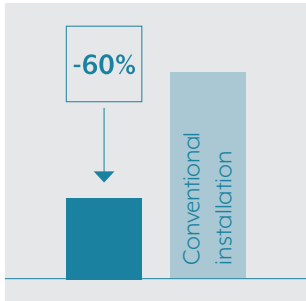

#### Reduced fire load

Direct plug-in distribution blocks reduce the fire load by up to 60%. A clear plus in safety

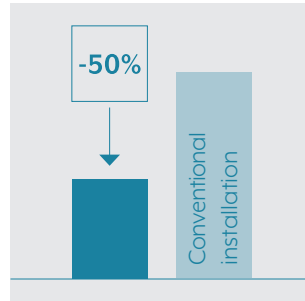

#### Low volume of copper

The total amount of copper is around half compared to conventional installations.

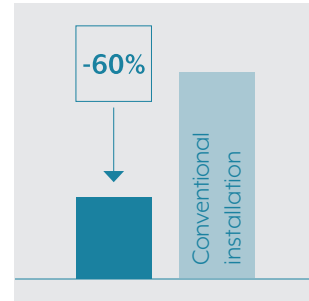

#### Smaller equipment rooms

Less material thanks to intelligent cable management: Equipment rooms need less space.

The secret of plug + go: plug instead of screw! This reduces the installation time on the building site and the overall costs are significantly lower than for conventional approaches.

While the defect frequency on the building site reduces, the quality of the work increases. Once planned, the installation is then quickly completed. Serial and modular building in the electrical trade is the solution for projects in which rooms are frequently repeated.

### 11.1.3 Use in the hotel sector



© BEYOND by Geisel, Munich

#### **INFRASTRUCTURE CABLING**

The supply for hotel rooms is provided using a flexible bus bar with large-diameter wires. This ensures clear structures at the installation level of the corridor area.

#### **DECENTRALISED ROOM AUTOMATION**

The modular, decentralised and direct plug-in systems can be quickly and easily expanded or adapted to meet changing usage conditions.

#### **SUN PROTECTION**

The decentralised control or automation of the sun protection actuators provides a very large savings potential, as fewer cables have to be installed.

#### **LIGHTING (CONTROLLED)**

Due to the comprehensive provision of the rooms with mains and DALI signals, changes or extensions can be realised without effort.



## 12. INNOVATION: PLUG & LIGHT

### 12.1 PLUG & LIGHT: THE FUNCTIONALLY RELIABLE LIGHTING DESIGN 240

12.1.1 Rethinking light	241
12.1.2 Advantages of Plug & Light.	241
12.1.3 Plug-in lighting moods	242
12.1.4 The light socket	244
12.1.5 The LED spotlights	246
12.1.6 The LED floodlights	248
12.1.7 The range of frames	250

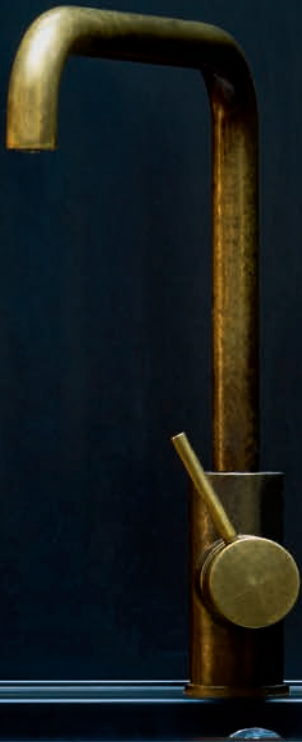

## 12. Innovation: Plug & Light

Plug-in operating equipment and plug-in installation materials optimise the installation time. Large construction or modernisation projects in particular benefit from the time saved by installing prefabricated modules.

### 12.1 Plug & Light: the functionally reliable lighting design

Particularly for use in hotels, Plug & Light always ensures the optimum lighting situation. With this system, switch and lighting design come from a single source and can therefore be specifically matched to the interior.

Plug & Light is the first light socket that provides maximum flexibility in planning. For functionally reliable lighting design to match the switch design, because Plug & Light fits into any commercially available European wall box. Only the position of the sockets and switches for the future light sources need to be planned during the building process.

The appropriate design and the desired light attachments can be selected at the end or after completion – the use of new Plug & Light lamps is possible at any time. The appropriate LED light attachments dock onto the light socket using magnets. The ceiling spotlight on the wall of a hotel room becomes a reading lamp in the evening hours when turned to the appropriate position. The LED floodlight, which expertly sets the scene for a picture during the day, becomes - rotated by 180° - discreet orientation lighting in the dark (see chapter “8.9 Plug & Light as pilot lights” on page 157).

The 12 V low voltage makes the system childproof, and dismounting protection is also available.

JUNG provides frames and covers for Plug & Light in the A and LS ranges.



### 12.1.1 Rethinking light

The requirements for lighting change where living and working spaces converge. The innovative Plug & Light system is perfect for this. It can always be modularly adapted to the respective challenge. Just as you like and without assembly effort.

#### THE FEATURES

The appropriate LED light attachments dock onto the light socket using magnets. The light can be dimmed immediately without flickering. From light to dark to Dim to Warm, which resembles the dimming behaviour of an incandescent lamp. Once inserted into the light socket, the attachment can be rotated 360° without any stops and can even be replaced during operation.

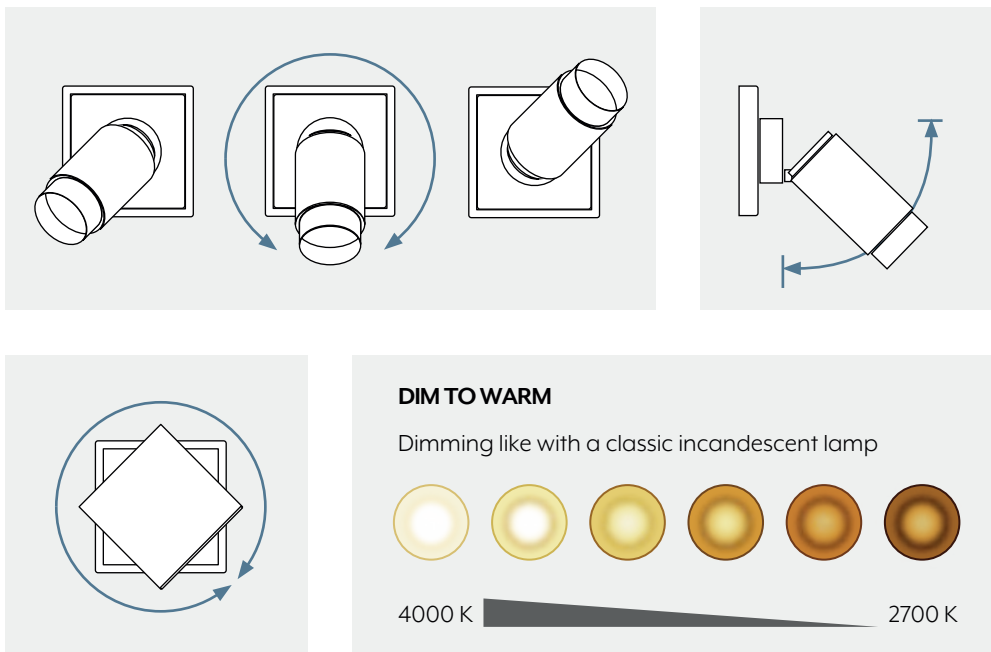

### 12.1.2 Advantages of Plug & Light

#### PLUG & LIGHT IS FUNCTIONALLY RELIABLE BECAUSE

- the tested combination of luminaire and dimmer ensures reliable control.
- it is an established defined interface: All components are clearly defined, so that each combination of insert and attachment results in a useful function.
- the system is nevertheless safe in the event of contact thanks to 12 V low-voltage.

#### PLUG & LIGHT IS ECONOMICALLY ATTRACTIVE BECAUSE

- it is an innovative system that upgrades a property. By simply replacing the light attachments, any furnishing style can be realised – contemporary and adaptable to any space requirement.
- the latest energy-saving LED technology has been taken into account.
- simple luminaire replacement is possible without intervention in the electrical installation.
- the installation costs are low thanks to the simplicity of the system.

#### CROSS-SYSTEM

Plug & Light is an innovative system that can be combined with both conventional electrical installations and modern building system technology. For maximum comfort and future-oriented, individually usable solutions.

### 12.1.3 Plug-in lighting moods

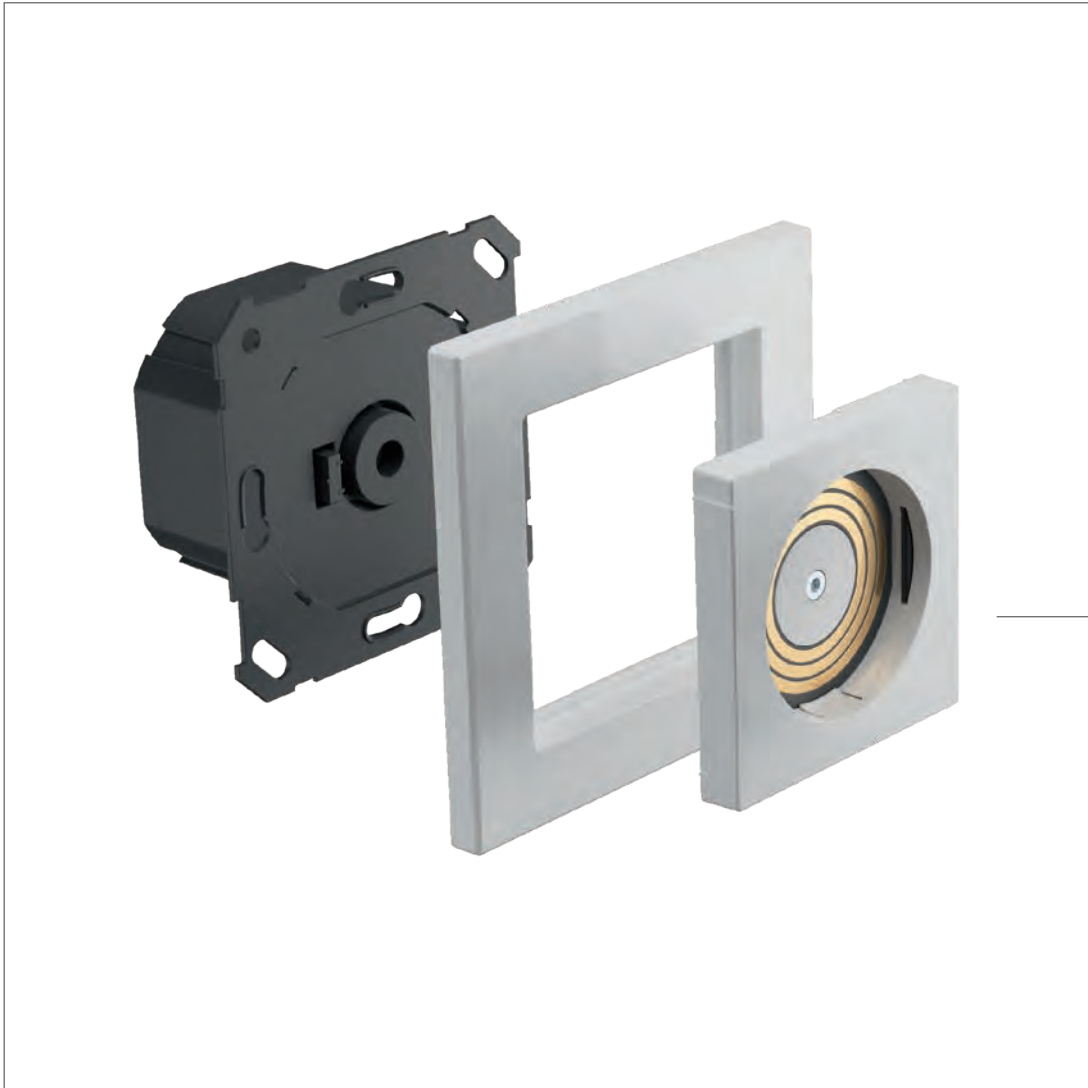

The Plug & Light system is designed as a modular system. It consists of a flush-mounted insert with the electronics, a frame, the light socket and a light attachment. The flush-mounted insert is mounted in a wall box according to DIN 49073. JUNG provides compatible frames and covers for Plug & Light. The switch ranges A 550, A creation, A flow, LS 990, LS design, LS plus and LS ZERO perfectly match the modern LED system.

The light attachment is held in place on the light socket by a strong magnet. Three gold-plated sliding contacts provide the necessary electrical connection. In addition to the power supply, the sliding contacts together with the attachment and light socket regulate the dimming process.

## LIGHT ATTACHMENTS

### PLUG & LIGHT LED SPOTLIGHTS

In addition to the light socket, Insta has developed two LED light attachments that JUNG provides to match its switch designs. The Plug & Light spotlight has three-stage adjustable glare protection and can create the appropriate lighting mood on ceilings and walls.



### PLUG & LIGHT LED FLOODLIGHTS

The design of the Plug & Light floodlight is reminiscent of a classic switch. With glare-free optics, it sets accent lighting or is used as work light. An insert as discreet orientation light is also possible. The light attachments from Insta guarantee optimum light distribution over the entire dimming range and can be rotated 360° without any stops.



## AN OPEN NETWORK

### PLUG & LIGHT LIGHTING RANGES

Brumberg was the first luminaire manufacturer to introduce five suitable lighting ranges for Plug & Light. They each consist of pendant, ceiling and wall luminaires that can be combined with the light socket in the JUNG switch design. Other manufacturers are invited to use the system to design their own luminaires.



### 12.1.4 The light socket

The light socket is the core of the innovative lighting technology. It consists of a Plug & Light flush-mounted insert with power supply and control electronics. The flush-mounted insert is mounted in a wall box according to DIN 49073.



black



white

**POWER SUPPLY PLUG & LIGHT**

DESCRIPTION	REFERENCE	REF. NO.
<ul style="list-style-type: none"> <li>▪ Ballast for the switching and dimming of light attachments from the Plug &amp; Light system</li> <li>▪ Automatic detection of the inserted light attachments</li> <li>▪ Safe extra-low voltage SELV DC</li> <li>▪ Mounting in wall box according to DIN 49073</li> </ul>	Power supply P & L	PL 08 U
<p>→ Connection to switches, switch inserts with relay contact, electronic switch inserts (trailing edge phase control principle, ref. no.: 1704 ESE), 2-wire LED dimmer (trailing edge phase control principle) and 3-wire LED dimmer (trailing edge phase control principle)</p> <p>→ Compatible dimmers: 1224 LED UDE, 1710 DE, 1711 DE, 1730 DD, 1731 DD, 1724 DM, UD 1755 REG, ULZ 1755 REG, FM UD 420250 REG, FM UD 5500 REG, FM UD 20250 UP, 3901 REGHE, 3902 REGHE, 3904 REGHE</p>		

**COVER**
**A RANGE**

DESCRIPTION	COLOUR	REF. NO.
<ul style="list-style-type: none"> <li>▪ Magnetic fixing of the light attachments</li> <li>▪ Mechanical locking of the light attachments for ceiling mounting and as dismounting protection</li> <li>▪ Electrical coupling using gold-plated sliding contacts</li> </ul>	white	PL A DMS WW
	black	PL A DMS SW
	aluminium *	PL A DMS AL
	* Lacquered metal versions	

**LS RANGE**

DESCRIPTION	COLOUR	REF. NO.
<ul style="list-style-type: none"> <li>▪ Magnetic fixing of the light attachments</li> <li>▪ Mechanical locking of the light attachments for ceiling mounting and as dismounting protection</li> <li>▪ Electrical coupling using gold-plated sliding contacts</li> </ul>	white	PL LS DMS WW
	black	PL LS DMS SW
	aluminium *	PL AL DMS-L
	stainless steel	PL ES DMS-L
* Lacquered metal versions		

**RELEASE MAGNET**

DESCRIPTION	REFERENCE	REF. NO.
<ul style="list-style-type: none"> <li>▪ for removal of the luminaires</li> </ul>	Release magnet	PL MAGNET 01

### 12.1.5 The LED spotlights

The spotlight is a Plug & Light light attachment. With the mechanical joint and the available rotatability over the base, it is suitable for numerous applications.



**PLUG & LIGHT LED SPOTLIGHT**

**DESCRIPTION**

- Light attachment for indoor lighting
- Mounting on wall or ceiling by attachment to the light socket of the Plug & Light system
- Dimming with appropriate LED dimmer with constant colour temperature of 2700 K
- Symmetrical optics, 35° beam angle
- Flicker-free light over the entire dimming range
- Light attachment can be changed during operation
- Adjustable anti-glare ring via 3 locking steps (5, 10 and 15 mm)
- Can be swivelled by 90°
- Continuously rotatable by 360°

**COLOUR**

white  
white – black  
black  
aluminium – black

**REF. NO.**

PL SI D05 WW  
PL SI D05 WW SW  
PL SI D05 SW SW  
PL SI D05 AL SW

**PLUG & LIGHT LED SPOTLIGHT (DIM TO WARM)**

**DESCRIPTION**

- Light attachment for indoor lighting
- Mounting on wall or ceiling by attachment to the light socket of the Plug & Light system
- Changing of the colour temperature between 2700 K and 4000 K with simultaneous brightness increase from minimum to maximum, with suitable LED dimmer
- Symmetrical optics, 35° beam angle
- Flicker-free light over the entire dimming range
- Light attachment can be changed during operation
- Adjustable anti-glare ring via 3 locking steps (5, 10 and 15 mm)
- Can be swivelled by 90°
- Continuously rotatable by 360°

**COLOUR**

white  
black  
black  
aluminium – black

**REF. NO.**

PL SI WD05 WW  
PL SI WD05 WW SW  
PL SI WD05 SW SW  
PL SI WD05 AL SW

### 12.1.6 The LED floodlights

The floodlight is a Plug & Light light attachment. The asymmetrical light distribution ensures diffuse light. Due to the special feature of being rotatable, the floodlight generates indirect lighting, e.g. directed upwards.





**PLUG & LIGHT LED FLOODLIGHT**

DESCRIPTION	COLOUR	REF. NO.
<ul style="list-style-type: none"> <li>▪ Light attachment for indoor lighting</li> <li>▪ Mounting by attachment to the light socket of the Plug &amp; Light system</li> <li>▪ Accent light or work light</li> <li>▪ Dimming with appropriate LED dimmer with constant colour temperature of 2700 K</li> <li>▪ Glare-free asymmetrical optics</li> <li>▪ Flicker-free light over the entire dimming range</li> <li>▪ Light attachment can be changed during operation</li> <li>▪ Continuously rotatable by 360°</li> </ul>	white	PL FI D05 WW
	black	PL FI D05 SW
	aluminium*	PL FI D05 AL-L
	stainless steel*	PL FI D05 ES-L
	* Lacquered metal versions	

**PLUG & LIGHT LED FLOODLIGHT (DIM TO WARM)**

DESCRIPTION	COLOUR	REF. NO.
<ul style="list-style-type: none"> <li>▪ Light attachment for indoor lighting</li> <li>▪ Mounting by attachment to the light socket of the Plug &amp; Light system</li> <li>▪ Accent light or work light</li> <li>▪ Changing of the colour temperature between 2700 K and 4000 K with simultaneous brightness increase from minimum to maximum, with suitable LED dimmer</li> <li>▪ Glare-free asymmetrical optics</li> <li>▪ Flicker-free light over the entire dimming range</li> <li>▪ Light attachment can be changed during operation</li> <li>▪ Continuously rotatable by 360°</li> </ul>	white	PL FI WD05 WW
	black	PL FI WD05 SW
	aluminium*	PL FI WD05 AL-L
	stainless steel*	PL FI WD05 ES-L
	* Lacquered metal versions	

### 12.1.7 The range of frames

For a first impression of the wide range of frames in the JUNG design, we are showing here a small selection of the LS and A ranges. With many other frame colours, JUNG provides an extensive range for every interior.



## FRAMES FOR THE LS 990 RANGE

## PLASTIC FRAMES

	COLOUR	MATERIAL	FRAME	REF. NO.
	white	Duroplastic (scratch-proof), glossy	1-gang 81 x 81 mm	LS 981 WW
			2-gang 81 x 152 mm	LS 982 WW
			3-gang 81 x 223 mm	LS 983 WW
			4-gang 81 x 294 mm	LS 984 WW
			5-gang 81 x 365 mm	LS 985 WW

	COLOUR	MATERIAL	FRAME	REF. NO.
	black	Duroplastic (scratch-proof), glossy	1-gang 81 x 81 mm	LS 981 SW
			2-gang 81 x 152 mm	LS 982 SW
			3-gang 81 x 223 mm	LS 983 SW
			4-gang 81 x 294 mm	LS 984 SW
			5-gang 81 x 365 mm	LS 985 SW

Further frame colours from the LS 990 range can be found at [www.jung.de](http://www.jung.de).

## METAL FRAMES

	COLOUR	MATERIAL	FRAME	REF. NO.
	aluminium	Metal version	1-gang 81 x 81 mm	AL 2981
			2-gang 81 x 152 mm	AL 2982
			3-gang 81 x 223 mm	AL 2983
			4-gang 81 x 294 mm	AL 2984
			5-gang 81 x 365 mm	AL 2985

	COLOUR	MATERIAL	FRAME	REF. NO.
	stainless steel	Metal version	1-gang 81 x 81 mm	ES 2981
			2-gang 81 x 152 mm	ES 2982
			3-gang 81 x 223 mm	ES 2983
			4-gang 81 x 294 mm	ES 2984
			5-gang 81 x 365 mm	ES 2985



	COLOUR	MATERIAL	FRAME	REF. NO.
	chrome	Metal version	1-gang 81 x 81 mm	GCR 2981
			2-gang 81 x 152 mm	GCR 2982
			3-gang 81 x 223 mm	GCR 2983
			4-gang 81 x 294 mm	GCR 2984
			5-gang 81 x 365 mm	GCR 2985

	COLOUR	MATERIAL	FRAME	REF. NO.
	Classic brass	Metal version	1-gang 81 x 81 mm	ME 2981 C
			2-gang 81 x 152 mm	ME 2982 C
			3-gang 81 x 223 mm	ME 2983 C
			4-gang 81 x 294 mm	ME 2984 C
			5-gang 81 x 365 mm	ME 2985 C



Further frame colours from the LS 990 range can be found at [www.jung.de](http://www.jung.de).

## FRAMES FOR THE A CREATION RANGE

## A CREATION IN PLASTIC

	COLOUR	MATERIAL	FRAME	REF. NO.
	white 	Thermoplastic (breakproof) high-gloss	1-gang 87 x 87 mm	AC 581 BF WW
			2-gang 87 x 158 mm	AC 582 BF WW
			3-gang 87 x 229 mm	AC 583 BF WW
			4-gang 87 x 300 mm	AC 584 BF WW
			5-gang 87 x 371 mm	AC 585 BF WW

 Laser engraving possible

	COLOUR	MATERIAL	FRAME	REF. NO.
	black 	Thermoplastic (breakproof) high-gloss	1-gang 87 x 87 mm	AC 581 BF SW
			2-gang 87 x 158 mm	AC 582 BF SW
			3-gang 87 x 229 mm	AC 583 BF SW
			4-gang 87 x 300 mm	AC 584 BF SW
			5-gang 87 x 371 mm	AC 585 BF SW

 Laser engraving possible

	COLOUR	MATERIAL	FRAME	REF. NO.
	aluminium	Duroplastic, lacquered	1-gang 84 x 84 mm	AC 581 AL
			2-gang 84 x 155 mm	AC 582 AL
			3-gang 84 x 226 mm	AC 583 AL
			4-gang 84 x 297 mm	AC 584 AL
			5-gang 84 x 368 mm	AC 585 AL

Further frame colours from the A CREATION range can be found at [www.jung.de](http://www.jung.de).

## A CREATION IN GLASS

	COLOUR	MATERIAL	FRAME	REF. NO.
	white	Glass	1-gang 84 x 84 mm	AC 581 GL WW
			2-gang 84 x 155 mm	AC 582 GL WW
			3-gang 84 x 226 mm	AC 583 GL WW
			4-gang 84 x 297 mm	AC 584 GL WW
			5-gang 84 x 368 mm	AC 585 GL WW

	COLOUR	MATERIAL	FRAME	REF. NO.
	black	Glass	1-gang 84 x 84 mm	AC 581 GL SW
			2-gang 84 x 155 mm	AC 582 GL SW
			3-gang 84 x 226 mm	AC 583 GL SW
			4-gang 84 x 297 mm	AC 584 GL SW
			5-gang 84 x 368 mm	AC 585 GL SW

	COLOUR	MATERIAL	FRAME	REF. NO.
	silver (mirror finish)	Glass	1-gang 84 x 84 mm	AC 581 GL SI
			2-gang 84 x 155 mm	AC 582 GL SI
			3-gang 84 x 226 mm	AC 583 GL SI
			4-gang 84 x 297 mm	AC 584 GL SI
			5-gang 84 x 368 mm	AC 585 GL SI

Further frame colours from the A Creation range can be found at [www.jung.de](http://www.jung.de).

## FRAMES FOR THE A FLOW RANGE

## A FLOW IN PLASTIC

	COLOUR	MATERIAL	FRAME	REF. NO.
	white <b>L</b>	Thermoplastic (breakproof) high-gloss	1-gang 85 x 85 mm	AF 581 BF WW
			2-gang 85 x 156 mm	AF 582 BF WW
			3-gang 85 x 227 mm	AF 583 BF WW
			4-gang 85 x 298 mm	AF 584 BF WW
			5-gang 85 x 369 mm	AF 585 BF WW

**L** Laser engraving possible

	COLOUR	MATERIAL	FRAME	REF. NO.
	black <b>L</b>	Thermoplastic (breakproof) high-gloss	1-gang 85 x 85 mm	AF 581 BF SW
			2-gang 85 x 156 mm	AF 582 BF SW
			3-gang 85 x 227 mm	AF 583 BF SW
			4-gang 85 x 298 mm	AF 584 BF SW
			5-gang 85 x 369 mm	AF 585 BF SW

**L** Laser engraving possible

	COLOUR	MATERIAL	FRAME	REF. NO.
	aluminium <b>L P</b>	Thermoplastic (breakproof) lacquered	1-gang 85 x 85 mm	AF 581 BF AL
			2-gang 85 x 156 mm	AF 582 BF AL
			3-gang 85 x 227 mm	AF 583 BF AL
			4-gang 85 x 298 mm	AF 584 BF AL
			5-gang 85 x 369 mm	AF 585 BF AL

**L** Laser engraving possible

**P** Colour printing possible

Further frame colours from the A Flow range can be found at [www.jung.de](http://www.jung.de).

## A 550 IN PLASTIC

	COLOUR	MATERIAL	FRAME	REF. NO.
	white <b>L</b>	Thermoplastic (breakproof) high-gloss	1-gang 85 x 85 mm	A 5581 BF WW
			2-gang 85 x 156 mm	A 5582 BF WW
			3-gang 85 x 227 mm	A 5583 BF WW
			4-gang 85 x 298 mm	A 5584 BF WW
			5-gang 85 x 369 mm	A 5585 BF WW

**L** Laser engraving possible

	COLOUR	MATERIAL	FRAME	REF. NO.
	black <b>L</b>	Thermoplastic (breakproof) high-gloss	1-gang 85 x 85 mm	A 5581 BF SW
			2-gang 85 x 156 mm	A 5582 BF SW
			3-gang 85 x 227 mm	A 5583 BF SW
			4-gang 85 x 298 mm	A 5584 BF SW
			5-gang 85 x 369 mm	A 5585 BF SW

**L** Laser engraving possible

	COLOUR	MATERIAL	FRAME	REF. NO.
	aluminium <b>L P</b>	Thermoplastic (breakproof) lacquered	1-gang 85 x 85 mm	A 5581 BF AL
			2-gang 85 x 156 mm	A 5582 BF AL
			3-gang 85 x 227 mm	A 5583 BF AL
			4-gang 85 x 298 mm	A 5584 BF AL
			5-gang 85 x 369 mm	A 5585 BF AL

**L** Laser engraving possible

**P** Colour printing possible

Further frame colours from the A 550 range can be found at [www.jung.de](http://www.jung.de).



**13. DOOR COMMUNICATION AND ACCESS CONTROL****13.1 DEVICE OVERVIEW 257****13.2 DOOR COMMUNICATION 258**

13.2.1 Diversity of design in door communication 259

---

13.2.2 Video indoor stations 259

---

13.2.3 Audio indoor station 262

---

13.2.4 Connection of video and audio indoor unit 264

---

13.2.5 Standard audio indoor station and standard design 265

---

13.2.6 Connection of standard and universal audio indoor unit 267

---

**13.3 DOOR COMMUNICATION AND KNX 268****13.4 OVERSIZE ROCKER 269**

13.4.1 Installation special features 270

---

13.4.2 Installation 270

---

# 13. Door communication and access control

The entrance area of an hotel does not only mean welcoming the guests pleasantly. Particular technical requirements must also be met. These can be reliably realised with strong partners.





## 13.1 Device Overview

<b>VIDEO INDOOR STATION</b>	<b>RANGE</b>	<b>REFERENCE NUMBER</b>
Video indoor station 2.2"	A, AS	SI VI A 622...
Video indoor station 2.7"	CD	SI VI CD 627...
Video indoor station 2.7"	LS	SI VI LS 627

<b>AUDIO INDOOR STATION</b>	<b>RANGE</b>	<b>REFERENCE NUMBER</b>
Audio indoor station	A, AS	SI AI A 6...
Audio indoor station	CD	SI AI CD
Audio indoor station	LS	SI AI LS 6
Standard audio indoor station	A	SI 4 A...
Standard audio indoor station Design	A	SI 4 AD...

<b>OVERSIZE ROCKER</b>	<b>REFERENCE NUMBER</b>
Oversize rocker (70 x 212.4 mm)	ES 2993...

## 13.2 Door communication

The elegant video and audio indoor stations in the JUNG design are impressive with their variety of design and function. Technically, they are perfectly compatible with Siedle door stations.

The advantages: easy operation and a new variety of possibilities.

The JUNG indoor stations fit in harmoniously with the rest of the electrical installation in the overall design.

### 13.2.1 Diversity of design in door communication

In surface-mounted or flush-mounted installation, the new indoor stations from JUNG in switch design appeal with their form, technology and uniform operation.

The JUNG modular system gives you design freedom in the selection and installation of the indoor stations. Vertically or horizontally, in multiple frames or separately from each other, the new modular system enables installation as desired.

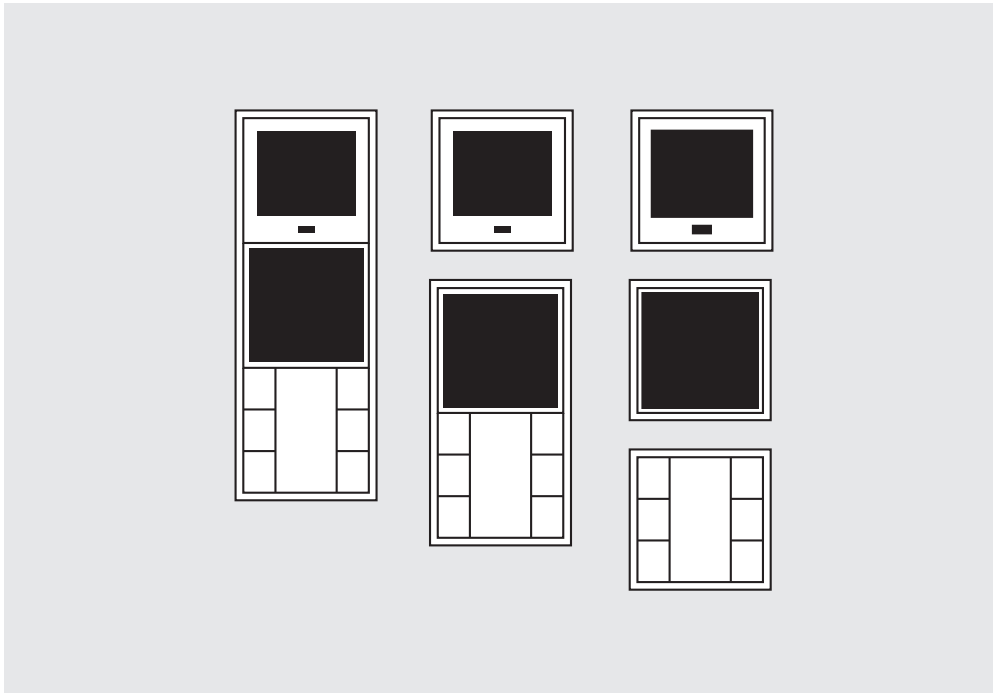

The indoor station modules can be combined with multiple frames **1** (horizontally or vertically). Offset mounting in separate frames **2+3** as well as mounting in surface caps is possible.

### 13.2.2 Video indoor stations

High functionality and easy operation: these are what the new JUNG video indoor stations stand for. You can see who is in front of the door at a glance. This is ensured by the large TFT colour monitor with a screen diagonal of 2.2" or 2.7". By setting the brightness and colour, the picture can be ideally adapted to the light conditions. In the day or evening – anyone who asks for admittance can be clearly identified. The high quality loudspeaker with adjustable voice volume and good sound quality ensures optimal communication at the door.

The video indoor stations consist of 3 modules: TFT screen, audio module and push-button module (Standard or Universal). The indoor station modules can be combined with multiple frames (horizontally or vertically). Offset mounting in separate frames as well as mounting in surface caps is possible. An additional power supply is necessary for the operation of the video indoor station. Recommendation: VNG 602 from Siedle (see Siedle planning manual).

## Video indoor station 2.2"

## A / AS RANGE



MATERIAL	COLOUR	REF. NO.
Thermoplastic (breakproof) high-gloss	ivory	SI VI A 622 W
	white	SI VI A 622 WW
	black	SI VI A 622 SW



MATERIAL	COLOUR	REF. NO.
Thermoplastic (breakproof) lacquered	aluminium	SI VI A 622 AL
	champagne	SI VI A 622 CH
	mocha	SI VI A 622 MO
	matt anthracite	SI VI A 622 ANM

## Video indoor station 2.7"

## CD RANGE



MATERIAL	COLOUR	REF. NO.
Thermoplastic (breakproof) high-gloss	ivory	SI VI CD 627 W
	white	SI VI CD 627 WW

## LS RANGE



MATERIAL	COLOUR	REF. NO.
Thermoplastic (breakproof) high-gloss	ivory	SI VI LS 627 W
	white	SI VI LS 627 WW
	light grey	SI VI LS 627 LG
	black	SI VI LS 627 SW

MATERIAL	COLOUR	REF. NO.
Metal versions (* lacquered aluminium)	aluminium	SI VI AL 627
	stainless steel	SI VI ES 627
	anthracite *	SI VI AL 627 AN
	dark *	SI VI AL 627 D

**Overview of the functions;**

- Screen diagonal 55 mm (2.2") for the A range and 70 mm (2.7") for the CD ranges
- 320 x 240 pixels
- Adjustment for brightness and colour
- Including video connection cable (black, 220 mm)
- Calling, speech, see, door release, light, storey call, switch/control functions and internal communication
- Reverse polarity protected 2-wire installation; additional power supply required (J-Y(St)Y 2 x 2 x 0.8)
- Automatic video connection during door call
- Speech button with green status LED
- Light, call silencing, monitor and function button freely configurable. Function of buttons can be triggered without additional installation, e.g. for internal telephony, triggering of switching/control functions in combination with Siedle bus switching module BSM/BSE 650-..., targeted selection of door loudspeakers (outdoor stations)/cameras
- A switch function (in connection with the Siedle BSM/BSE 650-.. bus switch module) can be configured on the door release button by BPS.
- Integrated audio and video privacy
- Parallel connection (simultaneous calling) of max. 16 video indoor stations (from the 3rd device onwards, the Siedle bus programming software (BPS) is required for programming).
- audio/video connection possible at any time, even without a subsequent door call
- High-quality sound and great loudspeaker dynamics
- Electret capacitor microphone
- Connection for Siedle In-Home bus
- Connection for storey call button
- Call generator with 11 ring tone melodies, including gong
- Ring tone volume can be set at 5 levels up to 92 dB(A)
- Voice volume can be set at 5 levels
- Programming manually, plug and play and using Siedle bus programming software (BPS) according to Siedle system manual
- Indoor station with hands-free operation
- Status display for active speech connection
- Call silencing with status display
- Call differentiation between storey call, 2 door calls and internal call
- Door release/light functions at any time via the bus line
- Door call pickup
- Group formation for door calls. Each indoor station can belong to up to 4 groups on the same line
- Intercom functions:
  - Call forwarding
  - Internal group call
  - Collective announcement
  - Automatic call pickup for internal call
  - Doormatic
- Connection for additional power supply (necessary for operation of a video module, lighting of the labelling area in the universal push-button module and for connection of a second push-button module.)

### 13.2.3 Audio indoor station

The audio indoor stations provide a wide range of functions and convenience. The condenser microphone ensures brilliant audio transmission. Functions such as call forwarding or internal call support easy communication within the house.

The integrated audio privacy function and the speech button with status LED ensure easy operation. Clear symbols on the labelling area or the optional design cover ensure orientation and assignment of the push-buttons. In addition to the occupied fields, two favourite buttons can be programmed with further functions.

The video indoor stations consist of 2 modules: Audio module and push-button module (Standard or Universal). The indoor station modules can be combined with multiple frames (horizontally or vertically). Offset mounting in separate frames as well as mounting in surface caps is possible.

#### Audio indoor station

##### A RANGE



MATERIAL	COLOUR	REF. NO.
Thermoplastic (breakproof) high-gloss	ivory	SI AI A 6 W
	white	SI AI A 6 WW
	black	SI AI A 6 SW

MATERIAL	COLOUR	REF. NO.
Thermoplastic (breakproof) lacquered	aluminium	SI AI A 6 AL
	champagne	SI AI A 6 CH
	mocha	SI AI A 6 MO
	matt anthracite	SI AI A 6 ANM

##### CD RANGE



MATERIAL	COLOUR	REF. NO.
Thermoplastic (breakproof) high-gloss	ivory	SI AI CD 6 W
	white	SI AI CD 6 WW

##### LS RANGE



MATERIAL	COLOUR	REF. NO.
Thermoplastic (breakproof) high-gloss	ivory	SI AI LS 6 W
	white	SI AI LS 6 WW
	light grey	SI AI LS 6 LG
	black	SI AI LS 6 SW

MATERIAL	COLOUR	REF. NO.
Metal versions (* lacquered aluminium)	aluminium	SI AI AL 6
	stainless steel	SI AI ES 6
	anthracite *	SI AI AL 6 AN
	dark *	SI AI AL 6 D

**Overview of the functions;**

- Calling, speech, door release, light, storey call, switch/control functions and internal communication
- Reverse polarity protected 2-wire installation (J-Y(St)Y 2 x 2 x 0.8)
- Speech button with green status LED
- Light, call silencing and the two function buttons are freely configurable. Function of buttons can be triggered without additional installation, e.g. for internal telephony, triggering of switching/control functions in combination with Siedle bus switching module BSM/BSE 650-..., targeted selection of door loudspeakers (outdoor stations)
- A switch function (in connection with the Siedle BSM/BSE 650-.. bus switch module) can be configured on the door release button by BPS.
- Integrated audio privacy function
- Parallel connection (simultaneous calling) of max. 4 audio modules or audio indoor stations (from the 3rd device onwards, the Siedle bus programming software (BPS) is required for programming).
- Speech connection possible at any time, even without any door call
- High-quality sound and great loudspeaker dynamics
- Electret capacitor microphone
- Connection for Siedle In-Home bus
- Connection for storey call button
- Call generator with 11 ring tone melodies, including gong
- Ring tone volume can be set at 5 levels up to 92 dB(A)
- Voice volume can be set at 5 levels
- Programming manually, plug and play and using Siedle bus programming software (BPS) according to Siedle system manual
- Indoor station with hands-free operation
- Status display for active speech connection
- Call silencing with status display
- Call differentiation between storey call, 2 door calls and internal call
- Door release/light functions at any time via the bus line
- Door call pickup
- Group formation for door calls. Each indoor station can belong to up to 4 groups on the same line
- Intercom functions:
  - Call forwarding
  - Internal group call
  - Automatic call pickup for internal call
  - Doormatic
- 5 LEDs for display (e.g. door open) without additional cabling
- Display of operating status using an LED
- Visible call display with flashing LED at the speech button
- Labelling area
- Including labelling foils with symbols for audio and video
- Including audio connection cable (red, 220 mm)

### 13.2.4 Connection of video and audio indoor unit

The recommended mounting height is 1.50 m. Each module is installed in a flush wall box according to DIN 49073. Installation in a deep box is recommended. Mounting is done with the enclosed support rings.

- They can be mounted in combination or individually - horizontally or vertically.
- The modules are combined with the frames from the AS, A, CD or LS ranges.
- The modules are connected to each other using the supplied connection cables.
- The connection to the Siedle In-Home bus (if necessary, additional power supply + storey call button) is made at the audio module. An additional power supply is connected to the Universal push-button module. Here, the two audio connection sockets can be interchanged as desired.
- For remote mounting, 700 mm long connection cables are required.

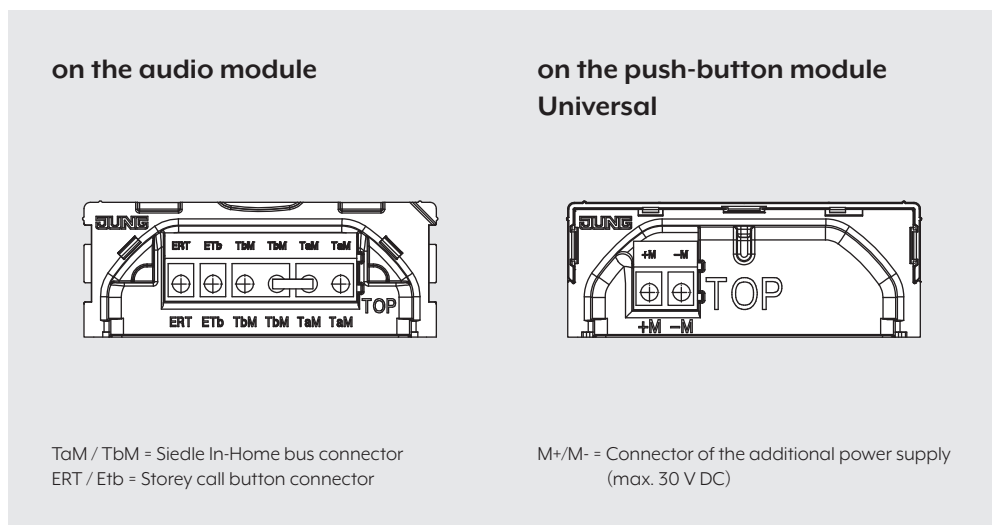

Cable type: Communication cable J-Y (St) Y with twisted pairs.

The usual diameter is 0.6 mm or 0.8 mm.

1. Remove the plug-in screw terminal.
2. Connect the cables according to the labelling (TaM/TbM).
3. A storey call button must be connected between the terminals ERT and ETb.
4. Put the screw terminal back into the provided guide.  
Make sure that the terminals are correctly seated.
5. A terminating resistor is connected between TaM and TbM. This terminating resistor is required if the modular indoor station is the last device in a video line. If you loop the bus through the modular indoor station, this terminating resistor must always be removed.
6. Installation, commissioning and programming are described in the Siedle system manual (included with the bus power supply units BNG/BVNG 650-...).



### 13.2.5 Standard audio indoor station and standard design

The appeal of the standard audio indoor stations for surface mounting is in their compact structure. In the A range design, installation is possible with or without freely selectable design frames. Hands-free operation ensures pleasant conversation without handset and without cables. The installation can be ideally adapted to suit personal needs with a voice volume that can be set at five different levels. There are eleven ring tones to choose from. Large buttons with clear symbols enable safe operation. Light and mute button can be freely configured and the door release button can also be assigned with a switching function. Restrained elegance and clear purism are the hallmarks of the Standard audio indoor station.

#### Standard audio indoor station



MATERIAL	COLOUR	REF. NO.
Thermoplastic (breakproof)	ivory	SI 4 A W
high-gloss	white	SI 4 A WW
MATERIAL	COLOUR	REF. NO.
Thermoplastic (breakproof)	aluminium	SI 4 A AL
lacquered		

Measurements (W x H x D) 58 x 129 x 21.5 mm

## Standard audio indoor station Design

### A / AS RANGE



MATERIAL	COLOUR	REF. NO.
Thermoplastic (breakproof) high-gloss	ivory	SI 4 AD W
	white	SI 4 AD WW

MATERIAL	COLOUR	REF. NO.
Thermoplastic (breakproof) lacquered	aluminium	SI 4 AD AL

### Overview of the functions;

- Calling, speech, door release, light, storey call, switch/control functions and internal communication
- Reverse polarity protected 2-wire installation (J-Y(St)Y 2 x 2 x 0.8)
- Speech button with green status LED
- Freely configurable light and mute button. Function of buttons can be triggered without additional installation, e.g. for internal telephony, triggering of switching/control functions in combination with Siedle bus switching module BSM/BSE 650-..., targeted selection of door loudspeakers (outdoor stations)
- A switching function (in combination with the Siedle BSM/BSE 650-.. bus switch module) can be configured on the door release button by BPS.
- Integrated audio privacy function
- Parallel connection (simultaneous calling) of max. 4 audio modules or audio indoor stations (from the 3rd device onwards, the Siedle bus programming software (BPS) is required for programming).
- Speech connection possible at any time, even without any door call
- Connection for Siedle In-Home bus
- Connection for storey call button
- Call generator with 11 ring tone melodies, including gong
- Ring tone volume can be set at 5 levels up to 83 dB(A)
- Voice volume can be set at 5 levels
- Programming manually, plug and play and using Siedle bus programming software (BPS) according to Siedle system manual
- Indoor station with hands-free operation
- Status display for active speech connection
- Call silencing with status display
- Call differentiation between storey call, 2 door calls and internal call
- Door release/light functions at any time via the bus line
- 3 LEDs for display (e.g. door open) without additional cabling
- Display of operating status using an LED
- Visible call display with flashing LED at the speech button

### 13.2.6 Connection of standard and universal audio indoor unit

The recommended mounting height is 1.50 m. Each module is installed in a flush wall box according to DIN 49073. Installation in a deep box is recommended. Mounting is done with the enclosed support rings.

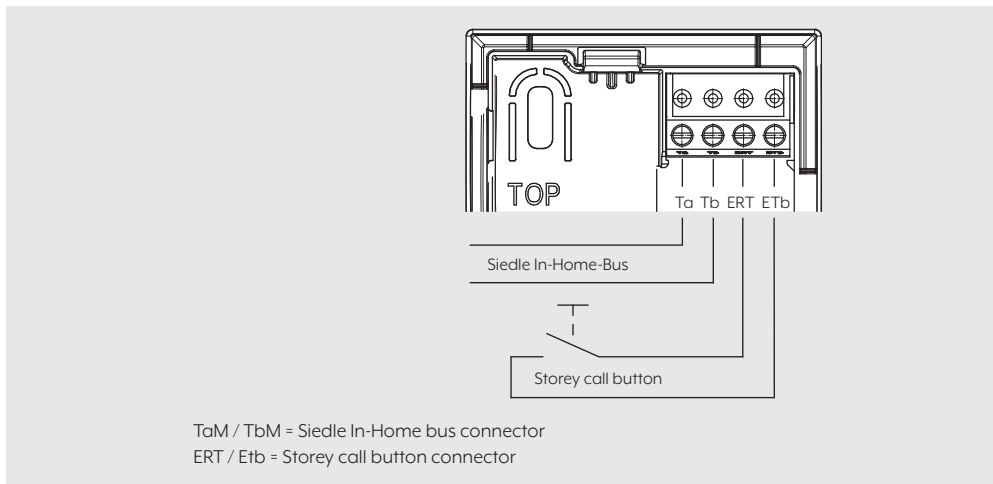

Cable type: Communication cable J-Y (St) Y with twisted pairs.

The usual diameter is 0.6 mm or 0.8 mm.

1. Remove the plug-in screw terminal.
2. Connect the cables according to the labelling (Ta Tb) on the bottom shell.
3. A storey call button must be connected between the terminals ERT and ETb.
4. The cables must be routed between the guide bars so that they are not pinched and damaged when the unit is put in place.
5. Put the screw terminal back into the provided guide.
6. Installation, commissioning and programming are described in the Siedle system manual (included with the bus power supply units BNG/BVNG 650-...).

### 13.3 Door communication and KNX

Control building system technology and building communication together for added security and comfort: The Siedle Smart Gateway and Smart Gateway Professional function as interface to the door communication in a KNX installation. The JUNG Smart Controls 7, 10, 15 and 19 and smart devices become intuitively usable video intercom stations using this.

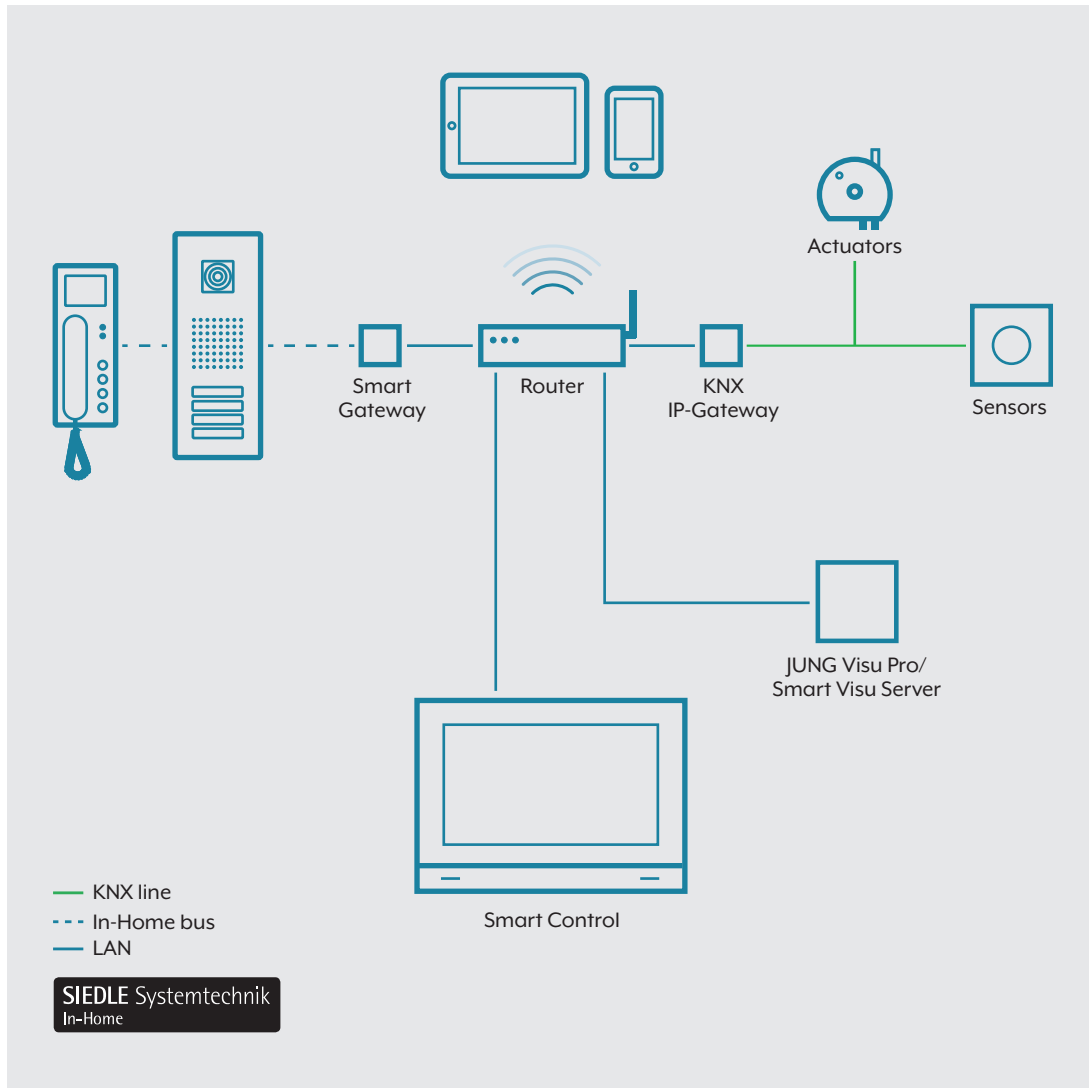

## 13.4 Oversize rocker

With JUNG you will find exactly the right system components for special installations and regulations: For example, "Open Door" push-buttons for automatic, sliding and fire doors.

The oversize rocker, also known as "elbow push-button", guarantees convenient operation and control of automatic doors: ideal for use in corridors and entrance areas. It is available in horizontal and vertical versions.

### OVERSIZE ROCKER (70 X 212.4 MM)



#### DESCRIPTION

- for switches, ref. nos.: 506 U, 507 U, 502 U, 503 U
- for push switches, ref. nos.: 506 TU, 507 TU, 502 TU
- for push-buttons, ref. nos.: 531 U, 532 U, 533 U, 533-2 U

- L** Laser engraving possible
- P** Colour printing possible

#### COLOUR

- stainless steel **L**
- white (lacquered stainless steel) **L P**

#### REF. NO.

- ES 2993
- ES 2993 WW

### OVERSIZE ROCKER (70 X 212.4 MM) WITH INDICATOR LIGHT



#### DESCRIPTION

- for control switches, ref. nos.: 506 KOU, 502 KOU, 503 KOU
- for push-button control switches, ref. nos.: 506 KOTU, 502 KOTU
- for illuminated push-buttons, ref. nos.: 531 U, 533 U, 533-2 U, 534 UU

- L** Laser engraving possible
- P** Colour printing possible

#### COLOUR

- stainless steel **L**
- white (lacquered stainless steel) **L P**

#### REF. NO.

- ES 2993 KO5
- ES 2993 KO5 WW

### OVERSIZE ROCKER (70 X 212.4 MM) WITH TEXT "OPEN DOOR" (VERTICAL MOUNTING)



#### DESCRIPTION

- for switches, ref. nos.: 506 U, 507 U, 502 U, 503 U
- for push switches, ref. nos.: 506 TU, 507 TU, 502 TU
- for push-buttons, ref. nos.: 531 U, 532 U, 533 U, 533-2 U

- L** Laser engraving possible
- P** Colour printing possible

#### COLOUR

- stainless steel **L**  
(embossed text)
- white (lacquered stainless steel) **L P**  
(embossed text)

#### REF. NO.

- ES 2993 D
- ES 2993 D WW

### OVERSIZE ROCKER (70 X 212.4 MM) WITH TEXT "OPEN DOOR" (HORIZONTAL MOUNTING)



#### DESCRIPTION

- for switches, ref. nos.: 506 U, 507 U, 502 U, 503 U
- for push switches, ref. nos.: 506 TU, 507 TU, 502 TU
- for push-buttons, ref. nos.: 531 U, 532 U, 533 U, 533-2 U

- L** Laser engraving possible
- P** Colour printing possible

#### COLOUR

- stainless steel **L**  
(embossed text)
- white (lacquered stainless steel) **L P**  
(embossed text)

#### REF. NO.

- ES 2993 DH
- ES 2993 DH WW

**OVERSIZE ROCKER (70 X 212.4 MM) WITH INDICATOR LIGHT WITH TEXT "OPEN DOOR" (VERTICAL MOUNTING)**

DESCRIPTION	COLOUR	REF. NO.
<ul style="list-style-type: none"> <li>for control switches, ref. nos.: 506 KOU, 502 KOU, 503 KOU</li> <li>for push-button control switches, ref. nos.: 506 KOTU, 502 KOTU</li> <li>for illuminated push-buttons, ref. nos.: 531 U, 533 U, 533-2 U, 534 U</li> </ul>	stainless steel <b>L</b> (embossed text)	ES 2993 KO5 D
	white (lacquered stainless steel) <b>L P</b> (embossed text)	ES 2993 KO5 D WW

**L** Laser engraving possible  
**P** Colour printing possible

**OVERSIZE ROCKER (70 X 212.4 MM) WITH INDICATOR LIGHT WITH TEXT "OPEN DOOR" (HORIZONTAL MOUNTING)**

DESCRIPTION	COLOUR	REF. NO.
<ul style="list-style-type: none"> <li>for control switches, ref. nos.: 506 KOU, 502 KOU, 503 KOU</li> <li>for push-button control switches, ref. nos.: 506 KOTU, 502 KOTU</li> <li>for illuminated push-buttons, ref. nos.: 531 U, 533 U, 533-2 U, 534 U</li> </ul>	stainless steel <b>L</b> (embossed text)	ES 2993 KO5 DH
	white (lacquered stainless steel) <b>L P</b> (embossed text)	ES 2993 KO5 DH WW

**L** Laser engraving possible  
**P** Colour printing possible

### 13.4.1 Installation special features

When installing, make sure that no plaster compensation (wallpapered over support ring) is possible, otherwise malfunctions may occur. The insert must be mounted flush on the wall. If an IP 44 installation is desired, the insert must be installed with the 551 WU sealing gasket. The IP 44 protection is only possible when using a triple frame.

### 13.4.2 Installation

#### Mounting with triple frame and optional IP 44 standard

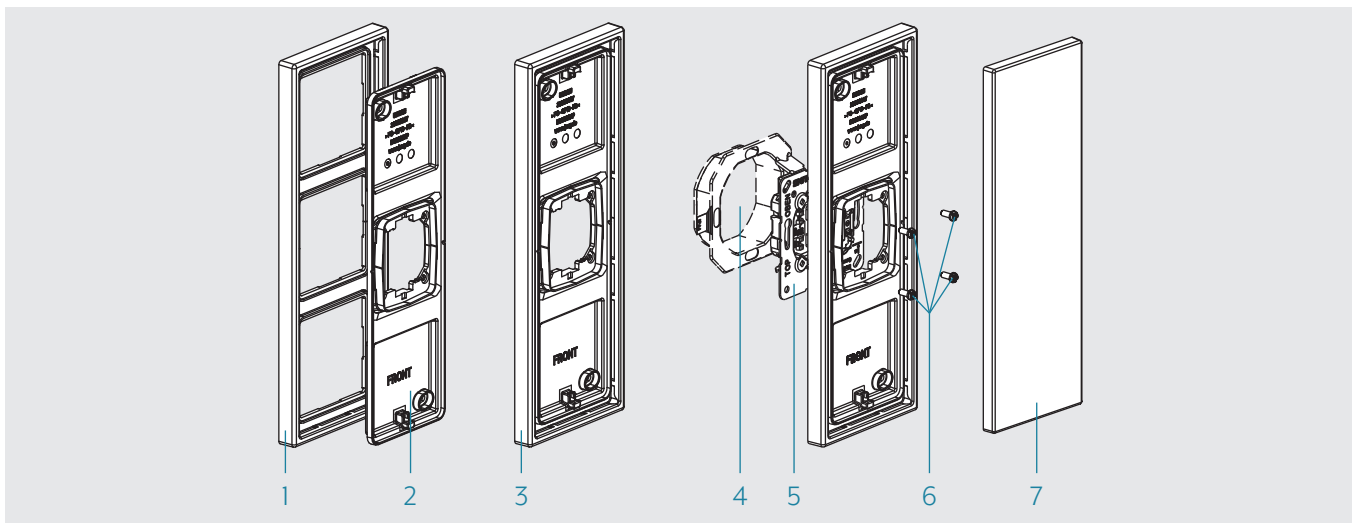

- Place the holder plate (2) on the frame (1). The holder plate clicks audibly into place.
- Optional: For IP 44 installation, attach the sealing gasket (4) under the insert (6).
- Screw the insert (5) into a wall box according to DIN 49073.
- Mount the combination of frame and holder plate (3) on the insert (5) using four screws (6).
- Place the cover (7) on the combination of frame and holder plate (3).

### Mounting with 4-gang frame according to IP 20 standard

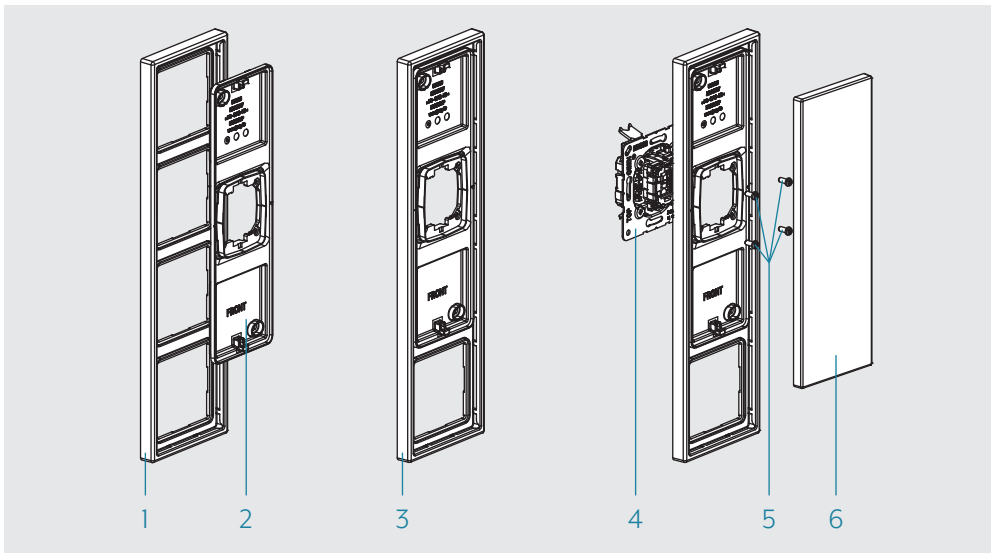

1. Click the holder plate (2) audibly onto the frame (1).
2. Mount the insert (4) into a wall box according to DIN 49073.
3. Screw the combination of frame and holder plate (3) onto the insert (4) using four screws (5).
4. Place the cover (6) on the combination of frame and holder plate (3).

### Mounting with surface-mounted housing according to IP 20 standard

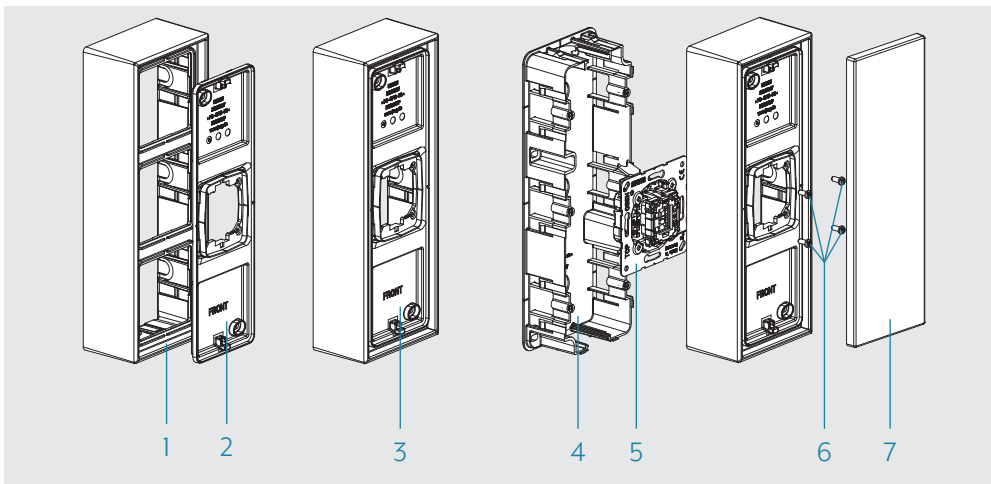

1. Click the holder plate (2) audibly onto the surface-mounted frame (1).
2. Mount the insert (5) into a 3-gang surface-mounted wall box (4).
3. Screw the combination of surface-mounted frame and holder plate (3) onto the insert (5) using 4 screws (6).
4. Place the cover (7) on the combination of surface-mounted frame and holder plate (3).





<b>14. KNX SCENARIOS</b>		<b>14.6 APPLICATION: NEW CONSTRUCTION OF A SMART HOTEL</b>	<b>284</b>
<b>14.1 SMART BUILDING TECHNOLOGY WITH KNX</b>	<b>276</b>	14.6.1 Objective of the project	285
<b>14.2 CORE KNX COMPONENTS</b>	<b>278</b>	14.6.2 Steps in the Engineering Tool software	285
<b>14.3 THE KNX-CONTROLLED HOTEL ROOM</b>	<b>280</b>	14.6.3 Additional notes	285
<b>14.4 KNX SECURE</b>	<b>281</b>	<b>14.7 JUNG VISU PRO – THE LINK</b>	<b>286</b>
<b>14.5 APPLICATION: NEW CONSTRUCTION OF A FAMILY-RUN HOTEL</b>	<b>282</b>	<b>14.8 JUNG VISU PRO – THE SYSTEM OVERVIEW</b>	<b>288</b>
14.5.1 Objective of the project	283	<b>14.9 JUNG VISU PRO – APPLICATIONS</b>	<b>290</b>
14.5.2 Steps in the Engineering Tool software	283	14.9.1 ECONOMY	290
14.5.3 Additional note	283	14.9.2 MID-SCALE	293
		14.9.3 LUXURY	295

## 14. KNX scenarios

Intelligently networked, smartly resolved: with future-proof building technology for the modern hotel. Because the guest is always entitled to expect maximum comfort. And because efficient processes and sustainability are optimally supported.

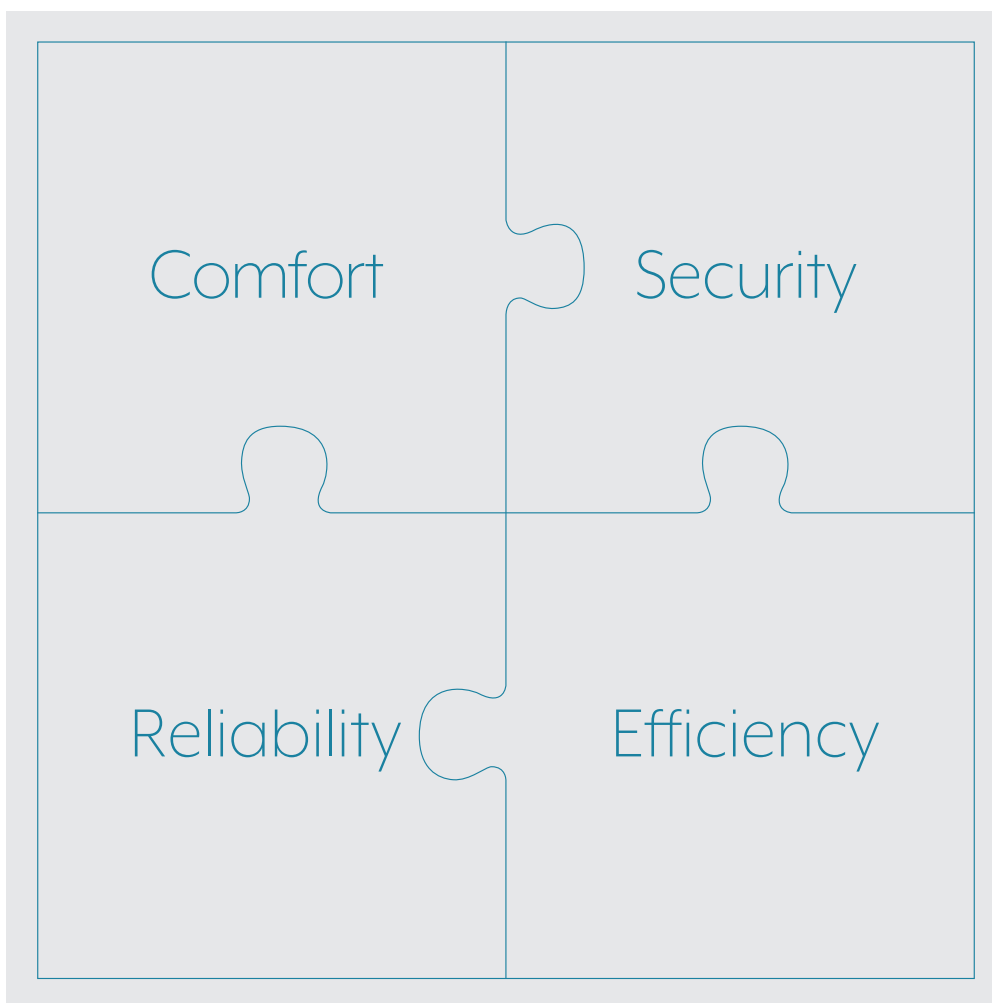

The most intelligent worldwide standard for the modern building. From the easy to use control element to the complex system, the JUNG KNX components provide comprehensive, future-proof solutions for control, visualisation and organisation of the building system technology. Areas such as lighting, shade, heating / air conditioning, surveillance / security and multimedia are completely covered here.

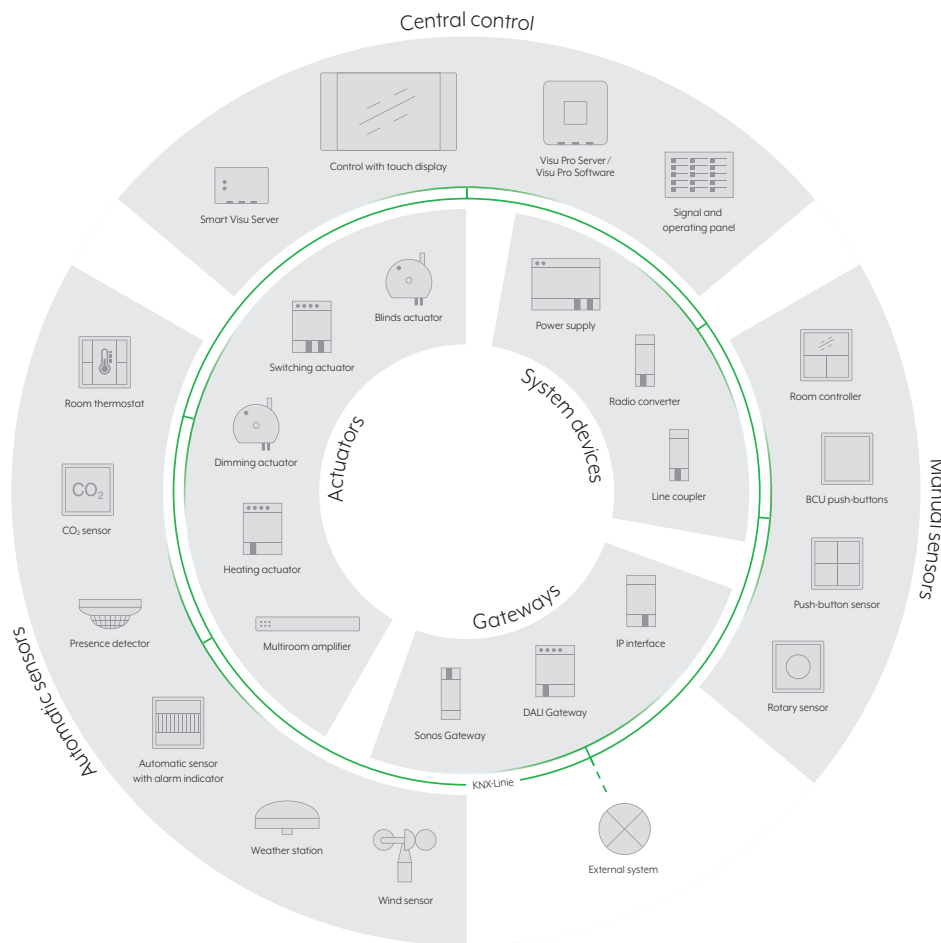

### MANUAL SENSORS

The execution of the commands and implementation of the physical states for the manual sensors are performed manually by pressing buttons or rotary movements. The information is forwarded via the KNX bus to the implementing devices.

### AUTOMATIC SENSORS

Presence detectors, weather stations or room thermostats, among other things, convert physically measured factors into electrical values, process these and send a telegram on the KNX bus for implementation of the relevant commands.

### SYSTEM DEVICES

The different KNX system devices are needed for the establishment of the bus structure (line and area couplers), as interfaces for the programming and operation of the KNX installation.

### GATEWAYS

The KNX gateways form an interface between KNX and an external network. Thereby, they translate the incoming and outgoing messages and transfer the data of the two different networks.

### ACTUATORS

Actuators receive information from the sensors, execute commands and feed back current states to the display elements of the sensors. Appropriate actuators in different designs are available in the JUNG KNX system for every application.

### CENTRAL CONTROL

The various KNX central control units form the node for networking and common control of all KNX functions, both room-related as well as for the entire building.

## 14.1 Smart building technology with KNX

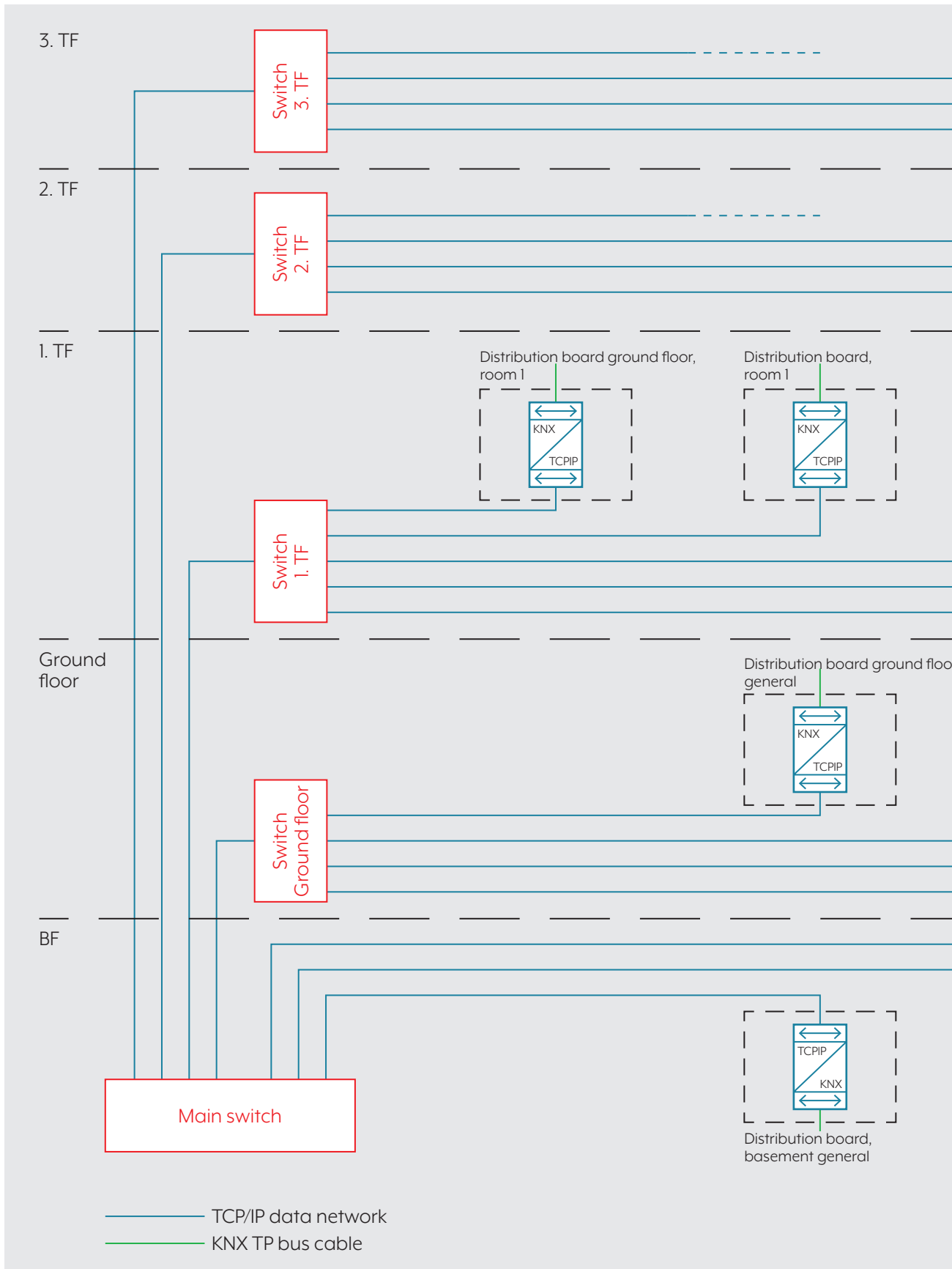

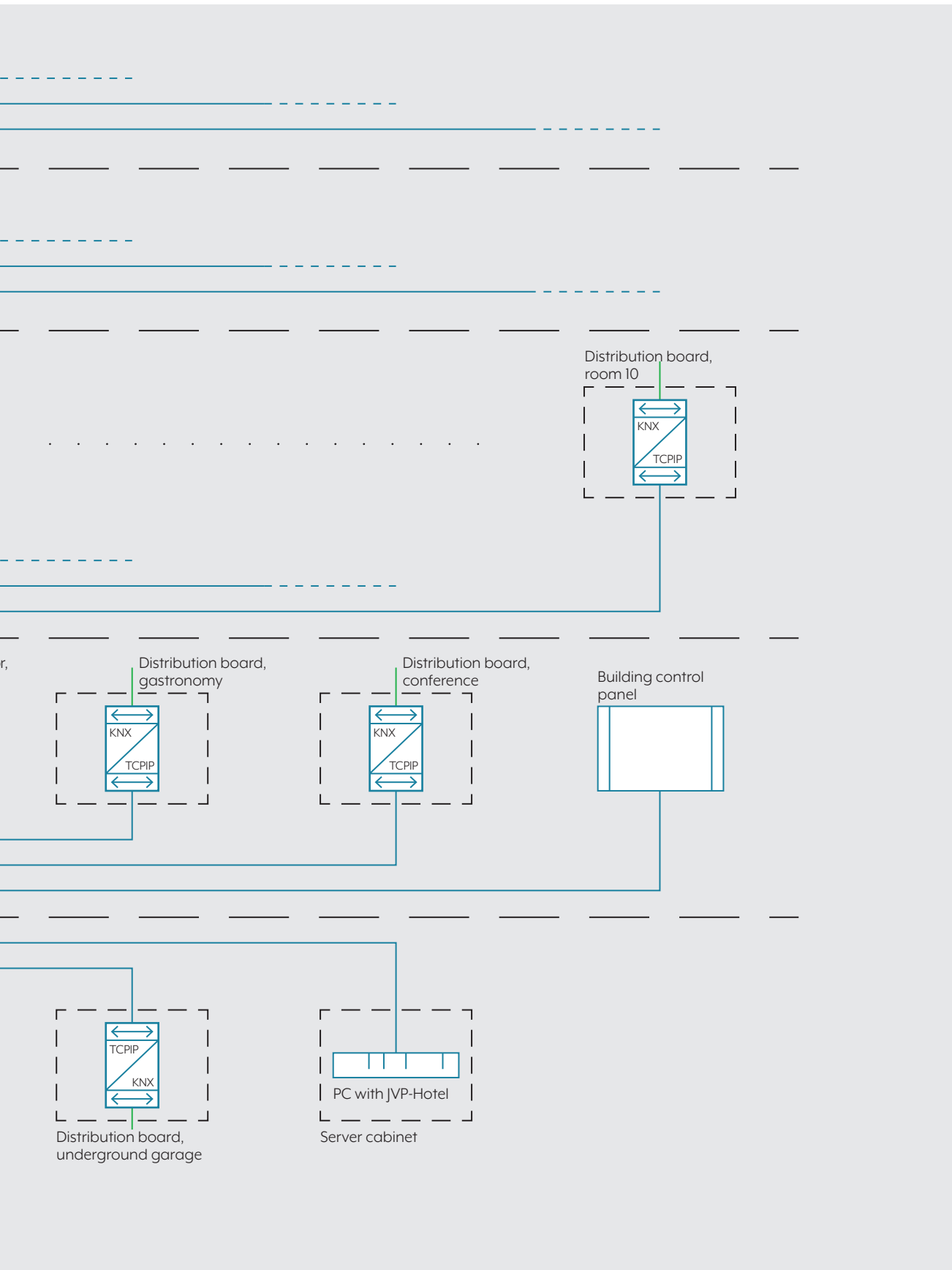

## 14.2 Core KNX components

Almost the entire building technology can be implemented and controlled with KNX.

KNX can do even more than provide comfort for the guest. With the smart KNX observers, you can detect unfavourable conditions such as leaks, temperature changes or strong wind at an early stage and minimise consequential damage.

A complete overview of all components and possible uses can be found in the JUNG KNX catalogue ([https://downloads.jung.de/catalogue/pageflip/KNX\\_de\\_2019\\_AL/](https://downloads.jung.de/catalogue/pageflip/KNX_de_2019_AL/)).

Each room has its own  
KNX power supply of 160 mA.

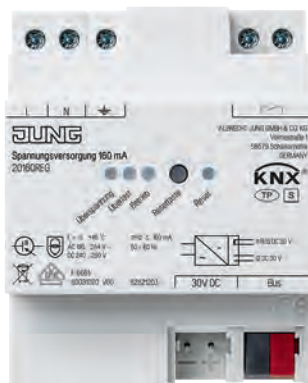

With the IP Gateway, informa-  
tion can be processed central-  
ly at the reception.



The combination unit com-  
bines power supply and IP  
interface.

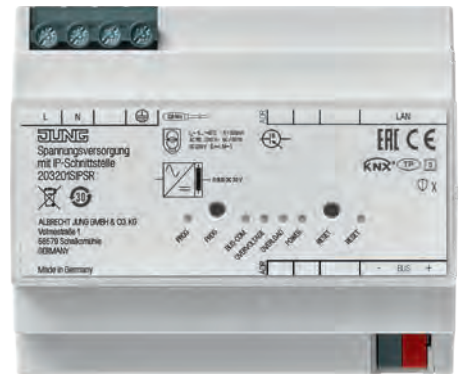

The binary interface integrates the DND / MUR system and the key card holder.



Temperature control with fan coil controller and actuator



The Multistation is the heart of the KNX installation for each room.



## 14.3 The KNX-controlled hotel room

KNX provides a wide range of options for room control. The focus is always on comfort for the guest and efficiency for the owner.

The KNX network of a luxury room is shown here as an example. Further application examples can be found on the following pages.

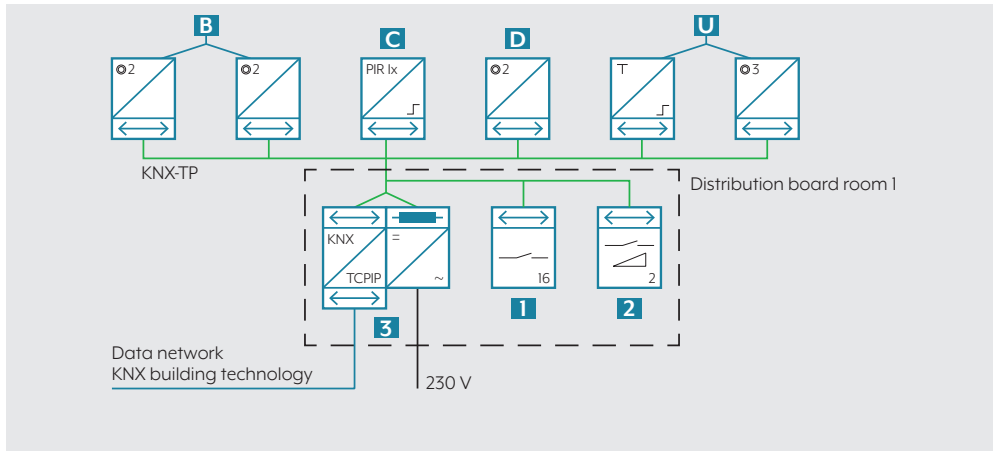

POSITION *	COMPONENTS	QUANTITY	REFERENCE NUMBER
1	Switch actuator, 16-gang	1	23016 IS R
2	Dimming actuator, 2-gang	1	3902 REGHE
3	Power supply with IP interface	1	20320 IS IPSR
B	KNX push-button F10 Universal, 2-gang	2	LS CD 10921 ST
	Rocker	2	ME 102 KO5 AT
	Frame, 2-gang	1	ME2982AT
C	Presence Detector Mini	1	3361-I MWW
D	Push-button Universal, 2-gang	1	LS CD 10921 ST
	Rocker	1	ME 102 KO5 AT
	Frame, 1-gang	1	ME 2981 AT
U	Room thermostat	1	TRDLS 9248 SW
	KNX push-button module F40 Universal, 3-gang	1	4193 TSM
	Cover kit	1	ME 2403 TSA AT
	Frame, 2-gang	1	ME 2982 AT

\* The corresponding position numbers with detailed descriptions can be found in chapter "2.1.4 Luxury B" starting from page 60.



## 14.4 KNX Secure

### **KNX IP Secure with KNX IP Interface and IP Router**

**The KNX standard stands for extra security.**

The discussion about data protection also does not stop at a building. Because everything you can operate digitally yourself, can theoretically also be controlled by unauthorised third parties. This is where JUNG KNX Secure comes in and provides effective protection thanks to encryption with the AES128 algorithm.

KNX Secure provides double protection: On the one hand, KNX IP Secure causes all telegrams to be authenticated at the network level and the transmitted data to be encrypted, regardless of the medium. Thus the communication between sensor and actuator in the IP network cannot be interpreted or manipulated. The visualisation (e.g. using the JUNG Visu Pro Server) is therefore also secure. On the other hand, KNX Data Secure also encrypts and authenticates the data on the bus line (twisted pair) and/or via wireless communication (RF). KNX Secure reliably prevents attack scenarios such as recording, replay attack or man-in-the-middle attack.

KNX IP Secure and KNX Data Secure stand for secure data transmission in KNX systems.

The KNX IP router can also be used both as an area coupler and as a line coupler.

Further information about components and possible uses can be found in the JUNG KNX Secure catalogue ([https://downloads.jung.de/catalogue/pageflip/KNX\\_Secure/](https://downloads.jung.de/catalogue/pageflip/KNX_Secure/)).

## 14.5 Application: New construction of a family-run hotel

Create professional feel-good factors for your guests with building automation. Provide your guests with the highest level of comfort with state of the art technology in the background and enable maximum energy efficiency as the owner. A central weather station allows location-based weather data to flow into the building automation system. The heating regulation is reduced with rising outdoor temperatures and thus saves money for you.

The system should be operated in a fully encrypted KNXnet / IP network so that you can always benefit from these advantages. In this way, potential hacker attacks on your building automation infrastructure can be made significantly more difficult.

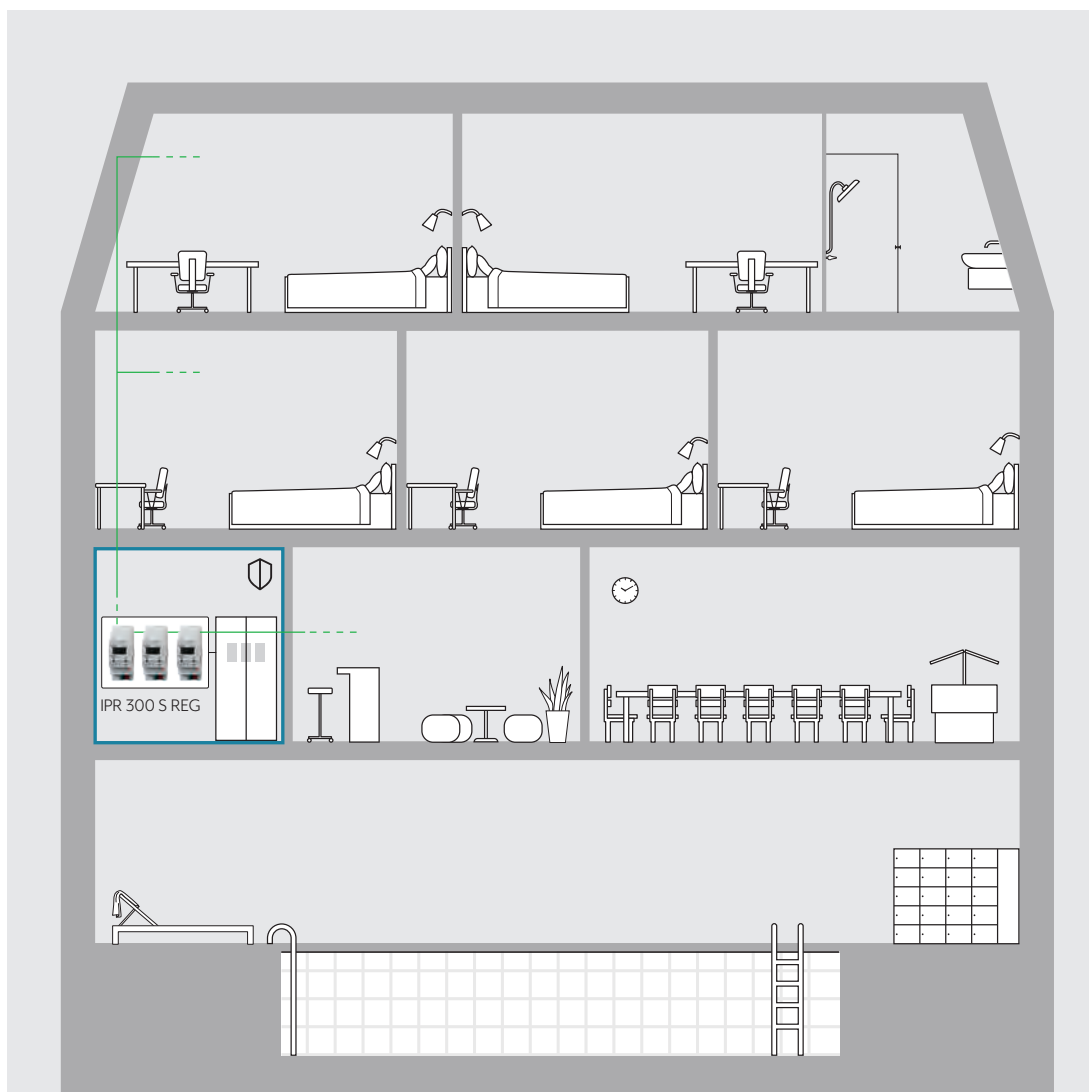

### 14.5.1 Objective of the project

- Resource and cost saving construction of a new installation
- Optimisation and automation of daily processes
- Protection of the customer data
  - Encrypted communication
  - Protection against hacker attacks
- High performance and future-proof installation

### 14.5.2 Steps in the Engineering Tool software

- Create new project and assign project password
- Add lines
  - Add IPR 300 S REG as an IP router in each case
- Use IPR 300 S REG in encrypted mode
  - Input of the device certificate
    - Change commissioning password (optional)
    - Change authentication code (optional)
  - Activate filter tables
  - Use and start up the preferred connection in the application (for visualisation communication)
  - Establish IP tunnelling for visualisation (use reserved tunnel)
- Put all other devices into operation according to the manufacturer specifications

### 14.5.3 Additional note

- Passwords are not required when the project is open.
- The commissioning password must be entered if the project is not open.

## 14.6 Application: New construction of a smart hotel

Modern hotels set new standards for individual comfort. Provide added value for your guests with building automation and relieve hotel personnel. The smart hotel can now already cover some areas perfectly. For example, the temperature in all rooms can be set or changed from a central location. A DND (Do Not Disturb) or MUR (Make Up Room) request from the guest can also be viewed at a central location. This allows you to optimally plan and execute the daily cleaning process.

As sensitive data are also transmitted in such an hotel, it is recommended to protect the data using state of the art technology. Operate a fully encrypted KNXnet / IP network for this to protect your guests and customers. The protection of customer data ensures that you as a hotel operator are also optimally protected against hacker attacks on your building automation technology.

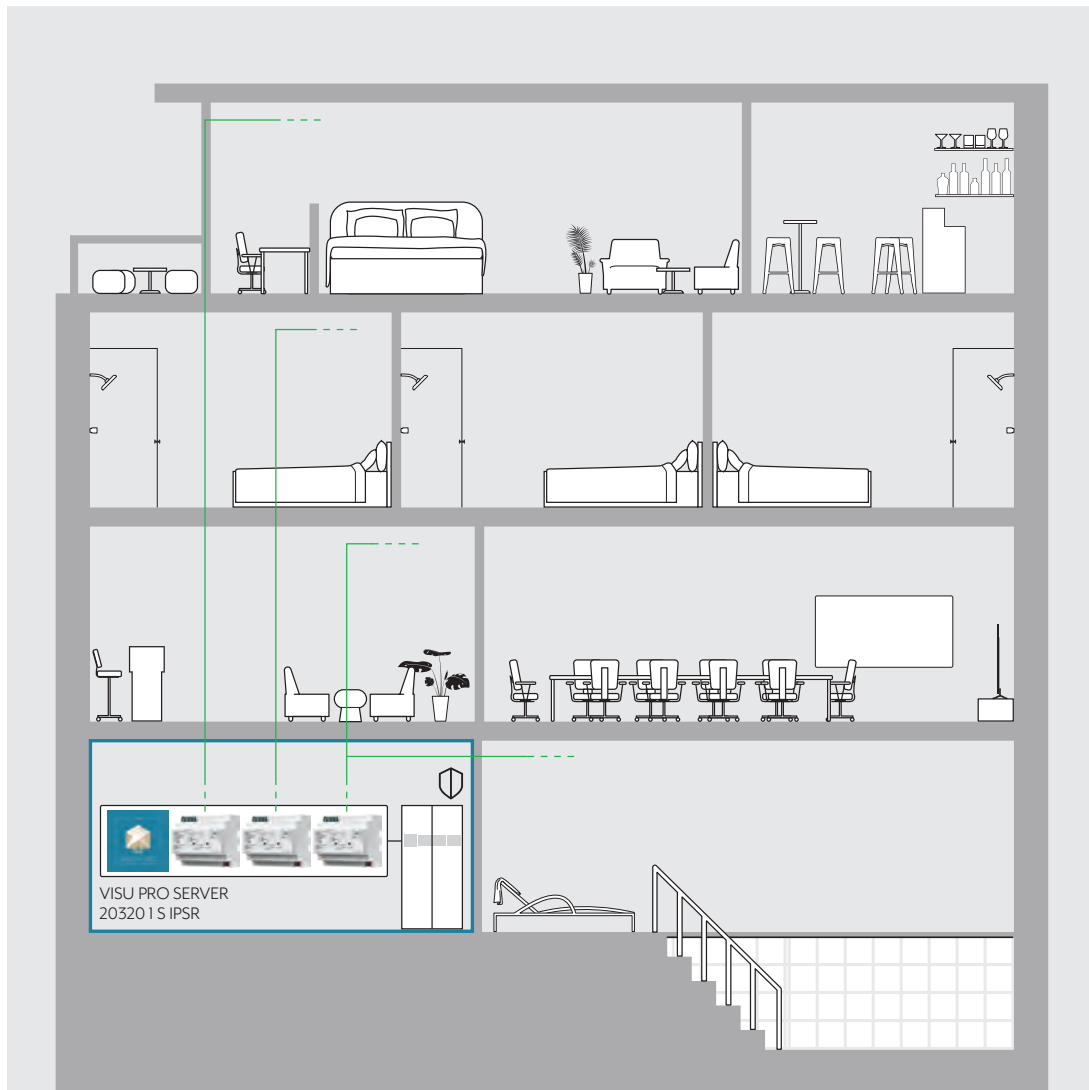

### 14.6.1 Objective of the project

- The security of guest data has the highest priority
  - Communication according to the latest security standards
- Each section is considered as its own "island"
  - Project planning can be reflected almost infinitely
- JUNG Visu Pro (JVP) Hotel manages central information of each "island" via the KNX-IP interface
- The required knowledge is minimised in the event of an error
  - Minimisation of spare devices storage
  - Replacement devices can already be pre-programmed

### 14.6.2 Steps in the Engineering Tool software

- Create new project and assign project password
- Add lines
  - Add 20320 1 S IPSR as IP interface in each case
- Use 20320 1 S IPSR in encrypted mode
  - Input of the device certificate
  - Change commissioning password (optional)
  - Change authentication code (optional)
  - Use and start up the preferred connection in the application (for visualisation communication)
  - Establish IP tunnelling for visualisation (use reserved tunnel)
- Put all other devices into operation according to the manufacturer specifications

### 14.6.3 Additional notes

- Passwords are not required when the project is open.
- The commissioning password must be entered if the project is not open.

## 14.7 JUNG Visu Pro – the link

JUNG Visu Pro is the control centre for the intelligent building. As a link between modern electrical installation and IP network, it controls all building technology components that are networked via the KNX system. As a result, it provides the possibility to integrate further technologies such as hotel management or access control into the building control system and to operate them via a uniform user interface.

The room states are clearly displayed on centrally positioned panels in the storage or personnel areas. Secure data exchange is ensured thanks to full encryption.

### SERVER AND CLIENTS

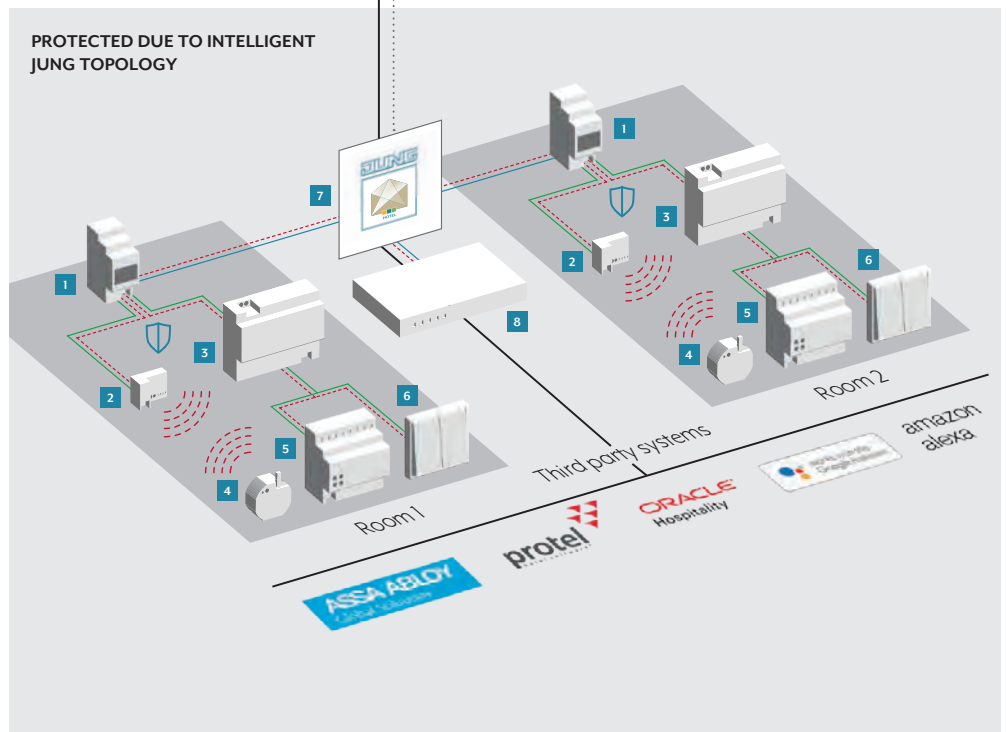
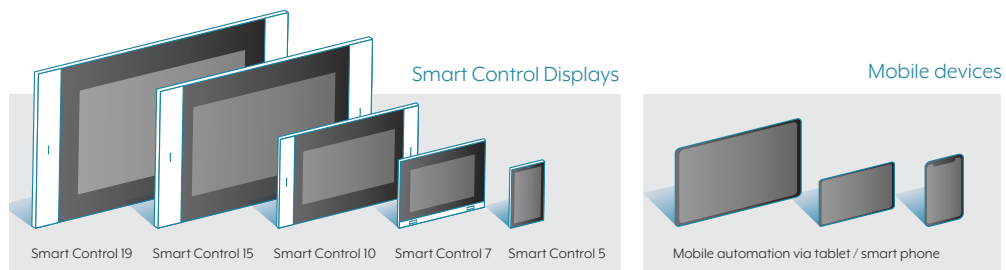

- |                                 |   |                      |                                   |
|---------------------------------|---|----------------------|-----------------------------------|
| <b>1</b> KNX System devices     | <b>5</b> KNX TP Actuator                    | <u>IP Secure</u>     | <u>IP (WLAN, https encrypted)</u> |
| <b>2</b> KNX RF Radio converter | <b>6</b> KNX TP Sensor                      | <u>KNX bus cable</u> | <u>IP (LAN, https encrypted)</u>  |
| <b>3</b> KNX Power supply       | <b>7</b> JUNG Visu Pro Server Hotel Edition | <u>Data Secure</u>   | KNX Secure                        |
| <b>4</b> KNX RF device          | <b>8</b> LAN-Router                         |                      |                                   |

### **EASY TO USE AT RECEPTION**

Personnel at the reception can view information about each room for each floor. This information includes the status of the room. In addition, the name of the guest is displayed for each room, as well as the room temperature. All data can be adjusted by the personnel with just a few clicks.

### **COMFORT (INDIVIDUAL SCENES)**

With JUNG Visu Pro, already installed scenes for building control can be started at any time. The guest can select between several scenes and choose the ones that are the most comfortable for him. Existing scenes can also be adapted to the guest's individual wishes.

### **ENERGY EFFICIENCY (SENEC)**

The SENE power storage is integrated into the customer's network via IP. Integration into the KNX system makes the energy flow in the building transparent and makes better use of electricity. SENE stands for customer-oriented solutions in the energy segment. The SENE power storage system is one of these sustainable innovations whereby intelligent infrastructures for energy system transition have been created. Therefore JUNG also relies on the competences of the energy company.

### **Display about energy self-sufficiency**

JUNG Visu Pro visualises the energy independence of the last thirty days via an energy traffic light. If the traffic light is red, there was high grid consumption. If the traffic light is yellow, grid consumption and own generation were in equilibrium. If the traffic light is green, the PV system and electricity storage system were able to cover a majority of the consumption.

### **Better use of energy**

The integration into the KNX system allows power consumers to be integrated in a practical way. As soon as enough energy is available, excess electricity (e.g. from heating elements for hot water preparation) can be used. In this way, self-generated electricity is consumed more efficiently.

### **Do something good for the environment**

By using a PV system and SENE power storage, users can reduce their CO<sub>2</sub> emissions. The Visu Pro Server provides the necessary transparency: It clearly shows how many kilograms of CO<sub>2</sub> and electricity costs have been saved by the solar installation together with the energy storage.

Thanks to the JUNG Visu Pro Server, the energy storage can be integrated into building automation. For example, it can force the SG-ready heat pump into forced operation by KNX telegram as soon as a certain amount of excess energy is available.

### **INDIVIDUALITY**

HTML5 visualisations are created consistently, thus guaranteeing the representation on different types of device. For this purpose, the control library has been significantly extended with HTML5 elements. The HTML5 controls can be freely placed on the worksheets and the look of the controls can be completely customised.

## 14.8 JUNG Visu Pro – The System Overview

JUNG VISU PRO SYSTEM OVERVIEW

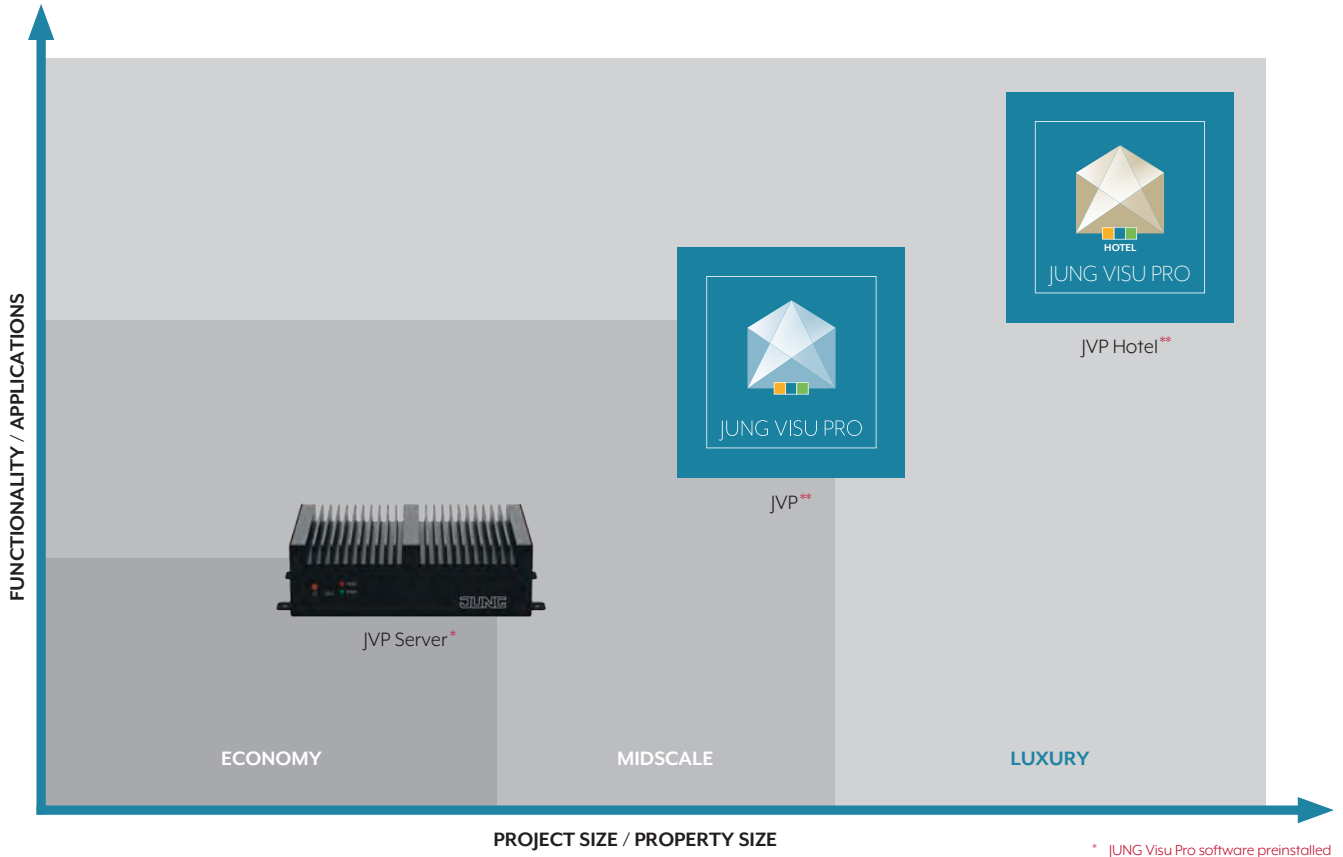

\* JUNG Visu Pro software preinstalled  
\*\* external hardware required



### **JUNG Visu Pro Server**

The JUNG Visu Pro Server is a compact device for controlling building automation with pre-installed Visu Pro software.

With its compact design, the Visu Pro Server is designed for mounting on a wall rail or on the DIN rail (enclosed adapters required). However, it can also be used as a tabletop unit. Without active fans, the Visu Pro server is completely silent in operation. The cooling is passive. The power consumption even under full load is minimal (12 W in operation, max. 6 W on standby). The built-in processors and memory enable smooth operation, even with more demanding applications

### **JUNG Visu Pro software**

The JUNG Visu Pro software is a flexible system without data point limits and is thus also perfectly suitable for complex applications in the hotel sector. Particularly the option to include multiple independent KNX systems parallel in one process model via KNXnet/IP protocol creates comprehensive possibilities for property-spanning projects. The Visu Pro software can be displayed using all HTML5-capable browsers, and of course using mobile end devices.

### **JUNG Visu Pro Hotel**

JUNG Visu Pro Hotel expands the already existing KNX Editor to up to 150 KNX tunnel connections. Communication takes place via KNX IP Secure Tunnelling. The following third party systems are also integrated in JUNG Visu Pro Hotel: Assa Abloy, Protel and Oracle. Further information about these third party systems can be found in the chapter "3.2 Software Visu Pro Hotel" on page 77.

### **Support**

If you have any questions or comments about JUNG Visu Pro, you will find a contact form on the JUNG homepage in the "Contact" section with which you can contact us. Alternatively, you can also contact the field service representative / system consultant you know. Information about our training courses in the JUNG Academy can also be found on the JUNG homepage.

## 14.9 JUNG Visu Pro – Applications

### 14.9.1 ECONOMY

- Property / Application size: Small
- Owner: MotelOne
- Excerpt of the JUNG devices used: JVP-Server-H2, IPS 300 S REG and SC7

#### Objective of the project:

- Control and adjustment of lighting in the public areas (reception, bar, corridors, etc.); set-up of visualisation in tabular form.
- Administrative pages for adjustment are password-protected.
- The lighting is controlled via the scenes (breakfast, day, evening). These are called up via a timer or twilight sensor.
- Fault messages are displayed centrally at the reception. If a fault occurs, the fault page is called up.

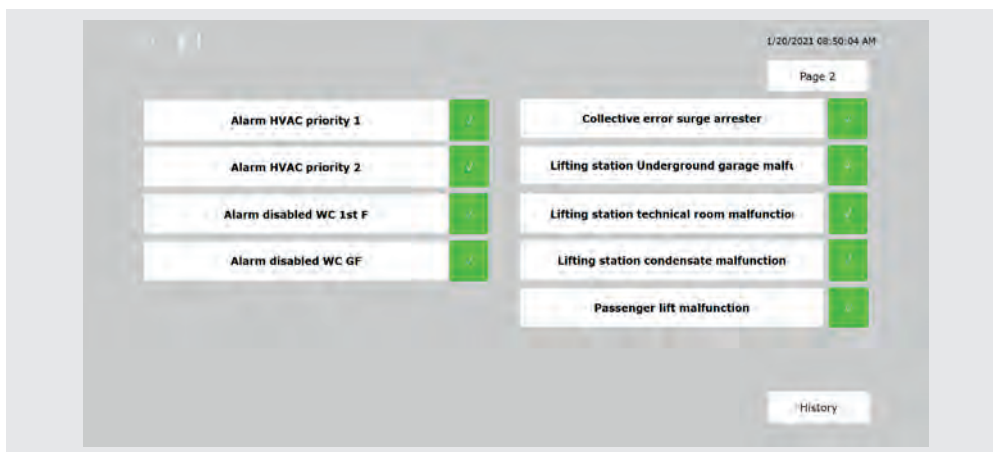
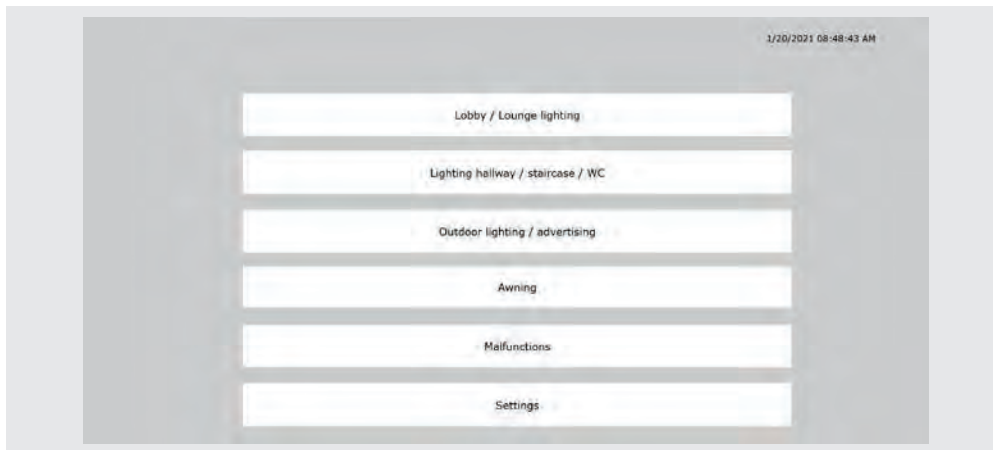

## NECESSARY COMPONENTS



**NAME**  
JUNG Visu Pro Server H2

**REF. NO.**  
JVP-Server-H2



KNX IP interface

**REF. NO.**  
IPS 300 S REG



KNX LED dimming actuator, 4-gang

**REF. NO.**  
3904REGLED



KNX Presence Detector Mini

**REF. NO.**  
3361-1 M WW



Smart Control 7

**REF. NO.**  
SC7IAL



Network switch

**REF. NO.**  
SW5REG

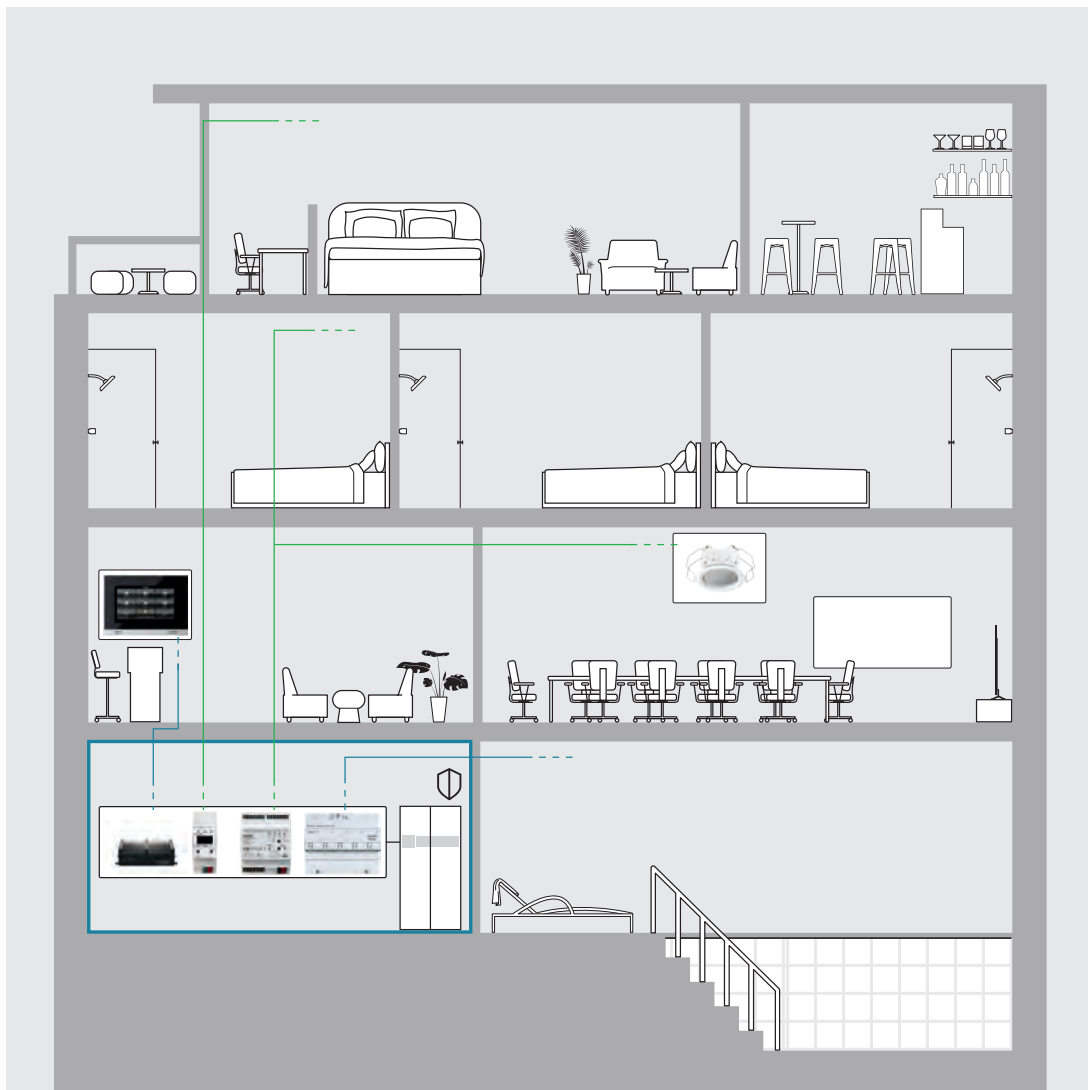

### Steps in JUNG Visu Pro

- Install KNX system according to manufacturer's specifications
- Export KNX project
- Start JUNG Visu Pro and import the project into KNX Editor 2
  - Establish connection to the KNX data interface (IPS 300 S REG)
- Create timer switches in the process module and add the desired functions of the devices.
- Start VisEditor and create optimal resolution pages for the clients
  - Use template or create individual pages
  - Protect administrative pages with a password
- Start VisServer and select project
  - Assign a start page to the control point (SC7.1)
  - Configure timer switch

### Additional note

The communication can also be set up with KNX IP Secure. This creates additional security in the network. This requires activation of the security properties of the IP interface and establishment of the encrypted connection to JUNG Visu Pro.

### 14.9.2 MID-SCALE









- Property / Application size: WeinGut Fritz Walter, D-76889 Niederhorbach, Germany. 16 new rooms, a spa area, two event rooms and a hospitality area realised with KNX.
- Owner: Eckhard Walter
- Excerpt of the JUNG devices used: JVP-Server-H2, IPR 300 S REG

#### Objective of the project:

- Control and adjustment of lighting in the public areas (reception, bar, corridors, etc.); structure of visualisation is oriented to the floor plan.
- Administrative pages for adjustment are password-protected.
- The lighting is controlled via the scenes (breakfast, day, evening). These are called up via a timer or twilight sensor.
- Fault messages are displayed centrally at the reception. If a fault occurs, the fault page is called up.
- Control of lighting and temperature only from spa area via separate PC in spa area (own pages).
- Visualisation of the floor plan of the storeys with monitoring function of the rooms. The following points are monitored:
  - Key card holders
  - Windows via window contact
  - Actual value, setpoint and heating operating mode
- Central settings of the heating in the rooms using Visu Pro.



## NECESSARY COMPONENTS

	NAME	REF. NO.
	JUNG Visu Pro Server H2	JVP-Server-H2
	KNX IP router	REF. NO. IPR 300 S REG
	KNX LED dimming actuator, 4-gang	REF. NO. 3904REGLED
	KNX Presence Detector Mini	REF. NO. 3361-1 M WW
	Smart Control 7	REF. NO. SC7I1AL
	Network switch	REF. NO. SW5REG
	Room thermostat	REF. NO. TRD..248..
	RFID key card holder + energy saving unit	REF. NO. ..CARD RFID ESU 230-2
	Push-button interface (for window contacts)	REF. NO. 2076-4 T

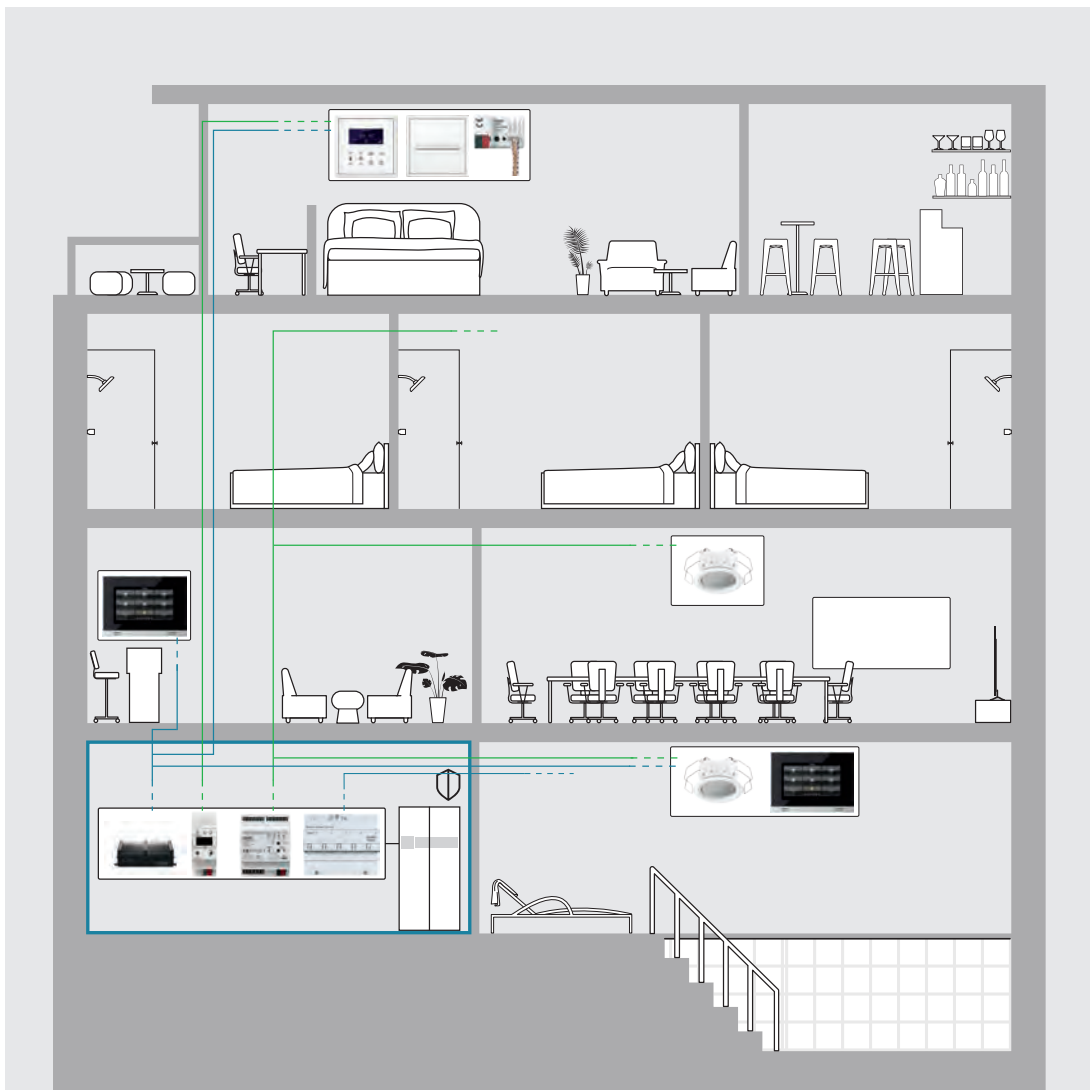

### Steps in JUNG Visu Pro

- Install KNX system according to manufacturer's specifications
- Export KNX project
- Start JUNG Visu Pro and import the project into KNX Editor 2
  - Establish connection to the KNX data interface (IPR 300 S REG)
- Create timer switches in the process module and add the desired functions of the devices.
- Start VisEditor and create optimal resolution pages for the clients
  - Use template or create individual pages
  - Protect administrative pages with a password
- Start VisServer and select project
  - Assign a start page to each control point (SC7.1)
  - Configure timer switch

### Additional note

The communication can also be set up with KNX IP Secure. This creates additional security in the network. This requires activation of the security properties of the IP router and establishment of the encrypted connection to JUNG Visu Pro.

### 14.9.3 LUXURY

- Property / Application size: SI-Suites, D-70567 Stuttgart, Germany / 192 individually designed rooms and suites
- Owner: Apartment House SI Betriebs GmbH
- Excerpt of the JUNG devices used: JVP Hotel including external hardware, Smart Control 7, Presence Detector Mini, push-button interface for window contacts

#### Objective of the project:





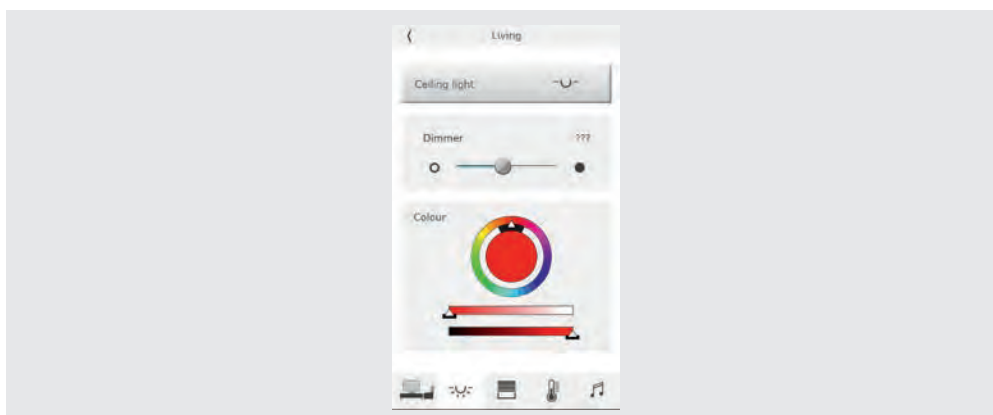





##### SI-Suites general requirements:

- Automatic shading control of the suites (outside the guest occupancy times)
  - Check-IN Guest = disabling of the suite shading,
  - Check-OUT = activation of the automatic shading control of the suite
- Room temperature
  - Check-IN Guest = ramp-up of room temperatures, various temperature profile specifications
  - Check-OUT = fixed room temperature specifications
- Light
  - Check-IN Guest = various light scenarios become active,
  - Check-OUT = Reset of the lighting situation, partially time-delayed (shut-off delay 30 minutes)
- Bluetooth  
Check-IN and Check-OUT: Clearing of the smart phone Bluetooth memory of the Bluetooth gateway is controlled by the hotel management software Protel
- General: Automatic shading control Counteraction of the room heating (summer)
- Façade closure due to window cleaning
- Suite-specific smart phone operation via app desired (one app should operate everything)
- Restaurant area: Lighting individually adjustable and can be saved
- Request: Television control (switching on and programme presetting) via KNX-JVP television control.





## NECESSARY COMPONENTS

	NAME	REF. NO.
	JUNG Visu Pro Hotel including external hardware	JVP-Hotel
	KNX IP router	REF. NO. IPR 300 S REG
	KNX LED dimming actuator, 4-gang	REF. NO. 3904REGLED
	KNX Presence Detector Mini	REF. NO. 3361-1 M WW
	Smart Control 7	REF. NO. SC7I1AL
	Network switch	REF. NO. SW 5 REG
	Room thermostat	REF. NO. TRD..248..
	RFID key card holder + energy saving unit	REF. NO. ..CARD RFID ESU 230-2
	Push-button interface (for window contacts)	REF. NO. 2076-4 T
	Bluetooth Radio	REF. NO. DAB .. BT ..

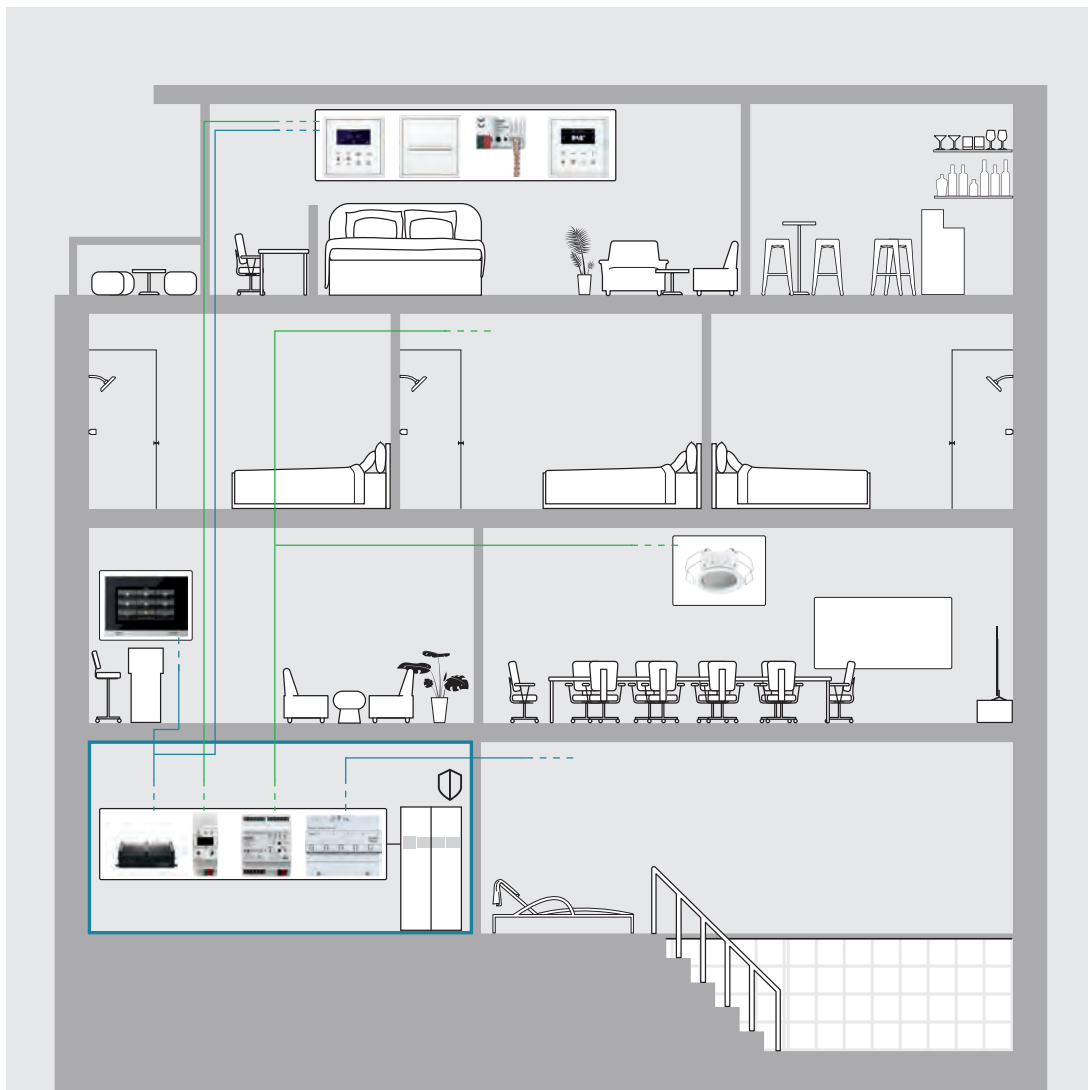

### Steps in JUNG Visu Pro

- Install KNX system according to manufacturer's specifications
- Export KNX project
- Start JUNG Visu Pro and import the project into the KNX project
  - Establish connection to the KNX data interface (IPR 300 S REG)
- Establish connection to the interface of the hotel management software (additional software required)
- Create timer switches in the process module and add the desired functions of the devices.
- Start VisEditor and create optimal resolution pages for the clients
  - Use template or create individual pages
  - Protect administrative pages with a password
- Start VisServer and select project
  - Assign a start page to each control point (SC7.1)
  - Configure timer switch

### Additional note

The communication can also be set up with KNX IP Secure. This creates additional security in the network. This requires activation of the security properties of the IP router and establishment of the encrypted connection to JUNG Visu Pro.

# Index

## Symbole

0.5 - 5 hours Continuous Off function 166  
 0.5 - 5 hours Continuous On function 166  
 I-gang adapter frame 21

## A

Access control 98, 256, 286  
 Activity colour 129  
 Air conditioning mode 220  
 Alarm operation function 167  
 All-round convenience 14, 26  
 Application examples 32, 280  
 Audio indoor station 258, 262, 263, 265, 266  
 Automatic function 178  
 Automatic Light 164  
 Automatic shading control 20, 296  
 Automatic switch 166, 168, 179, 180, 181, 182, 183, 184, 186, 192, 193, 196, 197

## B

Backlighting 106, 159  
 Basic lighting 129, 135  
 Bell function 104, 107, 110, 112  
 Brightness levels 153  
 Brightness sensor 142, 144, 145, 187, 211, 213  
 Brightness threshold 178, 181, 196  
 Building automation 282, 284, 289  
 Building communication 268  
 Building protection 226, 227  
 Building systems technology 20, 81, 241, 268, 274  
 Building technology 20, 29, 77, 79, 81, 274, 278, 286  
 Button press 25, 26, 72, 275

## C

Calibration process 192  
 Card batch 133  
 Card reader 28, 99, 107  
 Card removal 131  
 Card type 131, 133  
 Cavity wall box 21, 234  
 Ceiling observer 166, 186, 187, 188, 193, 196  
 Clever Config app 166, 185, 196  
 Colour printing 19, 253, 269, 270  
 Comfort mode 227  
 Consequential damage 278  
 Constant light regulation function 167  
 Continuous Off function 166

Continuous On function 166  
 Continuous operation 155  
 Controls 287  
 Control software 28, 77, 78  
 Convenience function 25, 167  
 Cooling 227  
 Cooling function 224  
 Corridor unit 102, 106, 107, 112, 119

## D

Day operation 181  
 Decentralised room automation 237  
 Detection field 174, 181, 184, 187, 189, 193, 194, 204, 208  
 Dimming insert 166, 167, 168, 172, 196  
 Dimming principle 172  
 Dismounting protection 114, 240, 245  
 Do not disturb 28, 102, 104, 105, 108, 109, 110, 111, 115, 116, 117, 118, 278, 284  
 Door communication 256, 258, 268  
 Door station 258

## E

Eco mode 220  
 Economy room 32, 34, 290  
 Efficient time management 78  
 Electric shaver socket outlet 23  
 Energy consumption 20, 142  
 Energy efficiency 20, 26, 28, 196, 220, 282, 287  
 Energy Management 20  
 Energy self-sufficiency 287  
 ETS product family 198  
 ETS Service app 74

## F

Façade protection 20  
 Fan coil unit 224, 225  
 Flush-mounting box 21, 87, 211, 213  
 Frost protection 226, 227  
 Furniture installation 18  
 Fused Cable Unit 87

## G

Glare protection 243  
 Glass cover 106, 138, 139  
 Goodbye function 215  
 Guest card 129, 135

**H**

Heating 227  
 Heating and cooling 28, 220  
 Heating control 282  
 Heating function 224  
 Hotel display 102  
 Hotel light / pilot light function 167  
 Hotel mode 226, 227  
 Hotel software 28, 77, 78  
 Housekeeping 14, 28, 29, 77, 104, 107, 119, 166, 167

**I**

Indicator light colour 129, 131, 133  
 Information lighting 157, 164  
 Infrastructure cabling 237  
 Installation time 14, 232, 236, 240  
 International sockets 86  
 International socket systems 21  
 IP 44 179, 180, 182, 183, 197, 206, 207, 270  
 IR remote control 193, 196, 205, 208, 209, 212, 213

**J**

JUNG Quick Charge 22, 27  
 JUNG switch design 82, 243  
 JUNG Visu Pro 281, 286, 287, 288, 289, 290, 292, 295, 298  
 JUNG Visu Pro Hotel 77, 289  
 JUNG Visu Pro software 14, 28, 29, 77, 289

**K**

Key card 98  
 Key Card Configurator 122, 130  
 Key card holder 127, 129, 131, 133, 134, 214, 216, 222, 223, 278  
 KNX automatic switch 198, 200, 202, 203, 204, 205, 206, 207, 208  
 KNX brightness controller 209, 210, 211, 212  
 KNX ceiling observer 209, 213  
 KNX-controlled 280  
 KNX Data Secure 74, 281  
 KNX IP Secure 281  
 KNX mode 226  
 KNX presence detector 198, 209, 210, 211, 213  
 KNX scenarios 274  
 KNX system 81, 119, 198, 200, 223, 275, 286, 287

**L**

Labelling 19  
 Laser engraving 19, 132, 160, 252, 253, 269, 270  
 Leading edge phase control principle 169, 172  
 Leakage 278  
 LED floodlight 157, 240, 248, 249  
 LED floor pilot light 142, 143, 144, 146  
 LED glass cover 139, 147, 158, 160  
 LED info sign 147, 148  
 LED pilot light with traffic light function 151  
 LED reading light 153  
 Lighting control 25, 166, 215  
 Lighting design 157, 240  
 Lighting request 164  
 Light socket 240, 241, 242, 243, 244, 247, 249  
 Locking time 167  
 Luxury room 32, 50, 60, 216, 217, 280, 296

**M**

Main lighting 142  
 Make up room 28, 105, 108, 109, 111, 116, 117, 118, 278, 284  
 Mechanical key card holder 124  
 Memory value 196  
 Mid-scale room 32, 42, 293  
 Minimum brightness 172, 173, 175, 217  
 Modular system 5, 168, 234, 259  
 Monitoring range 192  
 motion detection 166, 167, 194, 196

**N**

NC contact 127  
 Night light function 167  
 Night Light scene 217  
 Night mode 227  
 NO contact 104, 105, 124, 125, 127, 130, 131

**O**

Observer 166  
 Observer operating mode 166  
 Occupancy status 79  
 One-button operation 75  
 Operating controls 28  
 Operating mode 166, 169, 172, 173, 178  
 Operating options 25, 76  
 Operation modes 226  
 Orientation lighting 155, 157, 164, 240  
 Oversize rocker 269  
 Overtemperature protection 169, 172

**P**

Personnel card 129, 135  
 Pilot lamp 127  
 Pilot light 129, 138, 143, 144, 157, 167, 243  
 PIR sensor 194  
 Plastering adapter 17, 18  
 plug + go 232, 233, 234, 235, 236  
 Plug & Light 157, 240  
 Plug & Light LED Floodlights 243  
 Plug & Light LED Spotlights 243  
 Plug & Light Light Attachment 246, 248  
 Plug & Light Lighting Ranges 243  
 Power DALI 168, 175, 177  
 Presence detection 214  
 Presence detection operating mode 166  
 Presence detector 166, 174, 186, 187, 188, 193, 196, 197, 198, 227, 275, 296  
 Presence mode 217  
 Presence monitoring 216, 217  
 Protected against splash water 24  
 Pulse insert 168, 175, 178  
 Pulse operation function 167  
 Push-button function 74, 75

**R**

Radial movement 194  
 Ready to plug-in electrical installation 232  
 ready to plug-in installation modules 233  
 Real glass cover 158, 161  
 RFID key card holder 122, 129, 131, 132, 133, 135  
 Rocker function 74  
 Room air control 25  
 Room control 280  
 Room thermostats 209  
 Room Unit 102, 104, 107, 113, 114, 119  
 Rotary movement 275

**S**

Satellite unit 166, 167, 168, 171, 174, 176, 181, 187, 188  
 Savings potential 235, 237  
 SENEK 287  
 Setting parameters 196  
 Short-circuit protection 169, 172  
 Shut-off delay 130, 131, 133, 166, 167, 168, 171, 178, 181, 196, 217, 296  
 Smart building technology 276  
 Smart hotel 284  
 Sockets with USB port. 22, 27

Soft start 169, 172  
 Sources of interference 181, 184, 189, 204, 208  
 Status indicator 130, 131, 261, 263, 266  
 Status LED 185, 228, 261, 262, 263, 266  
 Step lighting 153  
 Sun protection 237  
 Surface-mounted installation 24  
 Surface mounted variant 186  
 Surface-mounted variant 12, 24  
 Switching errors 196  
 Switching state 104, 105, 158  
 Switch insert 167, 168, 169, 170, 171, 245  
 Switch-off advance warning 178  
 Switch-off advance warning function 167  
 Switch on brightness 172, 196  
 Switch-on delay 168  
 System overview 288

**T**

Tangential movement 194  
 Temperature changes 278  
 Thermal movements 166, 167  
 Timer function 82, 167  
 Traffic light function 151  
 Trailing edge phase control principle 169, 172, 245  
 Triple-tone door signal 110, 114  
 Two-button operation 75

**U**

Use case 214, 216  
 UV-resistant 24

**V**

Video indoor station 258, 259, 260, 261  
 Voltage disconnection 124

**W**

Walking test 196  
 Warm Dim 241  
 Water damage 20  
 Welcome function 215  
 Welcome scene 217  
 Welcoming light 215  
 Wireless bandwidth 82  
 WLAN Access Point 82

**Z**

Zero point circuit 168

**ALBRECHT JUNG GMBH & CO. KG**

P.O. Box 1320

58579 Schalksmühle

Germany

Phone +49 2355 806-553

Fax +49 2355 806-254

[international@jung.de](mailto:international@jung.de)

For sales contacts in your country see:

[jung-group.com/contact](http://jung-group.com/contact)

**JUNG-GROUP.COM**