

eNet radio transmitter module 1-gang

Art. no.: FM..5001M

eNet radio transmitter module 2-gang

Art. no.: FM..5002M

eNet radio transmitter module 3-gang

Art. no.: FM..5003M

eNet radio transmitter module 4-gang

Art. no.: FM..5004M

Operating instructions**1 Safety instructions**

Electrical devices may only be mounted and connected by electrically skilled persons.

Serious injuries, fire or property damage possible. Please read and follow manual fully.

The radio communication takes place via a non-exclusively available transmission path, and is therefore not suitable for safety-related applications, such as emergency stop and emergency call.

These instructions are an integral part of the product, and must remain with the end customer.

2 Battery safety instructions

This device or its accessories are supplied with batteries in the form of button cells.

DANGER! Batteries can be swallowed. This can lead directly to death by suffocation. Dangerous substances may cause severe internal burns leading to death within 2 hours.

Keep new and used batteries away from children.

Do not use devices if the battery compartment does not close securely and keep away from children.

If you suspect that a battery has been swallowed or is in any orifice of the body, seek immediate medical attention.

WARNING! Improper handling of batteries can result in explosion, fire or chemical burn due to leakage.

Do not heat or throw batteries into fire.

Do not reverse polarity, short-circuit or recharge batteries.

Do not deform or disassemble batteries.

Replace batteries only with an identical or equivalent type.

Remove empty batteries immediately and dispose of in an environmentally friendly manner.

3 Device components

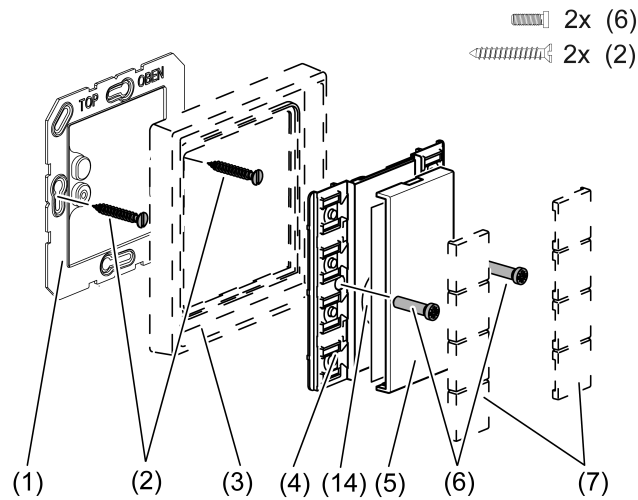

Figure 1: 4-gang radio wall transmitter module

- (1) Base plate
- (2) Fastening screws for the base plate
- (3) Design frame
- (4) Wall transmitter module
- (5) Cover
- (6) Fastening screws for the wall transmitter module
- (7) Cover kit
- (14) Battery holder

4 Function

Intended use

- Radio sensor for transmission of switching, dimming, blind movement and scene commands
- Operation with radio actuators from the eNet system

Product characteristics

- Display of the actuator status for status poll by a green status LED per channel
- Display of the transmission status by a red transmission LED
- Switch-on brightness of dimmer actuators can be saved.
- Battery-powered device
- Signalling of transmission errors can be switched off

Can be set with eNet server:

- Scene All On
- Operation locks

Supplementary function with eNet server

- Fully encrypted radio transmission (AES-CCM) from eNet Server software version 2.0
- Update of the device software

5 Operation

- i** When operating with the eNet Server, operation and signalling could vary from what is described here.

Function of LED in operation

As soon as a button is pressed or released, the transmission LED (9) signals radio transmission

- LED lights up for 2 seconds

Then, the status LED (8) signals the actuator status/group status

- LED lights up for 3 seconds:
At least one actuator is switched on, or one Venetian blind is not in the top end position
- LED remains off:
All the actuators are switched off or the blinds are all in the upper end position

i If there is no status message from an actuator, the transmission LED (9) signals a transmission error. The transmission LED flashes quickly for 5 seconds.

Channel assignment of the wall transmitter

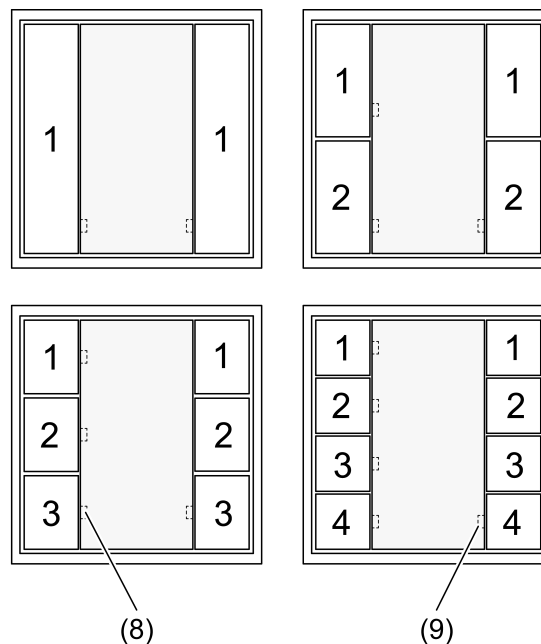

Figure 2: Channel assignment of wall transmitter module 1-gang, 2-gang, 3-gang and 4-gang

- (8) Status LED, green (one per channel)
- (9) Transmission LED, red (one per device)

Operating light

- Switching: Press button for less than 0.4 seconds.
- Dimming: Press the button for longer than 0.4 seconds. The dimming process ends when the button is released.
- Switching on dimmer actuators at minimum brightness: Press the right button for longer than 0.4 seconds.
- Switching on dimmer actuators at minimum brightness and dimming to maximum brightness: Press the left button for longer than 0.4 seconds.

Operating blind

- Moving the Venetian blind: Press the button for longer than 1 second.
- Stopping the Venetian blind or adjusting the slats: Press the button for less than 1 second.

Operating push-button actuator

- Press the left or right button of a channel: The load is switched on for the duration of the button-press.

i The maximum actuation length is 60 seconds.

Recalling scenes

- Press the scene button briefly.
Actuators switching to the saved scene.

Changing scene

- Press the scene button briefly.
Actuators switching to the saved scene.
- Setting a new scene.
- Press scene button for longer than 4 seconds.
Actuators first switching to the old scene and save the new scene after 4 seconds.

Save switch-on brightness

Precondition: The buttons of a channel are set as channel buttons.

With dimmer actuators a brightness value can be saved to which the dimmer actuator switches after a short button press.

- Set required switch-on brightness.
- Press both buttons of a channel simultaneously for longer than 4 seconds.
The light is briefly switched off and switched on again to the switch-on brightness. Switch-on brightness is saved.

Polling sum status

Precondition: The buttons of a channel are set as channel buttons.

- i** Polling is not possible with scene buttons.
- Press both buttons of channel 1 for up to 4 seconds simultaneously.
Signalling of radio transmission and group status (see function of the LED in operation)

6 Information for electrically skilled persons

Fitting the device

Precondition: To ensure good transmission quality, keep a sufficient distance from any possible sources of interference, e.g. metallic surfaces, microwave ovens, hi-fi and TV systems, ballasts or transformers.

- Change the battery (see chapter Changing the battery).
- Screw or glue the base plate (1) to an even surface. The **TOP/OBEN** label has to be at the top.
- Position the design frame (3) on the base plate.
- Screw wall transmitter module (4) to base plate.
- i** Screwing the screws too tightly could impair functions of the wall transmitter.
- Snap on the buttons (7) .

Information on gluing mounting

Precondition: To be able to fasten the wall transmitter safely, the surface must be flat and free of dust and grease.

- Remove the rear, unpunched film of the enclosed adhesive pad.
- Align the adhesive pad, stick it to the surface and smooth it out. Remove air bubbles.
- Remove the two inner segments of the front film.
- Align the base plate to the external punching and stick it on.
- i** In the case of multiple combinations, the abutting sides of the adhesive pads must be cut along the external punching using a ruler and a cutter (Figure 3).

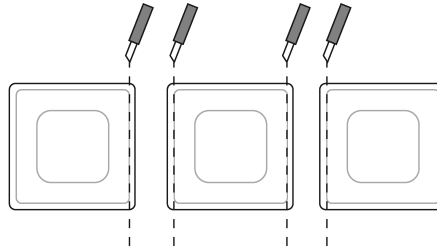

Figure 3: Cutting the adhesive pads for multiple combinations

- i** If necessary, after mounting the wall transmitter in the CD program, carefully remove the excess adhesive film in the corners.

6.1 Commissioning

Inserting the battery

- i** Obey the battery safety instructions.
- Carefully remove cover (5) from wall transmitter (Figure 1).
- Keep contacts of batteries and device free of grease.
- Apply battery to the positive contact of the battery holder (14). Observe polarity: the positive pole of the battery must be at the top.
- Press gently on battery to snap it in.
- Snap on the cover (5).



DANGER!

Mortal danger of electric shock.

During commissioning, cover the parts carrying voltage on radio transmitters and actuators and in their surrounding area.

Connecting channel button to radio actuator

- i** Up to 10 radio actuators can be connected to a transmitter in a single step.
- i** If the programming mode cannot be activated while the buttons are snapped on, they must be removed.

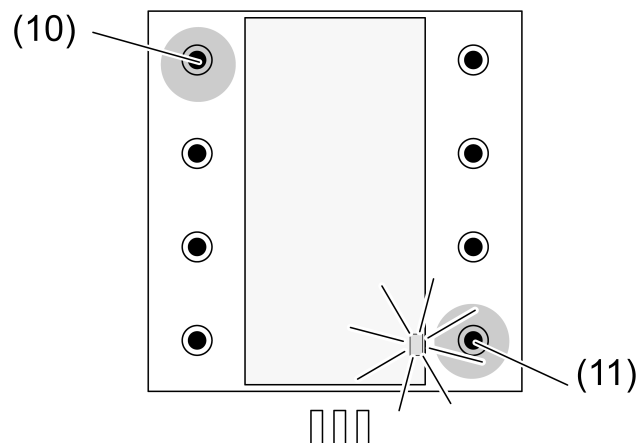

Figure 4: Activating programming mode for channel buttons

- Press the top left (10) and bottom right (11) buttons simultaneously for longer than 4 seconds (Figure 4).
The transmission LED (9) flashes slowly. The radio sensor is in programming mode for approx. 1 minute.

- Switch the actuator to programming mode (see actuator instructions).
- Press the required channel button on the left briefly.
The buttons are configured as channel buttons and connected to the actuator. The transmission LED (9) lights up for approx. 5 seconds. The radio sensor and the actuator exit the programming mode automatically.
- i** If the transmission LED (9) of the radio transmitter flashes 3 times at 1-second intervals for approx. 5 seconds, the programming operation was not successful. The actuator is outside radio range, not in programming mode or there are radio faults.
- i** If the status LED of the actuator flashes 3 times at 1-second intervals for approx. 5 seconds, then the programming operation was not successful. All the memory locations in the actuator or radio transmitter are occupied.
- i** Press the top left (10) and bottom right (11) button once again simultaneously for longer than 4 seconds to terminate the programming mode earlier.
- i** The All Off button of a radio transmitter is connected to the actuator automatically as soon as the first connection to a radio transmitter takes place. Scene buttons must be connected separately.

Connecting scene button to radio actuator

- i** If the programming mode cannot be activated while the buttons are snapped on, they must be removed.

The buttons of the wall transmitter are preallocated with the following scenes:

Release the	Button allocation
1 left / 1 right	Scene 1 / All Off
2 left / 2 right	Scenes 2 / Scene 3
3 left / 3 right	Scenes 4 / Scene 5
4 left / 4 right	Scenes 6 / Scene 7

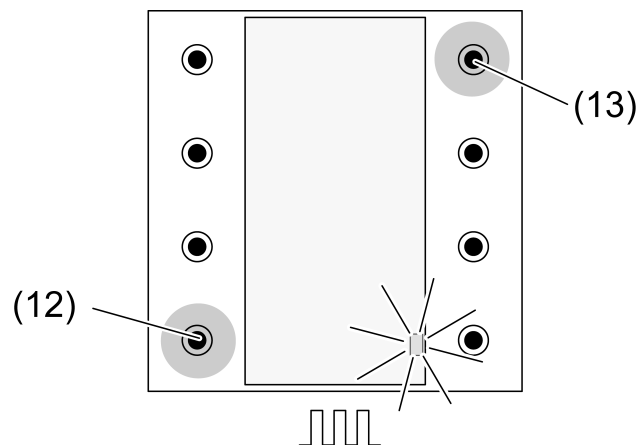

Figure 5: Activating programming mode for scene buttons

- Press the top right (13) and bottom left (12) buttons simultaneously for 4 seconds (Figure 5).
The transmission LED (9) flashes slowly. The radio sensor is in programming mode for approx. 1 minute.
- Switch radio actuator to programming mode (see radio actuator instructions).
- Press the scene button briefly.
The button is configured as scene button and connected to the actuator. The transmission LED (9) lights up for approx. 5 seconds. The programming mode is exited automatically.

- i** If the transmission LED (9) on the radio transmitter flashes 3 times at 1-second intervals for approx. 5 seconds, the programming operation was not successful. The actuator is outside radio range, not in programming mode or there are radio faults.
- i** If the status LED of the actuator flashes 3 times at 1-second intervals for approx. 3 seconds, the programming operation was not successful because all memory locations in the actuator or radio transmitter are occupied.
- i** Press the top right (13) and bottom left (12) button once again simultaneously for longer than 4 seconds to terminate the programming mode earlier.

Disconnecting connection to an actuator

- Carry out the same steps as when connecting (see the chapter Connecting channel button to radio actuator or scene button to radio actuator).
The status LED of the actuator flashes quickly for 5 seconds. The actuator is disconnected from the radio transmitter. The actuator and radio transmitter exit the programming mode automatically.
- i** If there several connections or scene buttons for an actuator, all the connections must be disconnected individually.
- i** All On and All Off buttons of a radio transmitter are disconnected automatically as soon as the last connection to the actuator is disconnected. Manual disconnection is not possible.

Polling button programming

- Briefly press the top right (13) and bottom left (12) buttons simultaneously (Figure 5).
All functions are terminated.
Permanent lighting of the status LED (8) for programming as channel button.
Rapid flashing of the status LED (8) for programming as scene button.

Resetting the channel or scene button

The connections to the actuators are disconnected and parameters are reset to default setting.

- i** The connections in the actuators are preserved and must be deleted separately.
- Press the top left (10) and bottom right (11) buttons simultaneously for longer than 20 seconds (Figure 4).
After 4 seconds, the transmission LED (9) flashes. After 20 seconds, the transmission LED flashes faster.
- Press the desired button briefly.
The transmission LED flashes more slowly.
The channel button or scene button has been reset. The setting as channel button or scene button is retained.

Resetting wall transmitter to the default setting

The connections to the actuators are disconnected and parameters are reset to default setting.

- i** The connections in the actuators are preserved and must be deleted separately.
- Press the top left (10) and bottom right (11) buttons simultaneously for longer than 20 seconds (Figure 4).
After 4 seconds, the transmission LED (9) flashes. After 20 seconds, the transmission LED flashes faster.
- Release buttons and press the top left (10) and bottom right (11) buttons simultaneously once again.
The transmission LED flashes more slowly for approx. 5 seconds.
The wall transmitter is reset to default setting. All the buttons are set as channel buttons.

7 Disposal of batteries



Remove empty batteries immediately and dispose of in an environmentally friendly manner. Do not throw batteries into household waste. Consult your local authorities about environmentally friendly disposal. According to statutory provisions, the end consumer is obligated to return used batteries.

8 Technical data

Rated voltage	DC 3 V
Battery type	1×Lithium CR 2450N
Ambient temperature	-5 ... +45 °C
Degree of protection	IP20
Protection class	III
Transmitting range in free field	typ. 100 m
Radio frequency	868.0 ... 868.6 MHz
Transmission capacity	max. 20 mW
Receiver category	2

9 Parameter list

The device parameters can be changed with the eNet server:

Device configuration

Parameter name	Setting options, Basic setting	Explanations
Function	Rocker, Other modes, Unused Basic setting: Rocker	<p>Rocker The channel works as a channel button. Setting is always made in pairs.</p> <p>Other modes The channel works as a scene button. Setting is always made in pairs.</p> <p>Unused The channel is not displayed in the eNet SMART HOME app and is disabled for use in the commissioning interface.</p>

Parameter name	Setting options, Basic setting	Explanations
Operating mode	App use, lock-out protection, forced operation, wind alarm, sun protection, twilight Basic setting: App use	Setting the type of scene used for a scene button. Setting is always made in pairs.

Advanced settings

Parameter name	Setting options, Basic setting	Explanations
Manual commissioning	On, Off Basic setting: On	Disables manual commissioning for all device channels. Note: In the "Off" setting, the device cannot be reset to the factory setting.

Extended channel settings

Parameter name	Setting options, Basic setting	Explanations
Manual commissioning	On, Off Basic setting: On	Blocks manual commissioning for the device channel. Note: In the "Off" setting, the device cannot be reset to the factory setting.
Local Operation	On, Off Basic setting: On	Blocks the device channel for local operation.

10 Troubleshooting

After a brief button-press, the transmission LED flashes.

Cause: battery in the wall transmitter is almost empty.
Change the battery (see chapter Insert battery).

Receiver does not react, transmission LED displays a transmission error. The transmission LED flashes quickly for approx. 3 seconds.

Cause 1: Radio range exceeded. Structural obstacles reduce the range.
Using a radio repeater.

Cause 2: Actuator is not ready for operation.
Check the actuator and mains voltage.

Cause 3: There are radio faults, e.g. through outside radio.
Eliminate radio interference.

i The actuator causing the transmission error can be removed from the display of transmission errors. To do this, briefly press the top left (10) and bottom right (11) buttons of the wall transmitter simultaneously during the signalling. The transmission LED lights up. During this time, do not press any button on the wall transmitter. The actuator is automatically taken into account again when it transmits a status message after radio transmission.

After a button has been pressed, the status LED flashes red quickly for 3 seconds.

Cause: Maximum permitted transmission period (statutory Duty Cycle Limit) has almost been reached. For the function of the transmitter to continue, the polling and display of the sum status will be switched off. As soon as sufficient transmission time is available again, the sum status will again be polled on button actuation.

- Actuate the transmitter again after a short waiting time, normally a few seconds.
- Reduce the number of actuations.
- Reduce the number of actuators connected to the transmitter.

11 Accessories

Cover kit 1-gang	Art. no. ..501 TSA..
Cover kit 2-gang	Art. no. ..502 TSA..
Cover kit 3-gang	Art. no. ..503 TSA..
Cover kit 4-gang	Art. no. ..504 TSA..

12 Conformity

Hereby Albrecht Jung GmbH & Co. KG declares that the radio system type Art.-no. FM..5001M / FM..5002M / FM..5003M / FM..5004M corresponds to the directive 2014/53/EU. You can find the full article number on the device. The complete text of the EU Declaration of Conformity is available under the Internet address: www.jung.de/ce

13 Warranty

The warranty is provided in accordance with statutory requirements via the specialist trade.

ALBRECHT JUNG GMBH & CO. KG

Volmestraße 1
58579 Schalksmühle
GERMANY

Telefon: +49 2355 806-0
Telefax: +49 2355 806-204
kundencenter@jung.de
www.jung.de